

### Product Summary

$V_{(BR)DSS}$	$R_{DS(on)MAX}$	$I_D$
60V	2.5Ω@10V	0.3A
	3Ω@4.5V	

### Feature

- Trench Power MV MOSFET technology
- Voltage controlled small signal switch
- Low input Capacitance
- Fast Switching Speed
- Low Input / Output Leakage

### Application

- Battery operated systems
- Solid-state relays
- Direct logic-level interface:TTL/CMOS

### Package

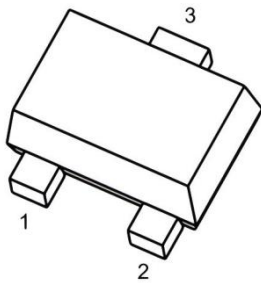

SOT-723

### Circuit diagram

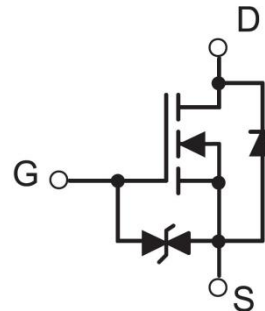

### Marking

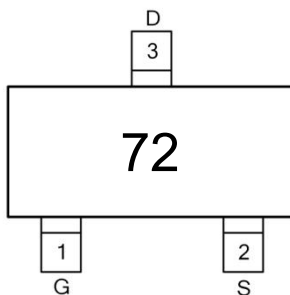

### Absolute maximum ratings ( $T_A=25^\circ\text{C}$ unless otherwise noted)

Parameter	Symbol	Value	Unit
Drain-Source Voltage	$V_{DS}$	60	V
Gate-Source Voltage	$V_{GS}$	$\pm 20$	V
Continuous Drain Current	$I_D$	0.3	A
Continuous Drain Current ( $T_A=100^\circ\text{C}$ )	$I_D(100^\circ\text{C})$	0.2	A
Pulsed Drain Current <sup>1)</sup>	$I_{DM}$	0.9	A
Power Dissipation <sup>2)</sup>	$P_D$	0.34	W
Thermal Resistance from Junction to Ambient <sup>3)</sup>	$R_{\theta JA}$	360	$^\circ\text{C}/\text{W}$
Operating Junction Temperature	$T_J$	-55 ~ +150	$^\circ\text{C}$
Storage Temperature Range	$T_{STG}$	-55 ~ +150	$^\circ\text{C}$

### Electrical characteristics ( $T_J=25^\circ\text{C}$ , unless otherwise noted)

Parameter	Symbol	Test Condition	Min.	Typ.	Max.	Unit
<b>Static Characteristics</b>						
Drain-source breakdown voltage	$V_{(BR)DSS}$	$V_{GS}=0\text{V}, I_D=250\mu\text{A}$	60			V
Zero gate voltage drain current	$I_{DSS}$	$V_{DS}=60\text{V}, V_{GS}=0\text{V}$			1	$\mu\text{A}$
Gate-body leakage current	$I_{GSS}$	$V_{GS}=\pm 20\text{V}, V_{DS}=0\text{V}$			$\pm 10$	$\mu\text{A}$
Gate threshold voltage	$V_{GS(th)}$	$V_{DS}=V_{GS}, I_D=250\mu\text{A}$	1	1.5	2.5	V
Drain-source on-resistance	$R_{DS(on)}$	$V_{GS}=10\text{V}, I_D=0.3\text{A}$		1.8	2.5	$\Omega$
		$V_{GS}=4.5\text{V}, I_D=0.2\text{A}$		2	3	
<b>Dynamic characteristics<sup>4)</sup></b>						
Input Capacitance	$C_{iss}$	$V_{DS}=30\text{V}, V_{GS}=0\text{V}, f=1\text{MHz}$		13		pF
Output Capacitance	$C_{oss}$			5		
Reverse Transfer Capacitance	$C_{rss}$			1		
Total Gate Charge	$Q_g$	$V_{DS}=30\text{V}, V_{GS}=10\text{V}, I_D=0.3\text{A}$		1.22		nC
Gate-Source Charge	$Q_{gs}$			0.5		
Gate-Drain Charge	$Q_{gd}$			0.18		
Turn-on delay time	$t_{d(on)}$	$V_{DS}=30\text{V}, V_{GS}=10\text{V}, I_D=0.3\text{A}$ $R_{GEN}=50\Omega$		7		nS
Turn-on rise time	$t_r$			19		
Turn-off delay time	$t_{d(off)}$			20		
Turn-off fall time	$t_f$			84		
<b>Source-Drain Diode characteristics</b>						
Diode Forward Current	$I_S$				0.3	A
Diode Forward voltage	$V_{SD}$	$V_{GS}=0\text{V}, I_S=0.3\text{A}$			1.2	V
Reverse Recovery Time	$T_{rr}$	$I_F=0.3\text{A}, di/dt=-100\text{A}/\mu\text{s}$		16		nS
Reverse Recovery Charge	$Q_{rr}$				3.6	

Notes:

- 1) Repetitive rating; pulse width limited by max. junction temperature.
- 2)  $P_D$  is based on max. junction temperature, using junction-case thermal resistance.
- 3) The value of  $R_{\theta JA}$  is measured with the device mounted on 1 in<sup>2</sup> FR-4 board with 2oz. Copper, in the still air environment with  $T_A=25^\circ\text{C}$ . The maximum allowed junction temperature of 150 $^\circ\text{C}$ . The value in any given application depends on the user's specific board design.
- 4) Guaranteed by design, not subject to production testing.

## Typical Characteristics

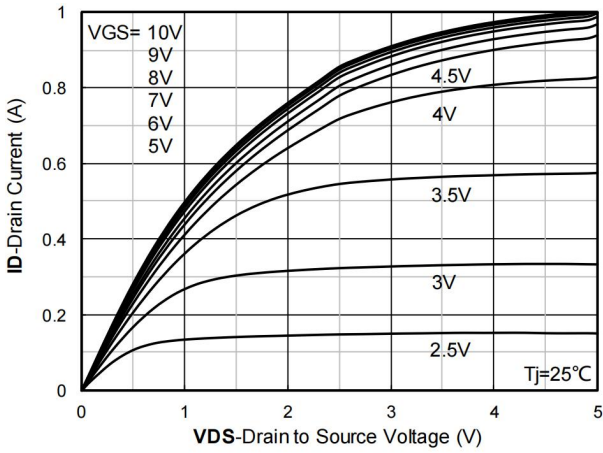

Figure 1. Output Characteristics

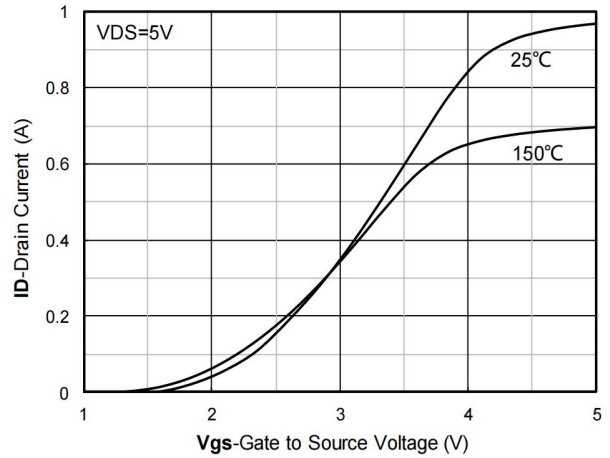

Figure 2. Transfer Characteristics

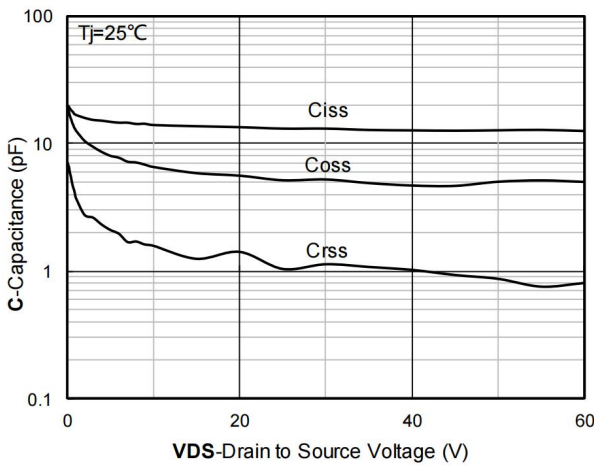

Figure 3. Capacitance Characteristics

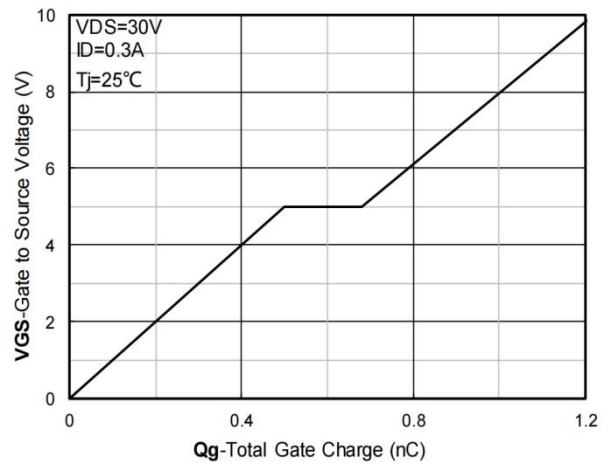

Figure 4. Gate Charge

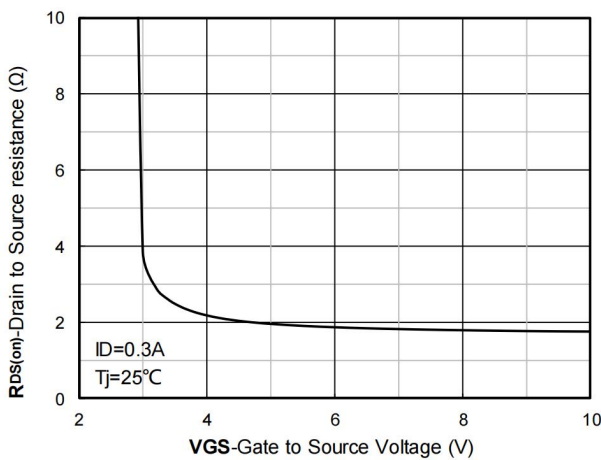

Figure 5. On-Resistance vs Gate to Source Voltage

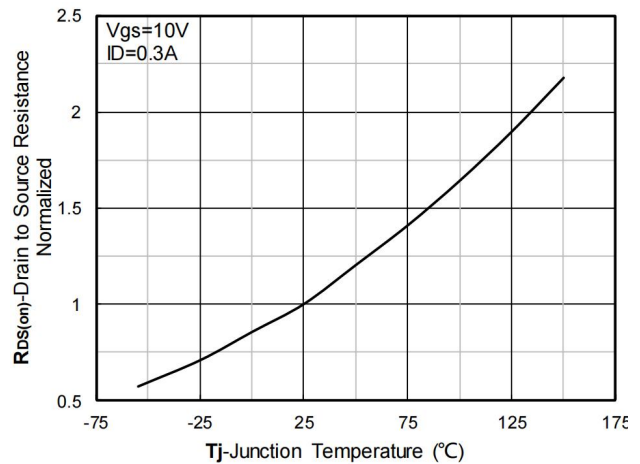

Figure 6. Normalized On-Resistance

## Typical Characteristics

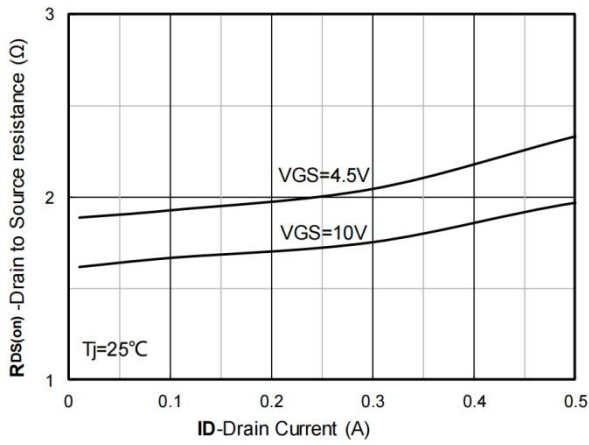

Figure 7. RDS(on) VS Drain Current

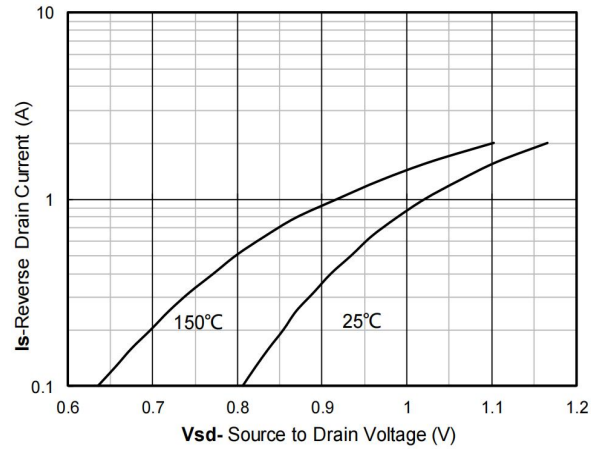

Figure 8. Forward characteristics of reverse diode

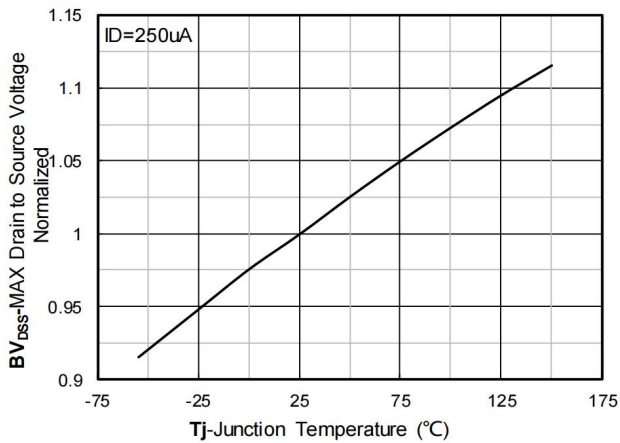

Figure 9. Normalized breakdown voltage

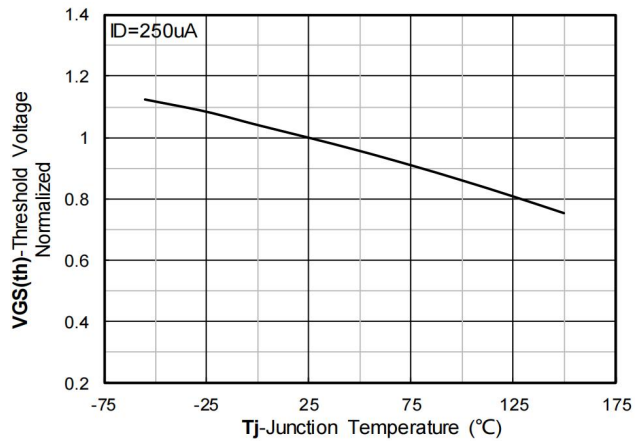

Figure 10. Normalized Threshold voltage

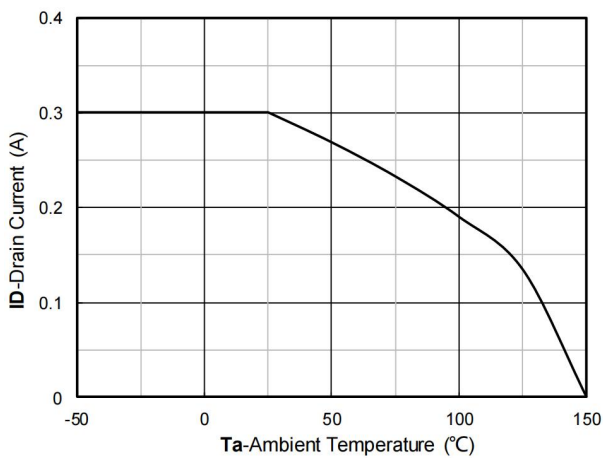

Figure 11. Current dissipation

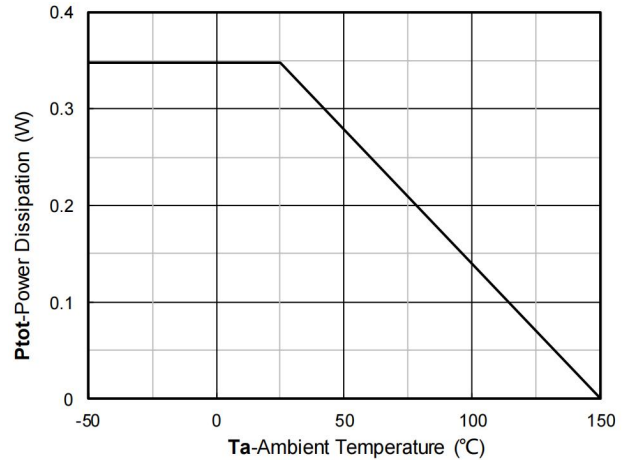

Figure 12. Power dissipation

## Typical Characteristics

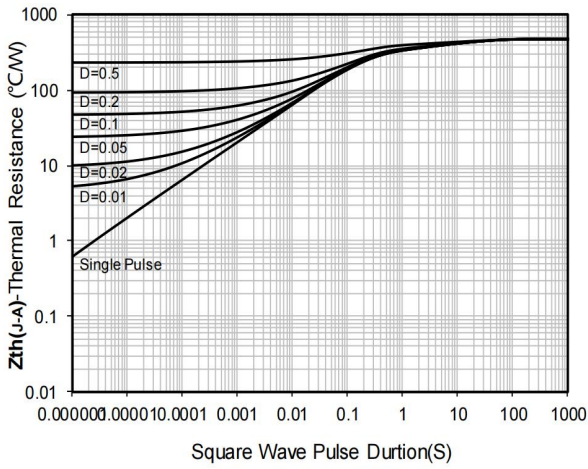

Figure 13. Maximum Transient Thermal Impedance

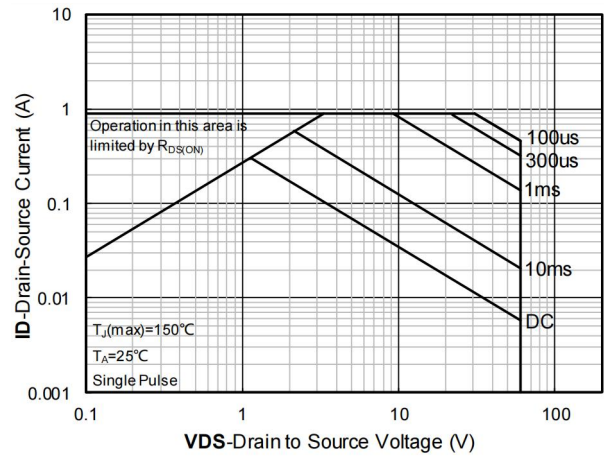
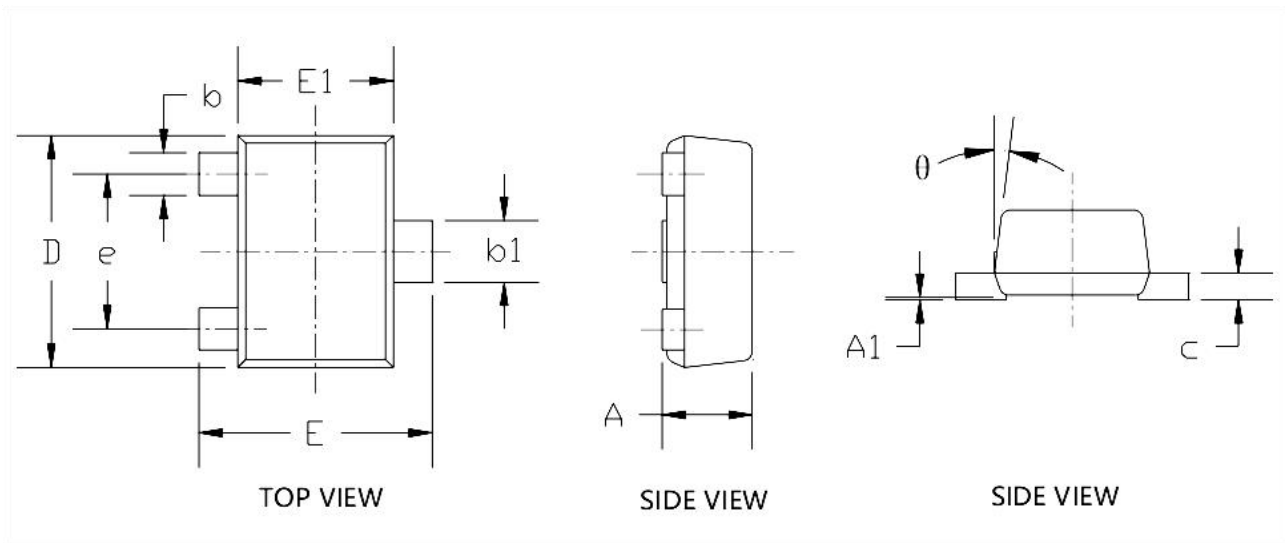

Figure 14. Safe Operation Area

### SOT-723 Package Information



Symbol	Dimensions In Millimeters		Dimensions In Inches	
	Min.	Max.	Min.	Max.
A	0.430	0.550	0.017	0.022
A1	0.000	0.050	0.000	0.002
b	0.170	0.270	0.007	0.011
b1	0.270	0.370	0.011	0.015
c	0.080	0.200	0.003	0.008
D	1.150	1.250	0.045	0.049
E	1.150	1.250	0.045	0.049
E1	0.750	0.850	0.030	0.033
e	0.800 TYP.		0.031 TYP.	
$\theta$	7° REF.		7° REF.	