

Product Summary

$V_{(BR)DSS}$	$R_{DS(on)MAX}$	I_D
60V	2.5mΩ@10V	140A
	3.5mΩ@4.5V	

Feature

- Split gate trench MOSFET technology
- Excellent package for heat dissipation
- High density cell design for low $R_{DS(ON)}$

Application

- DC-DC converter
- Power switching application
- Uninterruptible power supply

Package

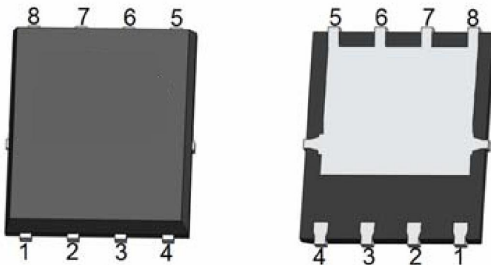

PDFN5*6-8L

Circuit diagram

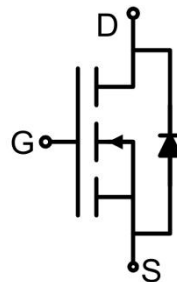

Marking

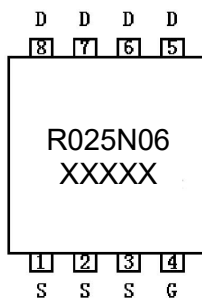

Absolute maximum ratings (T_A=25°C unless otherwise noted)

Parameter	Symbol	Value	Unit
Drain-Source Voltage	V _{DS}	60	V
Gate-Source Voltage	V _{GS}	±20	V
Continuous Drain Current(T _C =25°C)	I _D	140	A
Continuous Drain Current(T _C =100°C)	I _D (100°C)	88	A
Pulsed Drain Current ¹⁾	I _{DM}	560	A
Power Dissipation(T _C =25°C) ³⁾	P _D	113	W
Thermal Resistance,Junction-to-Ambient ⁴⁾	R _{θJA}	50	°C/W
Thermal Resistance,Junction-to-Case	R _{θJC}	1.1	°C/W
Single pulse avalanche energy ²⁾	E _{AS}	800	mJ
Junction Temperature	T _J	150	°C
Storage Temperature	T _{STG}	-55 ~ +150	°C

Electrical characteristics (T_J=25 °C, unless otherwise noted)

Parameter	Symbol	Test Condition	Min.	Typ.	Max.	Unit
Static Characteristics						
Drain-source breakdown voltage	V _{(BR)DSS}	V _{GS} = 0V, I _D =250μA	60			V
Zero gate voltage drain current	I _{DSS}	V _{DS} =60V, V _{GS} = 0V			1	μA
		V _{DS} =60V, V _{GS} = 0V, T _J =150°C			100	
Gate-body leakage current	I _{GSS}	V _{GS} =±20V, V _{DS} = 0V			±100	nA
Gate threshold voltage	V _{GS(th)}	V _{DS} =V _{GS} , I _D =250μA	1.2	1.75	2.5	V
Drain-source on-resistance	R _{DS(on)}	V _{GS} =10V, I _D =70A		2	2.5	mΩ
		V _{GS} =4.5V, I _D =20A		2.8	3.5	
Dynamic characteristics⁵⁾						
Input Capacitance	C _{iss}	V _{DS} =30V, V _{GS} =0V, f =1MHz		4320		pF
Output Capacitance	C _{oss}			1510		
Reverse Transfer Capacitance	C _{rss}			55		
Gate resistance	R _G	f =1.0MHz		2		Ω
Total Gate Charge	Q _g	V _{DS} =30V, V _{GS} =10V, I _D =47.5A		71		nC
Gate-Source Charge	Q _{gs}			17		
Gate-Drain Charge	Q _{gd}			11		
Turn-on delay time	t _{d(on)}	V _{DD} =30V, V _{GS} =10V, I _D =47.5A, R _{GEN} =3Ω		15		nS
Turn-on rise time	t _r			47		
Turn-off delay time	t _{d(off)}			53		
Turn-off fall time	t _f			19		
Source-Drain Diode characteristics						
Diode Forward Current	I _S				140	A
Diode Forward voltage	V _{SD}	V _{GS} =0V, I _S =70A			1.2	V
Reverse Recovery Time	t _{rr}	I _F =47.5A, di/dt =100A/μs		51		nS
Reverse Recovery Charge	Q _{rr}			51		nC

Notes:

- 1) Repetitive rating; pulse width limited by max. junction temperature.
- 2) T_J=25°C, V_G=10V, R_G=25Ω, L=4mH, I_{AS}=20A.
- 3) P_d is based on max. junction temperature, using junction-case thermal resistance.
- 4) The value of R_{θJA} is measured with the device mounted on 1in² FR-4 board with 2oz. Copper, in a still air environment with T_A =25°C. The maximum allowed junction temperature of 150°C. The value in any given application depends on the user's specific board design.
- 5) Guaranteed by design, not subject to production testing.

Typical Characteristics

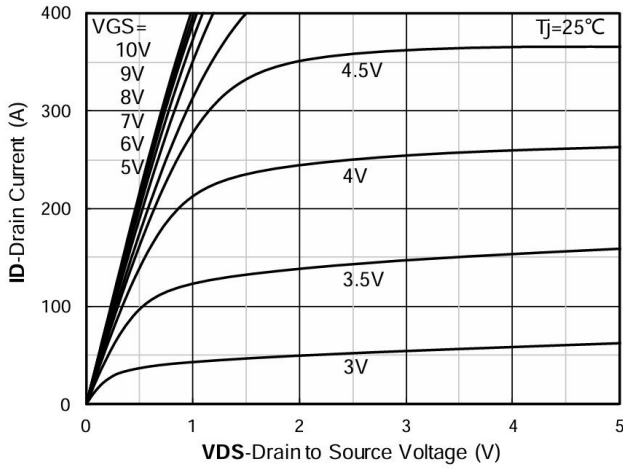

Figure 1. Output Characteristics

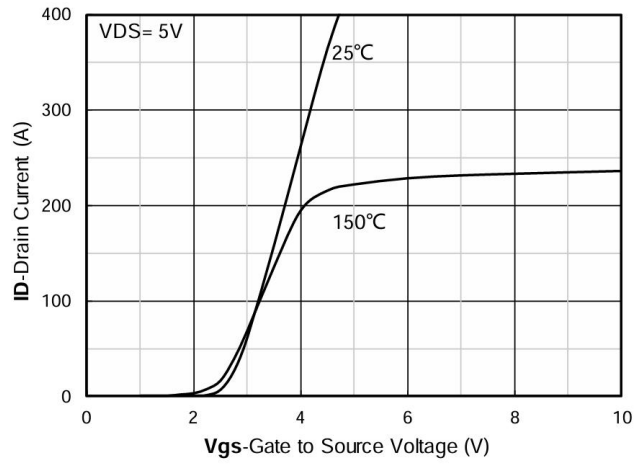

Figure 2. Transfer Characteristics

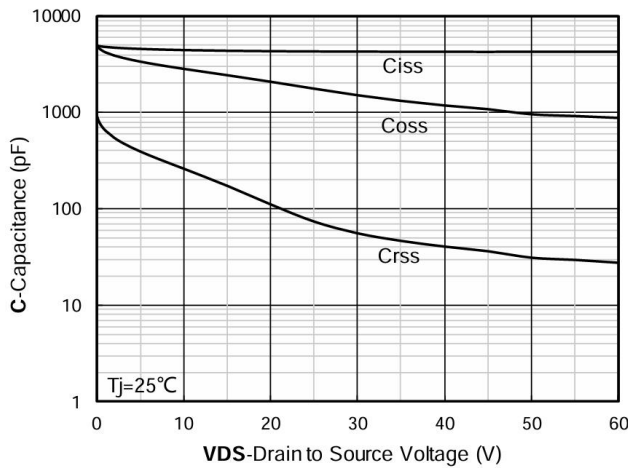

Figure 3. Capacitance Characteristics

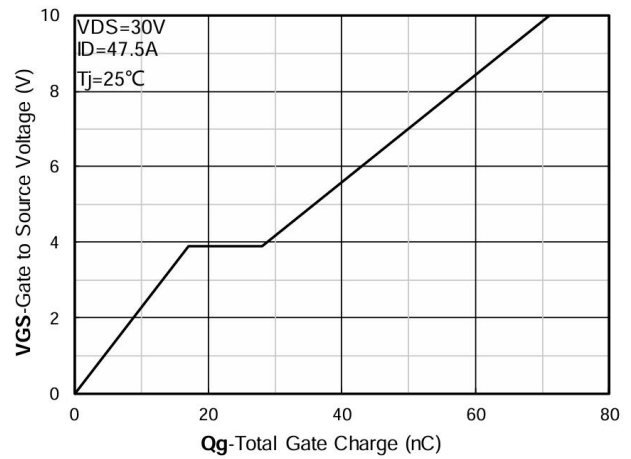

Figure 4. Gate Charge

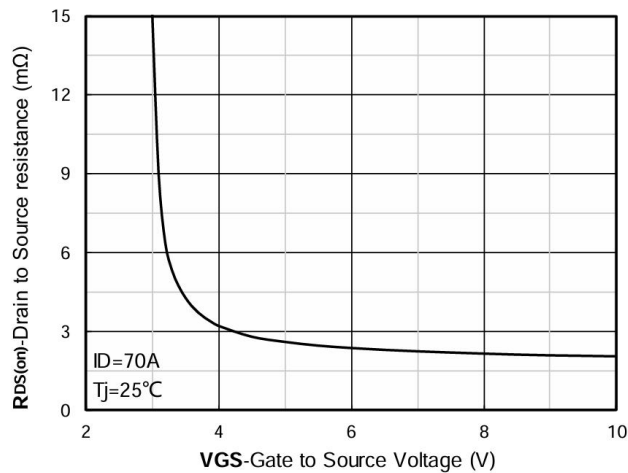

Figure 5. On-Resistance vs Gate to Source Voltage

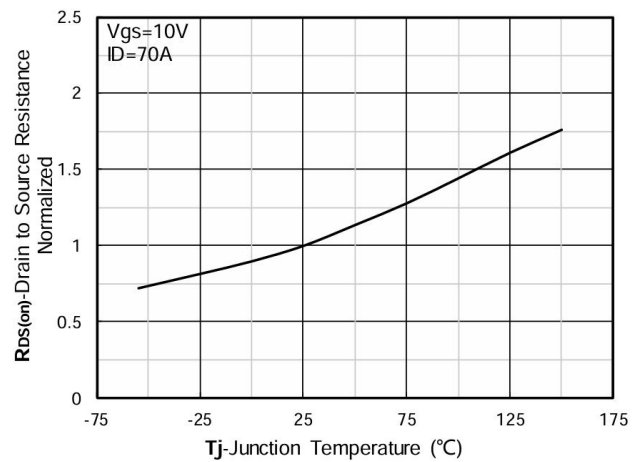

Figure 6. Normalized On-Resistance

Typical Characteristics

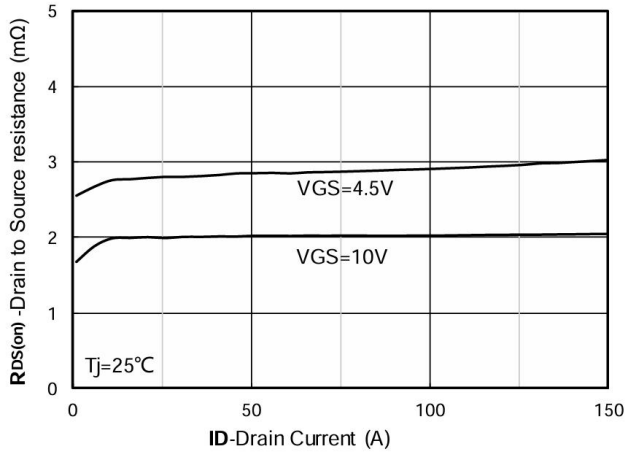

Figure 7. RDS(on) VS Drain Current

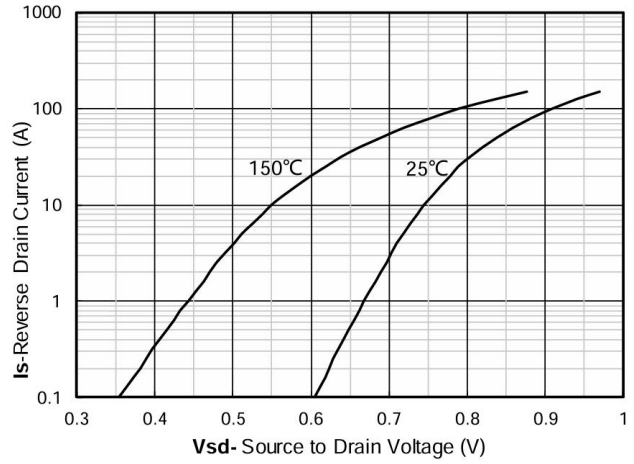

Figure 8. Forward characteristics of reverse diode

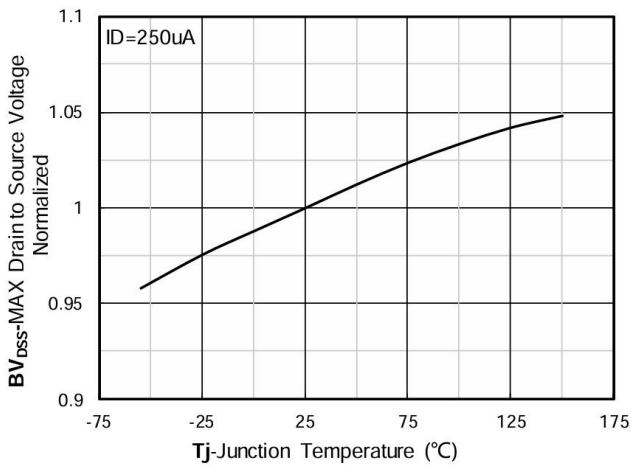

Figure 9. Normalized breakdown voltage

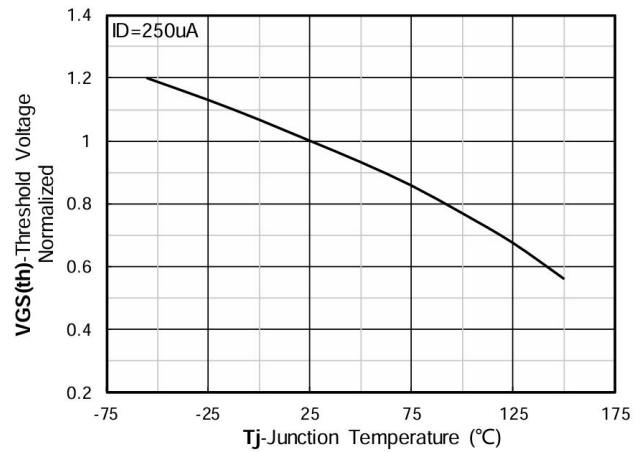

Figure 10. Normalized Threshold voltage

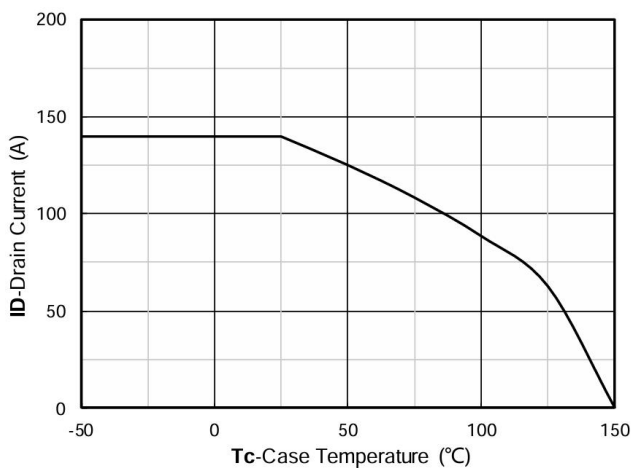

Figure 11. Current dissipation

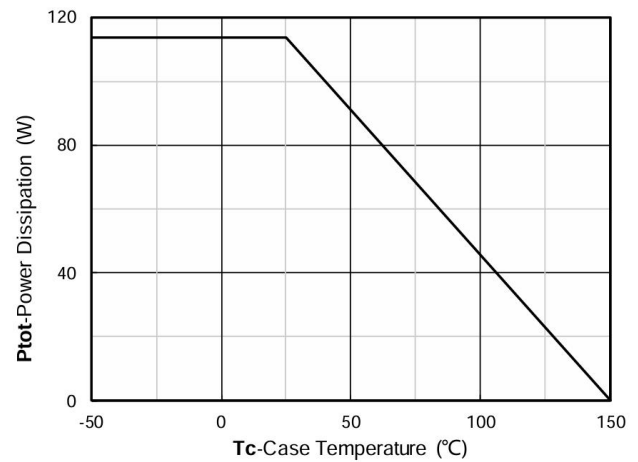

Figure 12. Power dissipation

Typical Characteristics

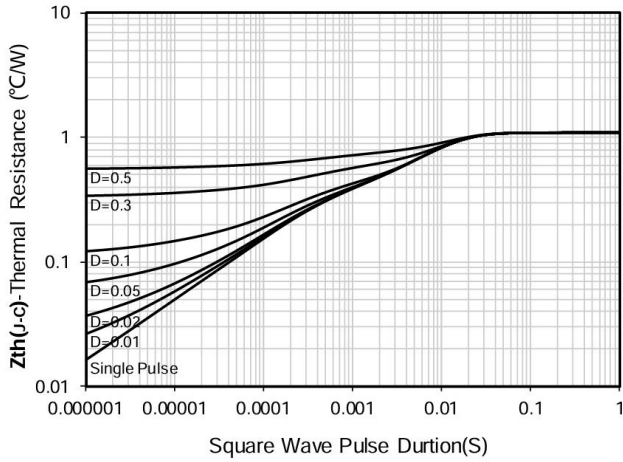

Figure 13. Maximum Transient Thermal Impedance

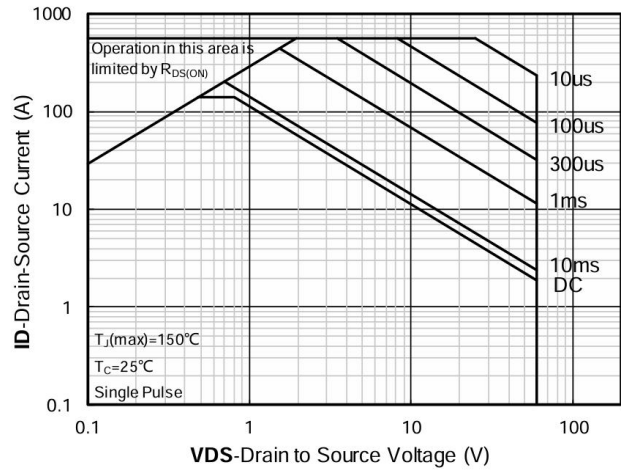
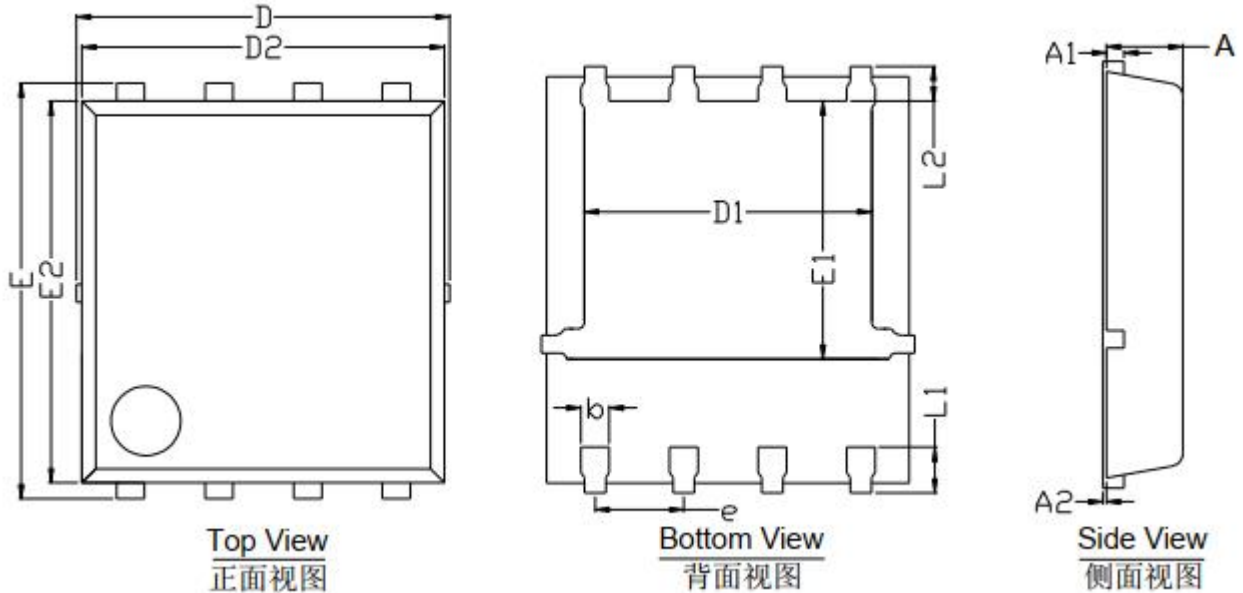

Figure 14. Safe Operation Area

PDFN5*6-8L Package Information



Symbol	Dimensions In Millimeters		Dimensions In Inches	
	Min.	Max.	Min.	Max.
D	5.150	5.550	0.203	0.219
E	5.950	6.350	0.234	0.250
A	1.000	1.200	0.039	0.047
A1	0.254 BSC		0.100 BSC	
A2	0.000	0.100	0.000	0.004
D1	3.920	4.320	0.154	0.170
E1	3.520	3.920	0.139	0.154
D2	5.000	5.400	0.197	0.213
E2	5.660	6.060	0.223	0.239
L1	0.560	0.760	0.022	0.030
L2	0.500 BSC		0.015 BSC	
b	0.310	0.510	0.012	0.020
e	1.270 BSC		0.050 BSC	