

Product Summary

$V_{(BR)DSS}$	$R_{DS(on)MAX}$	I_D
100V	4mΩ@10V	120A
	5mΩ@4.5V	

Feature

- Split gate trench MOSFET technology
- Excellent package for heat dissipation
- High density cell design for low $R_{DS(ON)}$
- Suffix "-Q1" for AEC-Q101

Application

- DC-DC converter
- Power switching application
- Uninterruptible power supply
- PD charger

Package

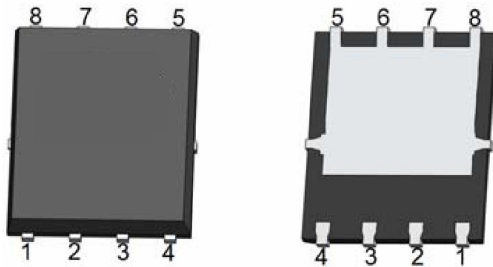

PDFN5*6-8L

Circuit diagram

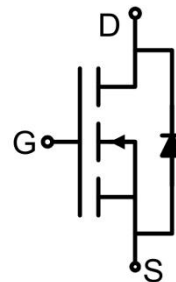

Marking

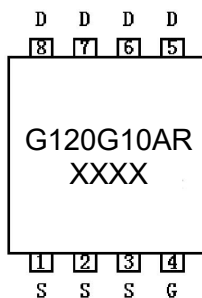

Absolute maximum ratings (T_A=25°C unless otherwise noted)

Parameter	Symbol	Value	Unit
Drain-Source Voltage	V _{DS}	100	V
Gate-Source Voltage	V _{GS}	±20	V
Continuous Drain Current(T _C =25°C)	I _D	120	A
Continuous Drain Current(T _C =100°C)	I _D (100°C)	76	A
Pulsed Drain Current ¹⁾	I _{DM}	480	A
Power Dissipation(T _C =25°C) ³⁾	P _D	108	W
Thermal Resistance,Junction-to-Ambient ⁴⁾	R _{θJA}	51	°C/W
Thermal Resistance,Junction-to-Case	R _{θJC}	1.16	°C/W
Single pulse avalanche energy ²⁾	E _{AS}	529	mJ
Junction Temperature	T _J	150	°C
Storage Temperature	T _{STG}	-55 ~ +150	°C

Electrical characteristics (T_J=25 °C, unless otherwise noted)

Parameter	Symbol	Test Condition	Min.	Typ.	Max.	Unit
Static Characteristics						
Drain-source breakdown voltage	V _{(BR)DSS}	V _{GS} = 0V, I _D =250μA	100			V
Zero gate voltage drain current	I _{DSS}	V _{DS} =100V, V _{GS} = 0V			1	μA
		V _{DS} =100V, V _{GS} = 0V, T _J =150°C			100	
Gate-body leakage current	I _{GSS}	V _{GS} =±20V, V _{DS} = 0V			±100	nA
Gate threshold voltage	V _{GS(th)}	V _{DS} =V _{GS} , I _D =250μA	1.0	1.8	2.5	V
Drain-source on-resistance	R _{DS(on)}	V _{GS} =10V, I _D =20A		3.2	4.0	mΩ
		V _{GS} =4.5V, I _D =20A		4.0	5.0	
Dynamic characteristics⁵⁾						
Input Capacitance	C _{iss}	V _{DS} =50V, V _{GS} =0V, f =1MHz		4400		pF
Output Capacitance	C _{oss}			1600		
Reverse Transfer Capacitance	C _{rss}			30		
Gate resistance	R _G	f =1.0MHz, Open drain		0.9		Ω
Total Gate Charge	Q _g	V _{DS} =50V, V _{GS} =10V, I _D =60A		65		nC
Gate-Source Charge	Q _{gs}			10		
Gate-Drain Charge	Q _{gd}			13		
Turn-on delay time	t _{d(on)}	V _{DD} =50V, V _{GS} =10V, I _D =60A, R _{GEN} =2.2Ω		25		nS
Turn-on rise time	t _r			90		
Turn-off delay time	t _{d(off)}			27		
Turn-off fall time	t _f			7		
Source-Drain Diode characteristics						
Diode Forward Current	I _S				120	A
Diode Forward voltage	V _{SD}	V _{GS} =0V, I _S =60A			1.2	V
Reverse Recovery Time	t _{rr}	I _F =60A, di/dt =350A/μs		35		nS
Reverse Recovery Charge	Q _{rr}				90	

Notes:

- 1) Repetitive rating; pulse width limited by max. junction temperature.
- 2) T_J=25°C, V_{DD}=50V, V_G=10V, R_G=25Ω, L=2mH, I_{AS}=23A.
- 3) P_d is based on max. junction temperature, using junction-case thermal resistance.
- 4) The value of R_{θJA} is measured with the device mounted on 1in2 FR-4 board with 2oz. Copper, in a still air environment with T_A =25°C. The maximum allowed junction temperature of 150°C. The value in any given application depends on the user's specific board design.
- 5) Guaranteed by design, not subject to production testing.

Typical Characteristics

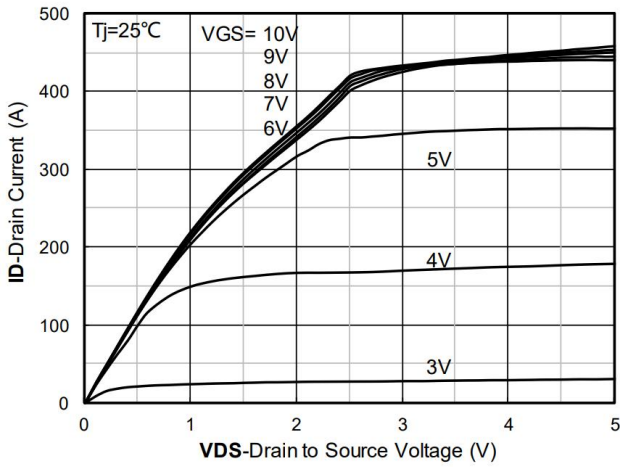

Figure1. Output Characteristics

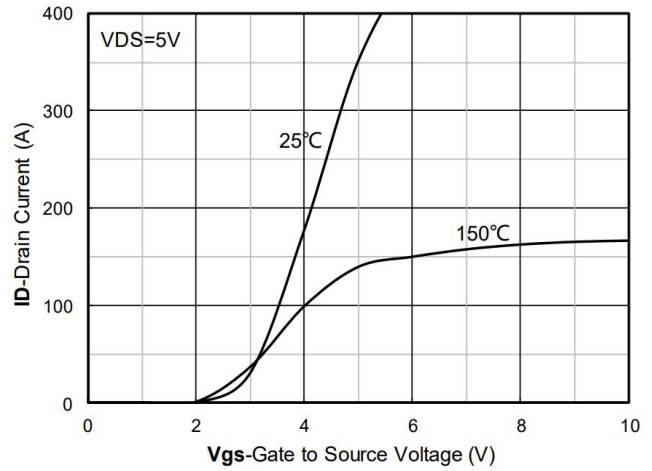

Figure2. Transfer Characteristics

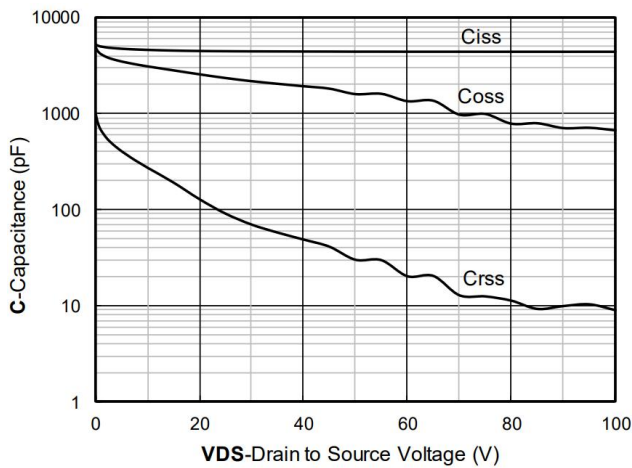

Figure3. Capacitance Characteristics

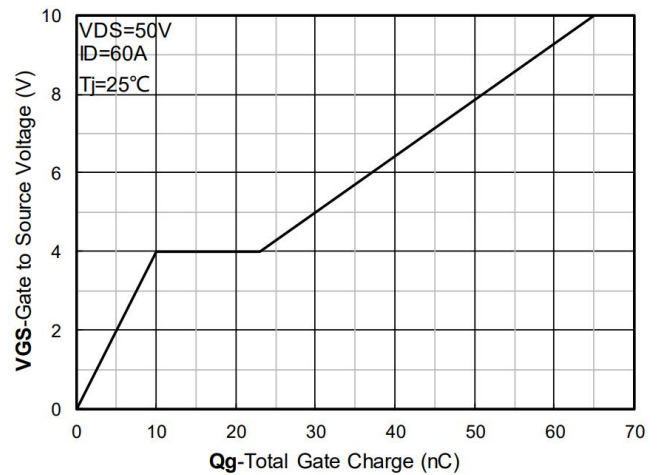

Figure4. Gate Charge

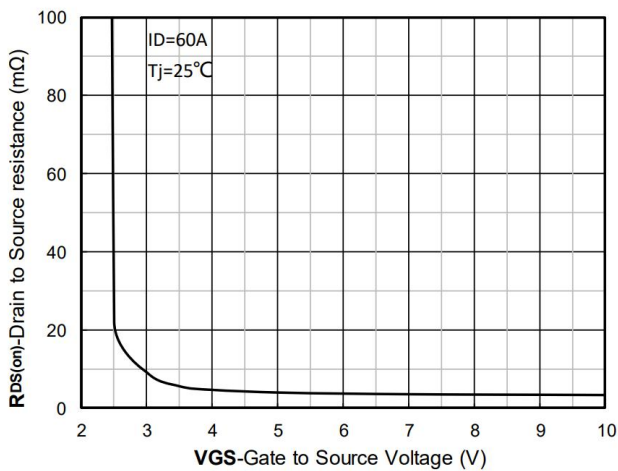

Figure5. On-Resistance vs Gate to Source Voltage

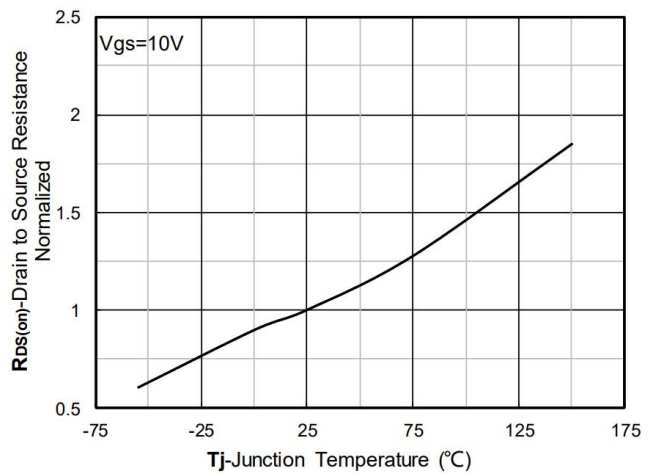

Figure6. Normalized On-Resistance

Typical Characteristics

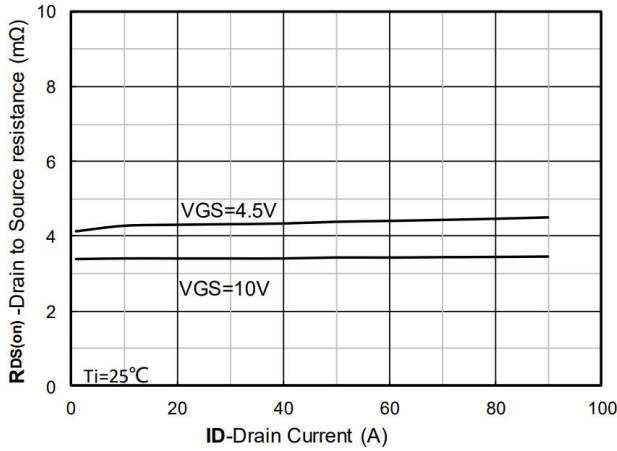

Figure 7. RDS(on) VS Drain Current

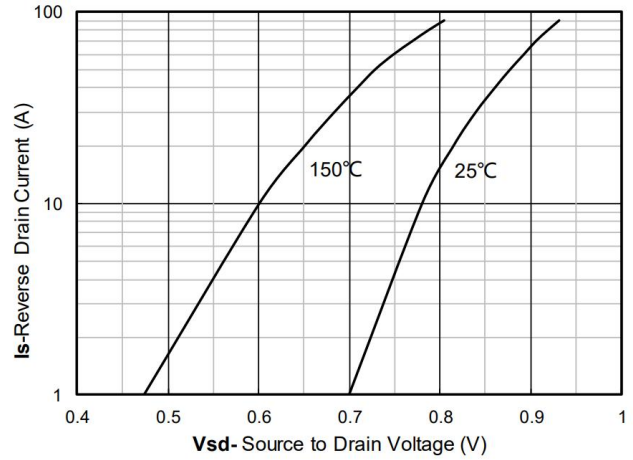

Figure 8. Forward characteristics of reverse diode

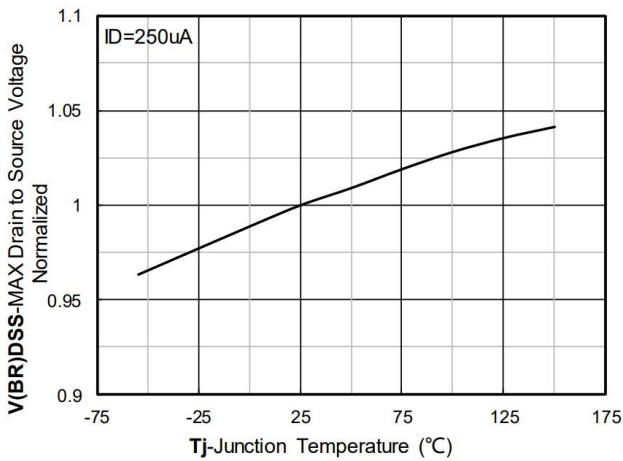

Figure 9. Normalized breakdown voltage

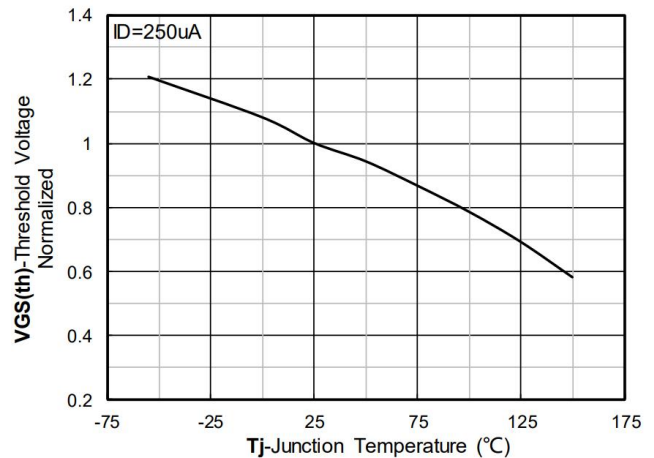

Figure 10. Normalized Threshold voltage

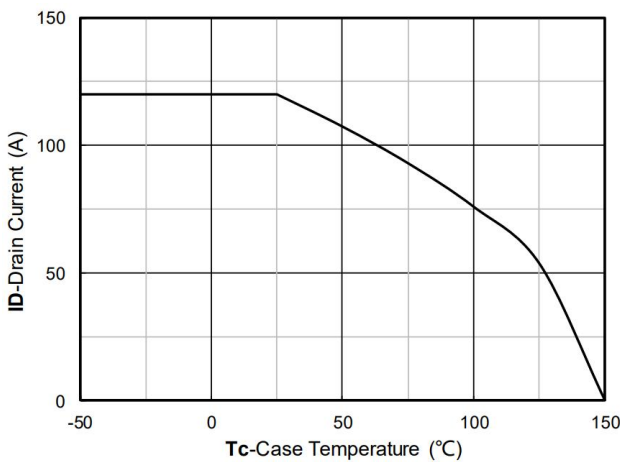

Figure 11. Current dissipation

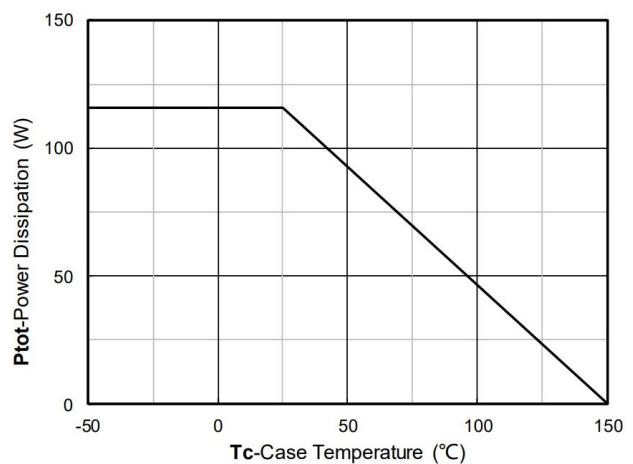

Figure 12. Power dissipation

Typical Characteristics

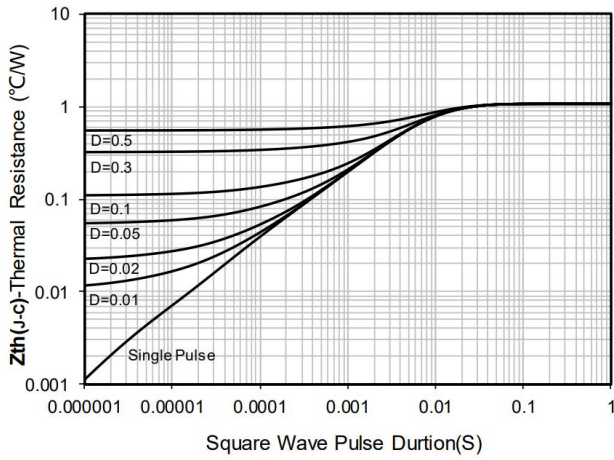

Figure13. Maximum Transient Thermal Impedance

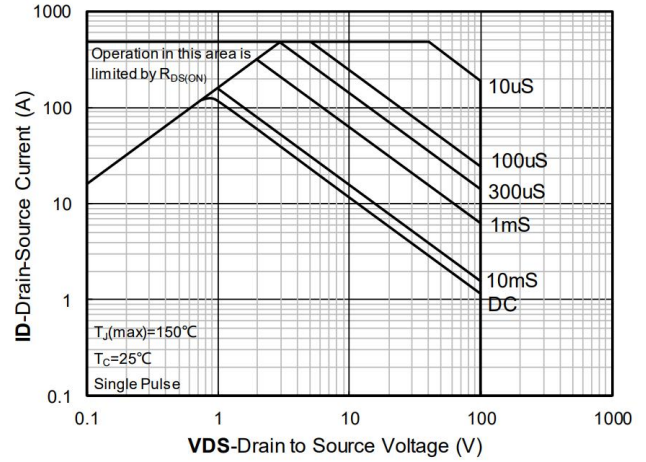
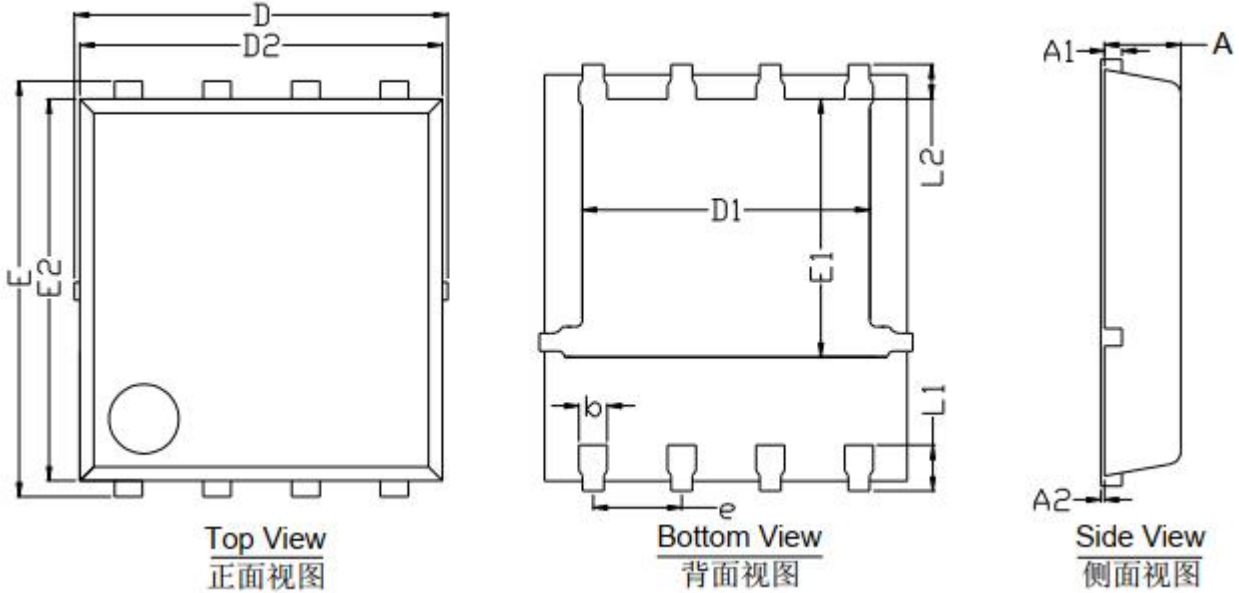

Figure14. Safe Operation Area

PDFN5*6-8L Package Information



Symbol	Dimensions In Millimeters		Dimensions In Inches	
	Min.	Max.	Min.	Max.
D	5.150	5.550	0.203	0.219
E	5.950	6.150	0.234	0.242
A	0.850	1.000	0.033	0.039
A1	0.203 BSC		0.008 BSC	
A2	0.000	0.080	0.000	0.003
D1	4.250	4.450	0.167	0.175
E1	3.525	3.725	0.139	0.147
D2	5.200 REF		0.205 REF	
E2	5.550 REF		0.219 REF	
L1	0.450	0.650	0.018	0.026
L2	0.680 BSC		0.268 BSC	
b	0.300	0.500	0.012	0.020
e	1.270 BSC		0.050 BSC	