

Product Summary

$V_{(BR)DSS}$	$R_{DS(on)MAX}$	I_D
40V	5.0mΩ@10V	80A
	6.5mΩ@4.5V	

Feature

- Excellent gate charge x $R_{DS(on)}$ product (FOM)
- Very low on-resistance $R_{DS(on)}$

Application

- DC-DC Converter
- Ideal for high-frequency switching and synchronous rectification

Package

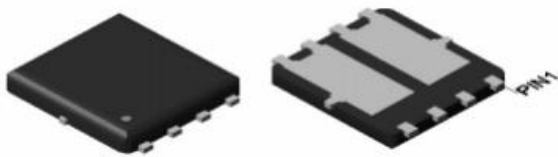

PDFN5*6-8L

Circuit diagram

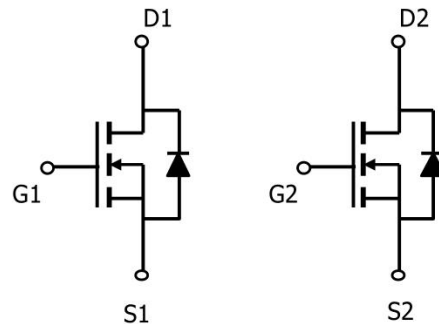

Marking



Absolute maximum ratings (T_c=25°C unless otherwise noted)

Parameter	Symbol	Value	Unit
Drain-Source Voltage	V _{DS}	40	V
Gate-Source Voltage	V _{GS}	±20	V
Continuous Drain Current	I _D	80	A
Continuous Drain Current(T _c =100°C)	I _D (100°C)	56.6	A
Pulsed Drain Current	I _{DM}	320	A
Power Dissipation	P _D	70	W
Derating factor	-	0.56	W/°C
Thermal Resistance,Junction-to-Case ¹⁾	R _{θJC}	1.8	°C/W
Single pulse avalanche energy ³⁾	E _{AS}	500	mJ
Junction Temperature	T _J	150	°C
Storage Temperature	T _{STG}	-55 ~ +150	°C

Electrical characteristics (T_c=25°C unless otherwise noted)

Parameter	Symbol	Test Condition	Min.	Typ.	Max.	Unit
Static Characteristics						
Drain-source breakdown voltage	V _{(BR)DSS}	V _{GS} = 0V, I _D =250μA	40			V
Zero gate voltage drain current	I _{DSS}	V _{DS} =40V,V _{GS} = 0V, T _J =25°C			1	μA
Gate-body leakage current	I _{GSS}	V _{GS} =±20V, V _{DS} = 0V			±100	nA
Gate threshold voltage ²⁾	V _{GS(th)}	V _{DS} =V _{GS} , I _D =250μA	1.0		2.2	V
Drain-source on-resistance ²⁾	R _{DS(on)}	V _{GS} =10V, I _D =20A		4.3	5.0	mΩ
		V _{GS} =4.5V, I _D =20A		5.5	6.5	mΩ
Forward Transconductance ²⁾	g _{FS}	V _{DS} =5V, I _D =20A		60		S
Dynamic characteristics⁴⁾						
Input Capacitance	C _{iss}	V _{DS} =20V,V _{GS} =0V,f =1MHz		2300		pF
Output Capacitance	C _{oss}			740		
Reverse Transfer Capacitance	C _{rss}			38		
Total Gate Charge	Q _g	V _{DS} =20V,V _{GS} =10V,I _D =20A		34.8		nC
Gate-Source Charge	Q _{gs}			6.2		
Gate-Drain Charge	Q _{gd}			5.1		
Turn-on delay time	t _{d(on)}	V _{DD} =20V,V _{GS} =10V, I _D =20A,R _G =1.6Ω		7.5		nS
Turn-on rise time	t _r			4		
Turn-off delay time	t _{d(off)}			37		
Turn-off fall time	t _f			7.5		
Source-Drain Diode characteristics						
Diode Forward voltage ²⁾	V _{SD}	V _{GS} =0V, I _S =20A			1.2	V
Diode Forward current ¹⁾	I _S				80	A
Reverse Recovery Time	t _{rr}	T _J =25°C, I _F =I _S ,		14		nS
Reverse Recovery Charge	Q _{rr}	dit/dt=100A/μs ²⁾		21		nC

Notes:

- 1) Surface Mounted on FR4 Board, t ≤ 10 sec.
- 2) Pulse Test: Pulse Width ≤ 300μs, Duty Cycle ≤ 2%.
- 3) EAS condition : T_J =25°C ,V_{DD} =20V,V_G =10V,L=0.5mH,R_G =25Ω
- 4) Guaranteed by design, not subject to production.

Typical Characteristics

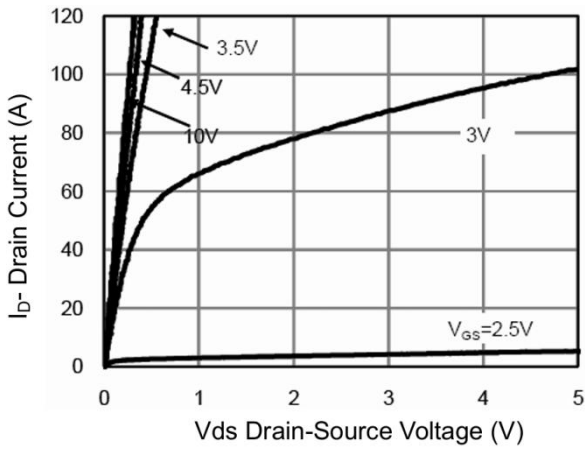

Figure 1 Output Characteristics

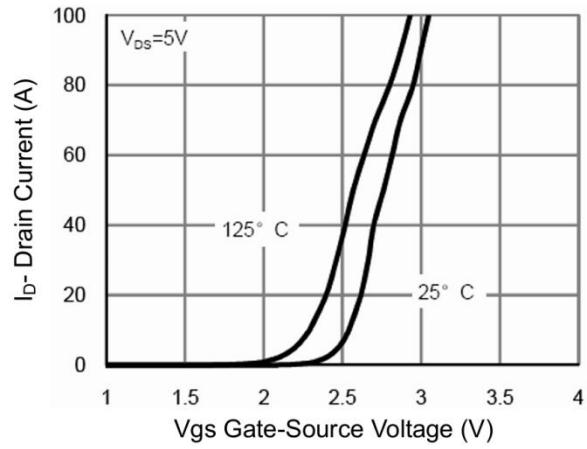

Figure 2 Transfer Characteristics

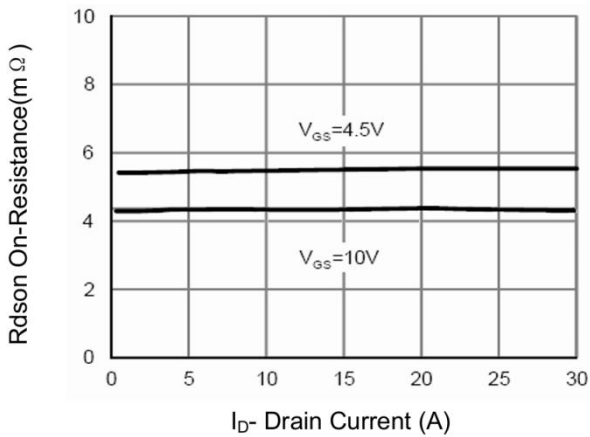

Figure 3 Rdson- Drain Current

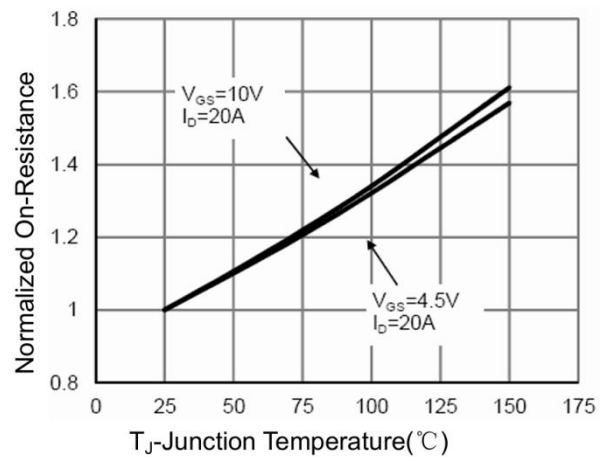

Figure 4 Rdson-Junction Temperature

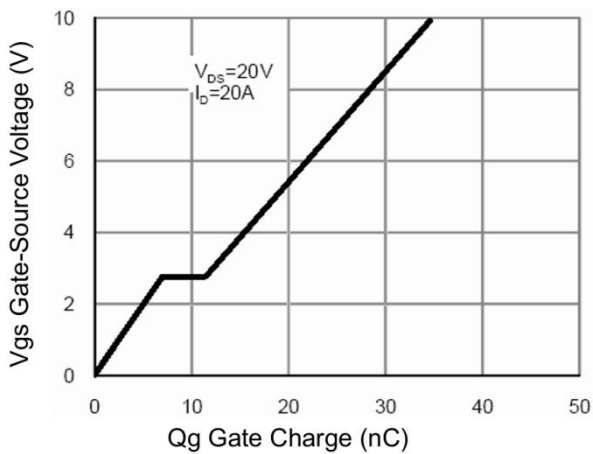

Figure 5 Gate Charge

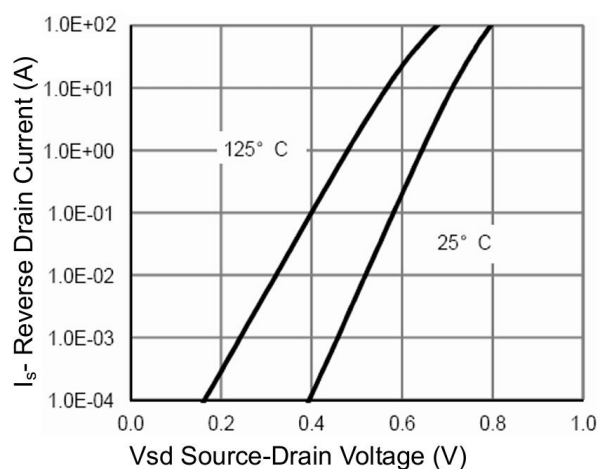

Figure 6 Source- Drain Diode Forward

Typical Characteristics

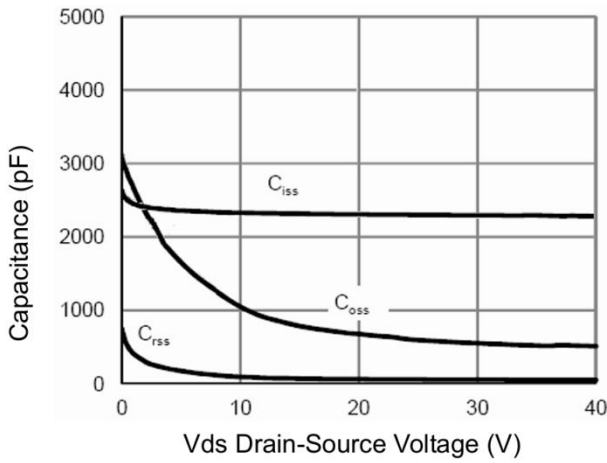

Figure 7 Capacitance vs Vds

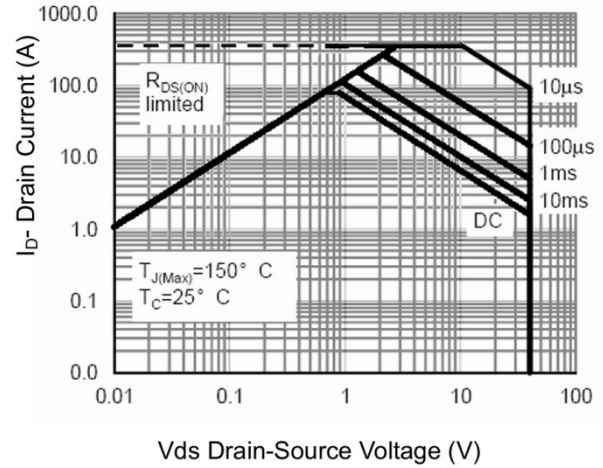

Figure 8 Safe Operation Area

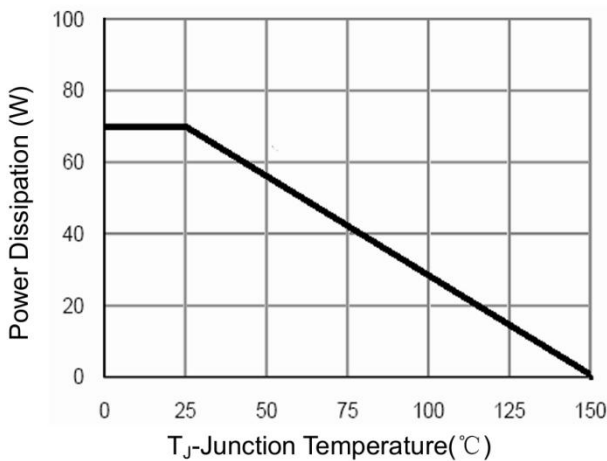

Figure 9 Power De-rating

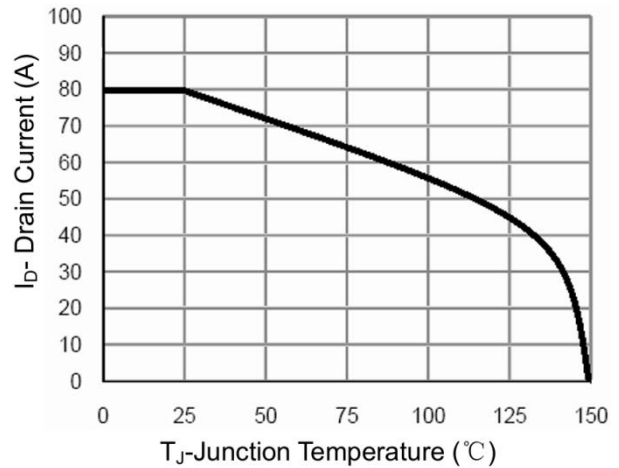

Figure 10 Current De-rating

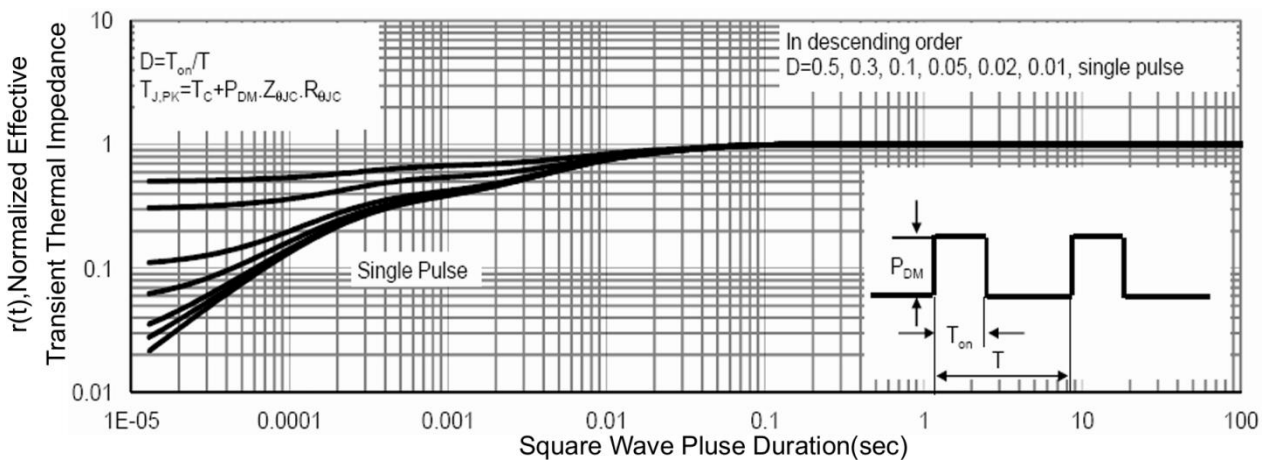
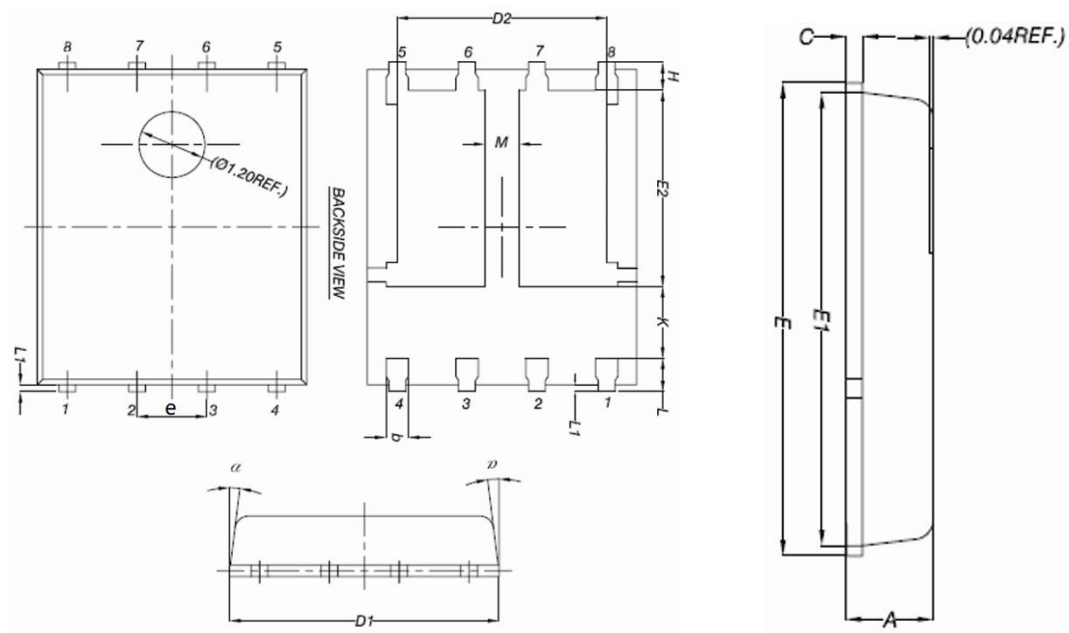

Figure 11 Normalized Maximum Transient Thermal Impedance

PDFN5*6-8L Package Information



Symbol	Dimensions In Millimeters		Dimensions In Inches	
	Min.	Max.	Min.	Max.
A	0.900	1.100	0.035	0.043
b	0.330	0.510	0.013	0.020
C	0.200	0.300	0.008	0.012
D1	4.800	5.000	0.189	0.197
D2	3.610	3.960	0.142	0.156
E	5.900	6.100	0.232	0.240
E1	5.700	5.800	0.224	0.228
E2	3.380	3.780	0.133	0.149
e	1.270 BSC		0.050 BSC	
H	0.410	0.610	0.016	0.024
K	1.100	-	0.043	-
L	0.510	0.710	0.020	0.028
L1	0.060	0.200	0.002	0.008
M	0.500	-	0.020	-
α	0°	12°	0°	12°