

Product Summary

$V_{(BR)DSS}$	$R_{DS(on)MAX}$	I_D
150V	8.8mΩ@10V	96.5A

Feature

- Excellent gate charge x $R_{DS(on)}$ product (FOM)
- Very low on-resistance $R_{DS(on)}$

Application

- DC-DC converter
- Ideal for high-frequency switching and synchronous rectification

Package

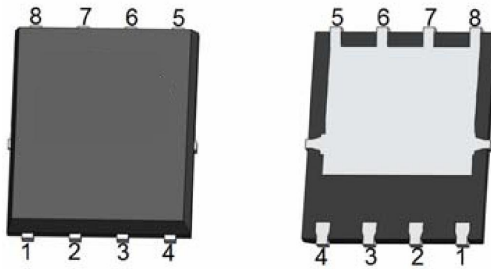

PDFN5*6-8L

Circuit diagram

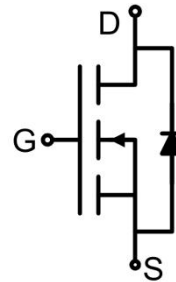

Marking

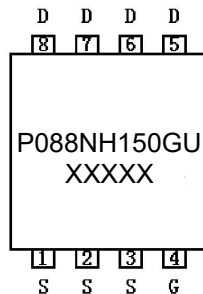

Absolute maximum ratings (T_c=25°C unless otherwise noted)

Parameter	Symbol	Value	Unit
Drain-Source Voltage	V _{DS}	150	V
Gate-Source Voltage	V _{GS}	±20	V
Continuous Drain Current	I _D	96.5	A
Continuous Drain Current (T _c =100°C)	I _D (100°C)	60.5	A
Pulsed Drain Current	I _{DM}	386	A
Power Dissipation	P _D	180	W
Derating factor		1.44	W/°C
Thermal Resistance,Junction-to-Case	R _{θJC}	0.7	°C/W
Single pulse avalanche energy ¹⁾	E _{AS}	501	mJ
Junction Temperature	T _J	150	°C
Storage Temperature	T _{STG}	-55 ~ +150	°C

Electrical characteristics (T_c=25 °C, unless otherwise noted)

Parameter	Symbol	Test Condition	Min.	Typ.	Max.	Unit
Static Characteristics						
Drain-source breakdown voltage	V _{(BR)DSS}	V _{GS} = 0V, I _D =250μA	150			V
Zero gate voltage drain current	I _{DSS}	V _{DS} =150V, V _{GS} = 0V			1	μA
Gate-body leakage current	I _{GSS}	V _{GS} =±20V, V _{DS} = 0V			±100	nA
Gate threshold voltage	V _{GS(th)}	V _{DS} =V _{GS} , I _D =250μA	2.5	3.3	4.5	V
Drain-source on-resistance	R _{DS(on)}	V _{GS} =10V, I _D =20A		7.8	8.8	mΩ
Forward Transconductance	g _{FS}	V _{DS} =10V, I _D =40A		30		S
Dynamic characteristics²⁾						
Input Capacitance	C _{iss}	V _{DS} =75V, V _{GS} =0V, f =1MHz		2738		pF
Output Capacitance	C _{oss}			932		
Reverse Transfer Capacitance	C _{rss}			30		
Total Gate Charge	Q _g	V _{DS} =75V, V _{GS} =10V, I _D =20A		48		nC
Gate-Source Charge	Q _{gs}			15		
Gate-Drain Charge	Q _{gd}			14.5		
Turn-on delay time	t _{d(on)}	V _{DD} =75V, V _{GS} =10V, I _D =40A, R _G =4.7Ω		15		nS
Turn-on rise time	t _r			70		
Turn-off delay time	t _{d(off)}			30		
Turn-off fall time	t _f			10		
Source-Drain Diode characteristics						
Diode Forward Current	I _S				96.5	A
Diode Forward voltage	V _{SD}	V _{GS} =0V, I _F =20A			1.2	V
Reverse Recovery Time	t _{rr}	T _J =25°C, I _F =40A, di/dt =100A/μs		88		nS
Reverse Recovery Charge	Q _{rr}			222		nC

Notes:

1) EAS condition : T_J=25°C, V_{DD}=50V, V_G=10V, L=0.5mH, R_g=25Ω.

2) Guaranteed by design, not subject to production testing.

Typical Characteristics

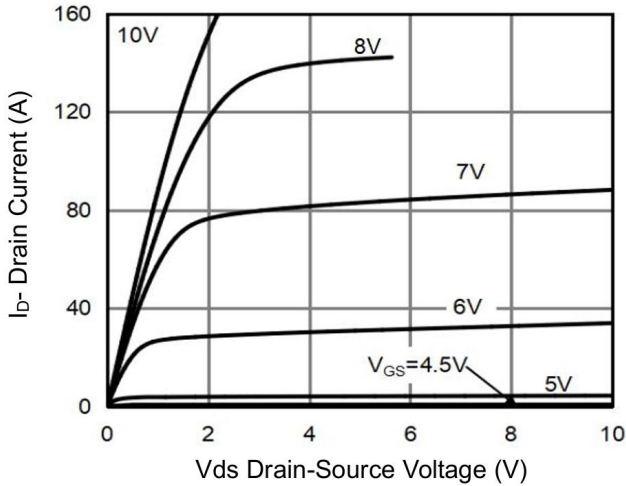

Figure 1 Output Characteristics

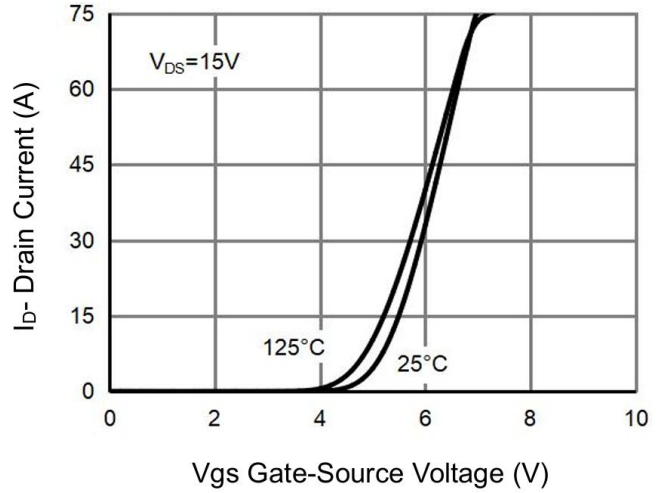

Figure 2 Transfer Characteristics

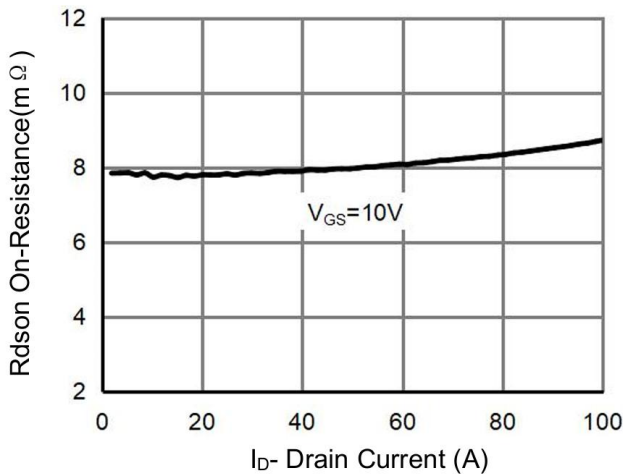

Figure 3 Rdson- Drain Current

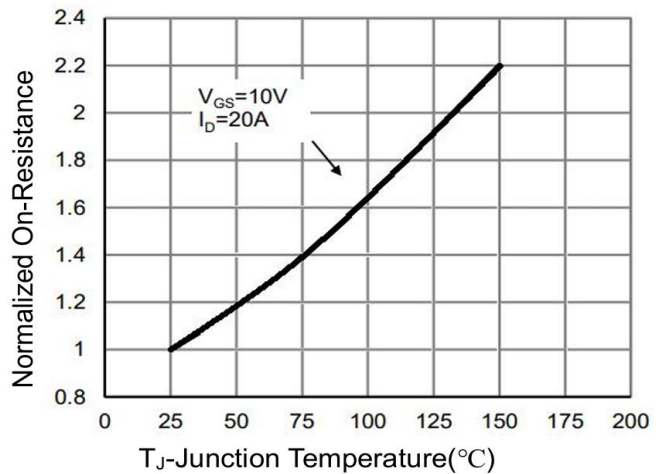

Figure 4 Rdson-Junction Temperature

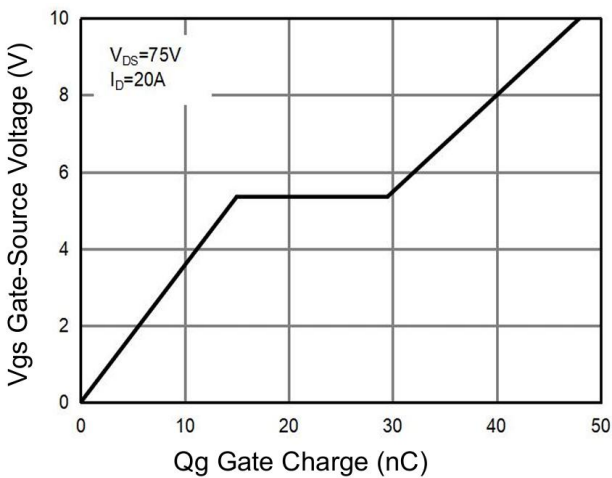

Figure 5 Gate Charge

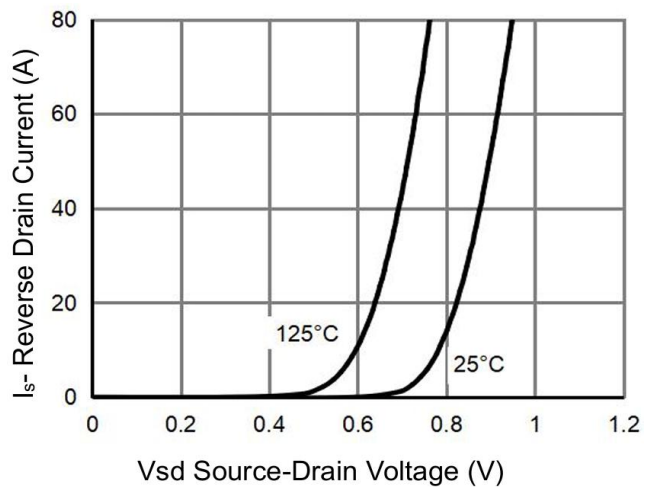

Figure 6 Source- Drain Diode Forward

Typical Characteristics

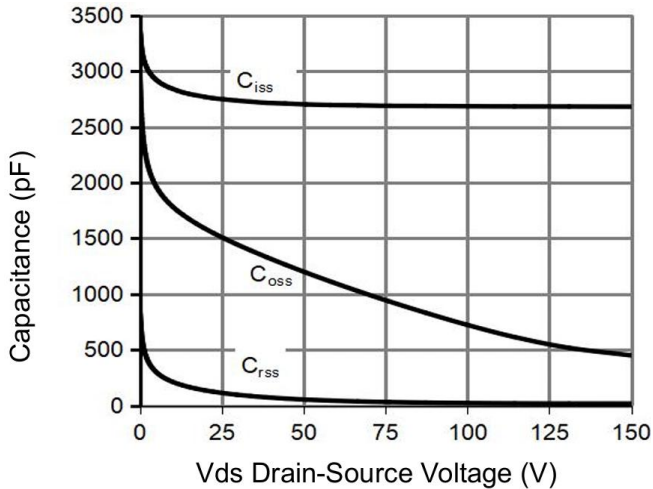

Figure 7 Capacitance vs Vds

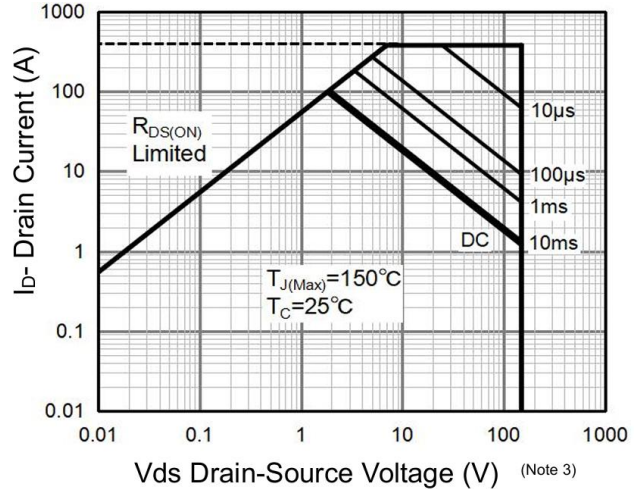

Figure 8 Safe Operation Area

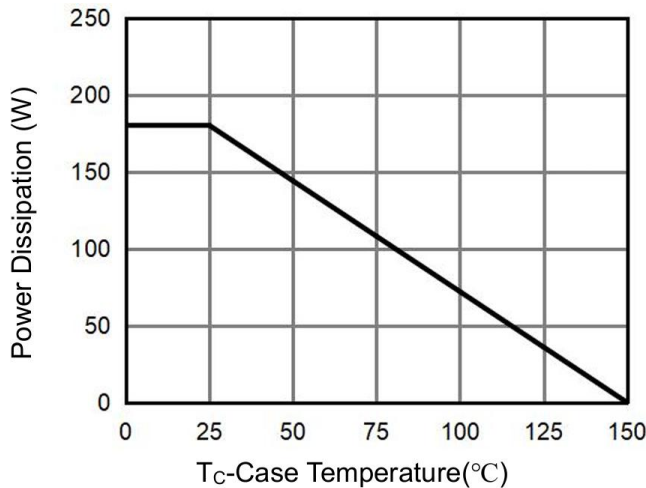

Figure 9 Power De-rating

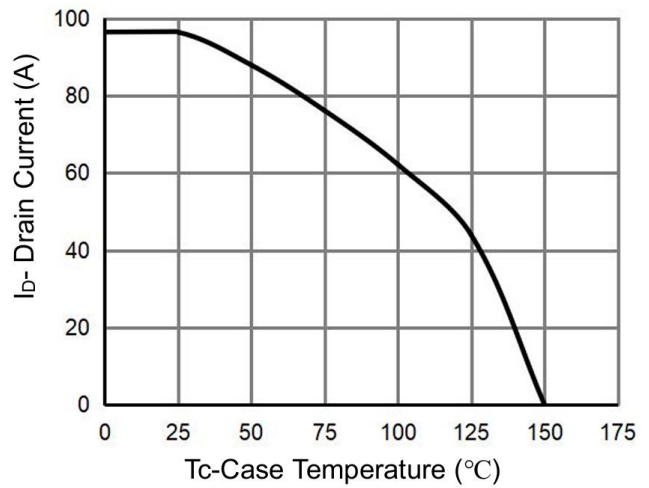

Figure 10 Current De-rating

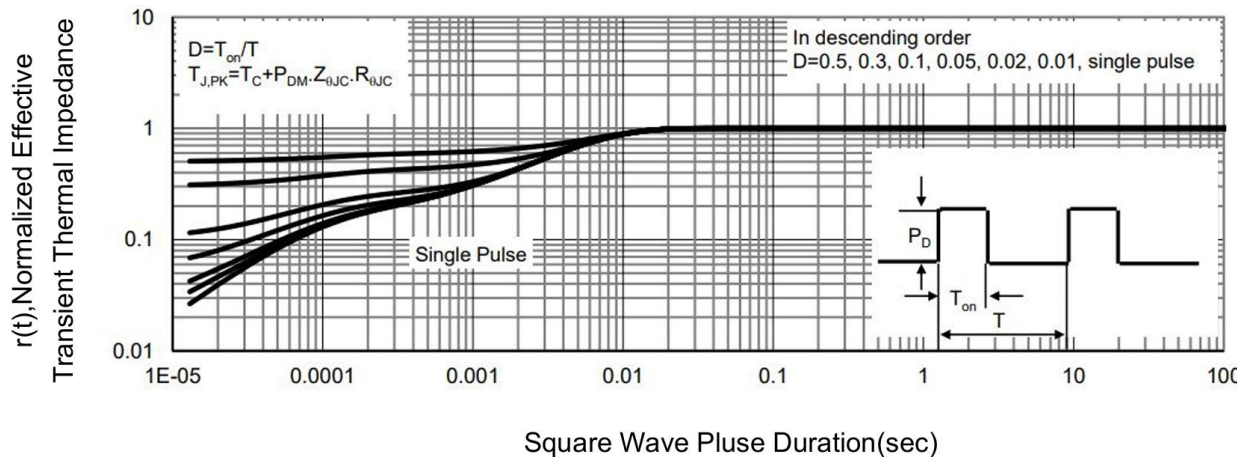
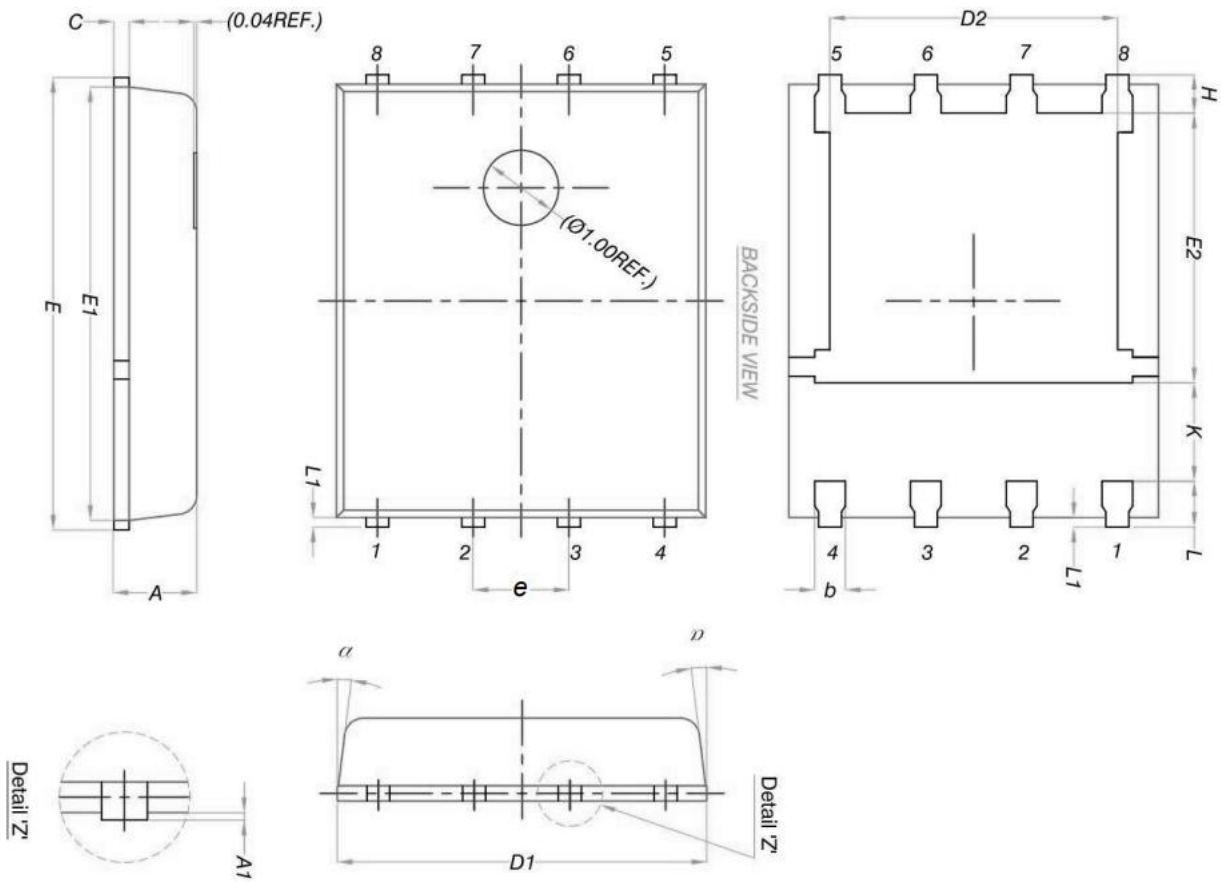

Figure 11 Normalized Maximum Transient Thermal Impedance

PDFN5*6-8L Package Information



Symbol	Dimensions In Millimeters		Dimensions In Inches	
	Min.	Max.	Min.	Max.
A	0.900	1.100	0.035	0.043
A1	0.000	0.050	0.000	0.002
b	0.330	0.510	0.013	0.020
C	0.200	0.300	0.008	0.012
D1	4.800	5.000	0.189	0.197
D2	3.610	3.960	0.142	0.156
E	5.900	6.100	0.232	0.240
E1	5.700	5.800	0.224	0.228
E2	3.380	3.780	0.133	0.149
e	1.270 BSC		0.050 BSC	
H	0.410	0.610	0.016	0.024
K	1.100	-	0.043	-
L	0.510	0.710	0.020	0.028
L1	0.060	0.200	0.002	0.008
α	0°	12°	0°	12°