

Product Summary

$V_{(BR)DSS}$	$R_{DS(on)MAX}$	I_D
60V	3.5mΩ@10V	150A
	5.0mΩ@4.5V	

Feature

- High density cell design for low Rdson
- Split gate trench MOSFET technology
- Excellent package for good heat dissipation

Application

- Synchronous rectification
- Battery protection circuit
- Motor drivers and uninterruptible power supplies

Package



TO-263AB

Circuit diagram

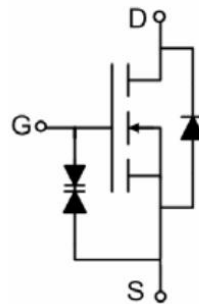

Marking

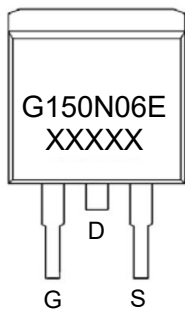

Absolute maximum ratings (Ta=25°C unless otherwise noted)

Parameter	Symbol	Value	Unit
Drain-Source Voltage	V _{DS}	60	V
Gate-Source Voltage	V _{GS}	±20	V
Continuous Drain Current	I _D	150	A
Continuous Drain Current (100°C)	I _D (100°C)	95	A
Pulsed Drain Current	I _{DM}	450	A
Power Dissipation	P _D	147	W
Thermal Resistance from Junction to Ambient	R _{θJA}	60	°C/W
Thermal Resistance from Junction to Case	R _{θJC}	0.85	°C/W
Single pulse avalanche energy	E _{AS}	441	mJ
Junction Temperature	T _J	150	°C
Storage Temperature	T _{STG}	-55 ~ +150	°C

Electrical characteristics (T_J=25 °C, unless otherwise noted)

Parameter	Symbol	Test Condition	Min.	Typ.	Max.	Unit
Static Characteristics						
Drain-source breakdown voltage	V _{(BR)DSS}	V _{GS} = 0V, I _D =250μA	60			V
Zero gate voltage drain current	I _{DSS}	V _{DS} =60V, V _{GS} = 0V			1	μA
Gate-body leakage current	I _{GSS}	V _{GS} =±20V, V _{DS} = 0V			±10	μA
Gate threshold voltage	V _{GS(th)}	V _{DS} =V _{GS} , I _D =250μA	1.0	1.7	2.5	V
Drain-source on-resistance	R _{DS(on)}	V _{GS} =10V, I _D =20A		2.7	3.5	mΩ
		V _{GS} =4.5V, I _D =20A		3.5	5.0	
Dynamic characteristics²⁾						
Input Capacitance	C _{iss}	V _{DS} =30V, V _{GS} =0V, f =1MHz		4650		pF
Output Capacitance	C _{oss}			850		
Reverse Transfer Capacitance	C _{rss}			65		
Total Gate Charge	Q _g	V _{DS} =30V, V _{GS} =10V, I _D =25A		71		nC
Gate-Source Charge	Q _{gs}			17		
Gate-Drain Charge	Q _{gd}			10.5		
Turn-on delay time	t _{d(on)}	V _{DD} =30V, V _{GS} =10V, I _D =25A, R _{GEN} =2Ω		15.9		nS
Turn-on rise time	t _r			55.2		
Turn-off delay time	t _{d(off)}			57.5		
Turn-off fall time	t _f			91.3		
Source-Drain Diode characteristics						
Diode Forward Current	I _S				150	A
Diode Forward voltage	V _{DS}	V _{GS} =0V, I _S =20A			1.3	V
Reverse Recovery Time	t _{rr}	T _J = 25°C, I _F =20A		41.6		nS
Reverse Recovery Charge	Q _{rr}	di/dt = 100A/μs ¹⁾		39.8		nC

Notes:

- 1) Pulse Test: Pulse Width < 300μs, Duty Cycle ≤2%.
- 2) Guaranteed by design, not subject to production testing.

Typical Characteristics

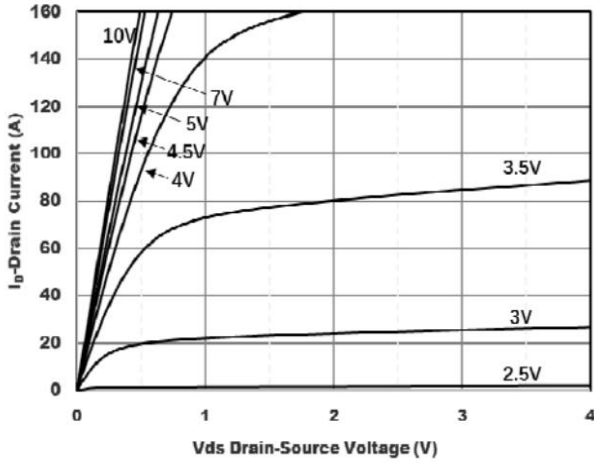

Figure1. Output Characteristics

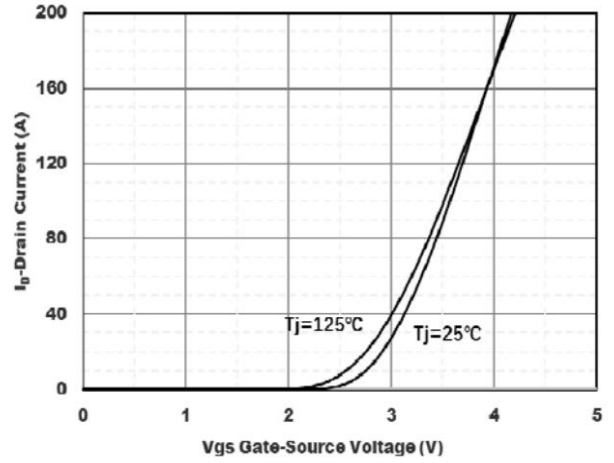

Figure2. Transfer Characteristics

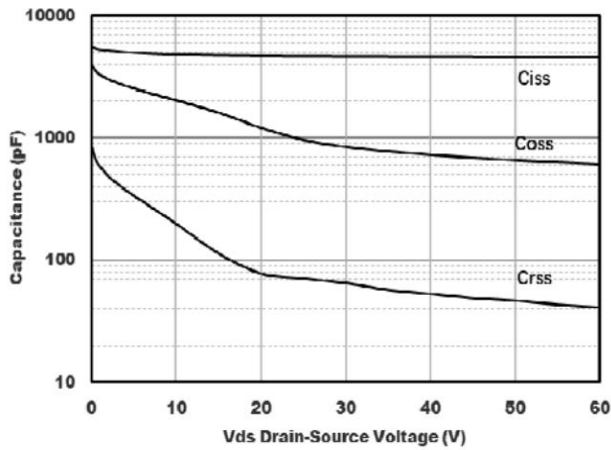

Figure3. Capacitance Characteristics

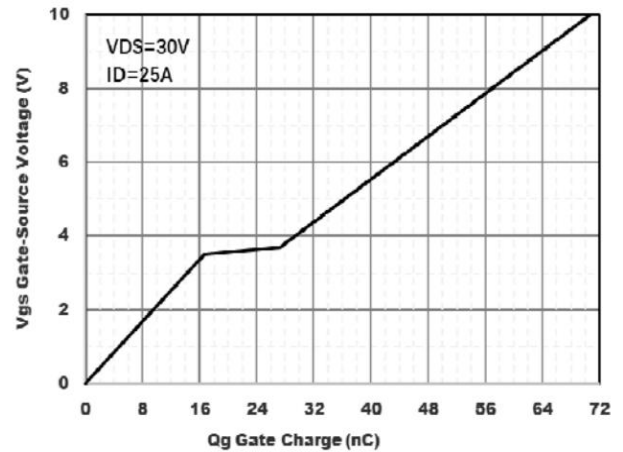

Figure4. Gate Charge

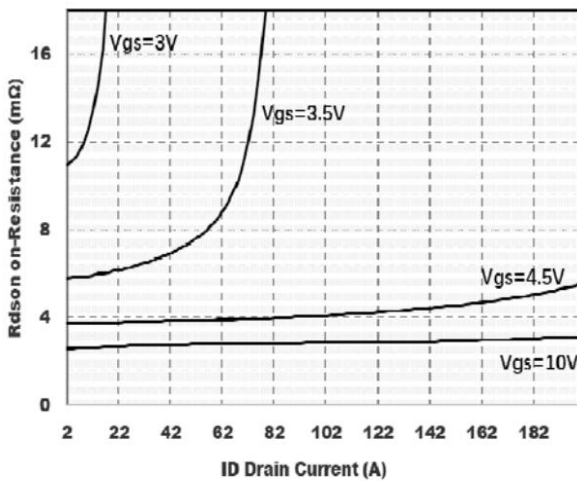

Figure5. : On-Resistance vs. Drain Current and Gate Voltage

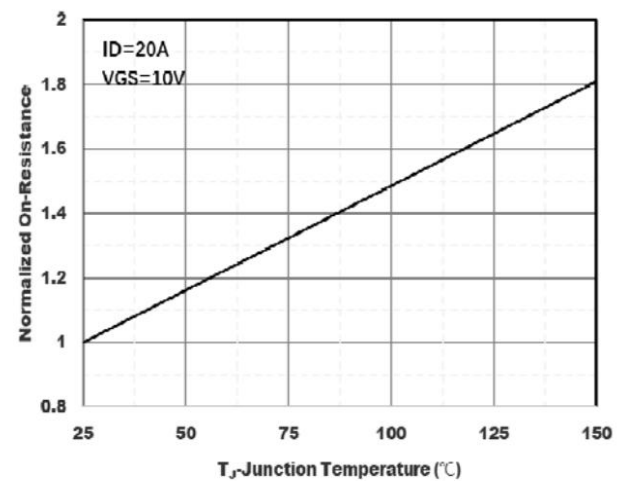

Figure6. Normalized On-Resistance

Typical Characteristics

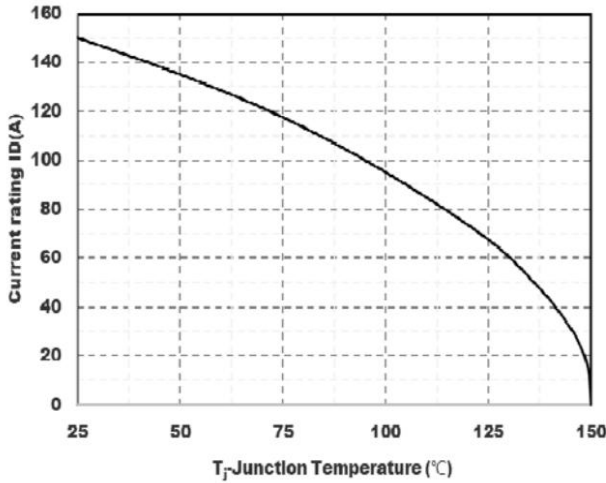

Figure7. Drain current

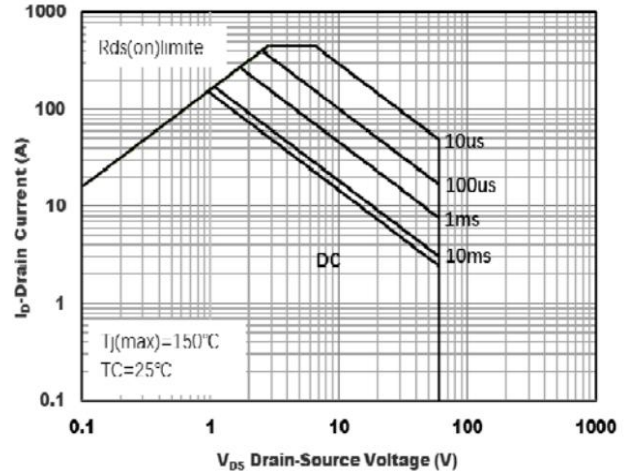

Figure8.Safe Operation Area

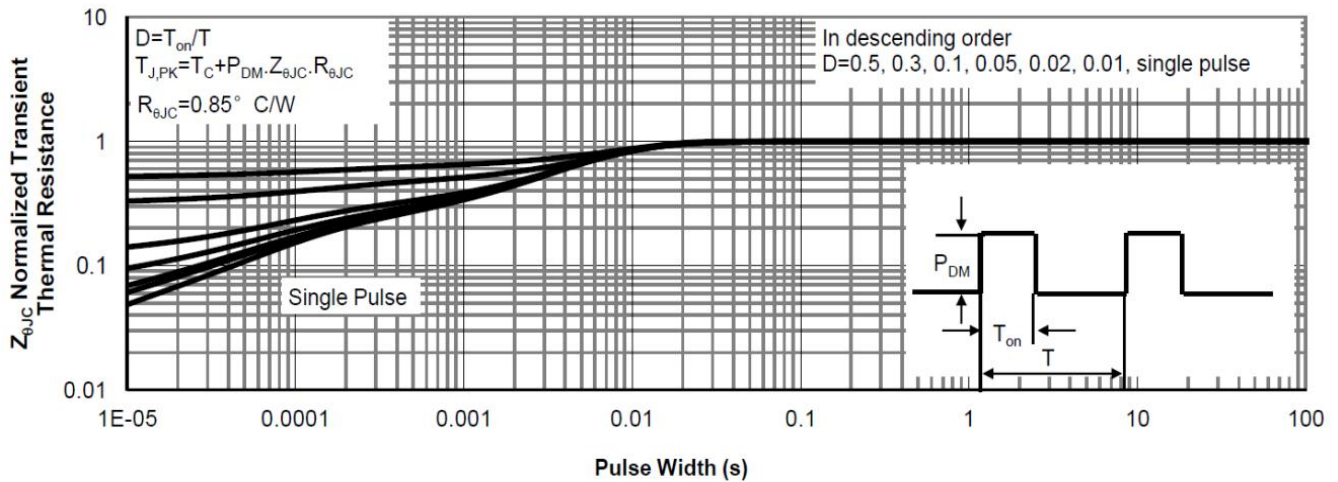
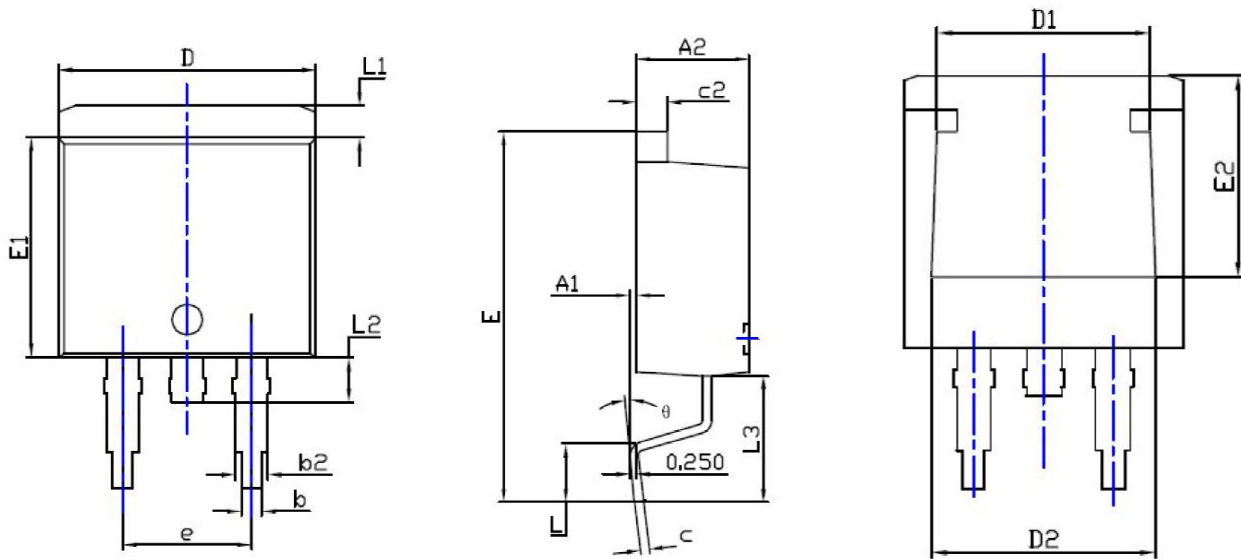

Figure9.Normalized Maximum Transient thermal impedance

TO-263AB Package Information



Symbol	Dimensions In Millimeters		Dimensions In Inches	
	Min.	Max.	Min.	Max.
A1	0.000	0.250	0.000	0.010
A2	4.430	4.730	0.174	0.186
b	0.720	0.920	0.028	0.036
b2	1.180	1.380	0.046	0.054
c	0.330	0.450	0.013	0.018
c2	1.220	1.340	0.048	0.053
D	10.000	10.300	0.394	0.406
D1	7.500	8.100	0.295	0.319
D2	7.700	8.300	0.303	0.327
E	14.500	15.500	0.571	0.610
E1	8.550	8.850	0.337	0.348
E2	7.000	7.600	0.276	0.299
e	5.080 BSC		0.200 BSC	
L	1.790	2.790	0.070	0.110
L1	1.120	1.420	0.044	0.056
L2	0.770	1.770	0.030	0.070
L3	5.000 REF		0.197 REF	
θ	0°	8°	0°	8°