

Product Summary

$V_{(BR)DSS}$	$R_{DS(on)MAX}$	I_D
100V	2.6m Ω @10V	200A

Feature

- Excellent gate charge x $R_{DS(on)}$ product (FOM)
- Very low on-resistance $R_{DS(on)}$
- Suffix "-Q1" for AEC-Q101

Application

- DC-DC converter
- Ideal for high-frequency switching and synchronous rectification

Package



TO-263AB

Circuit Diagram

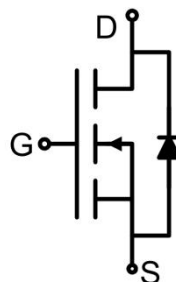

Marking

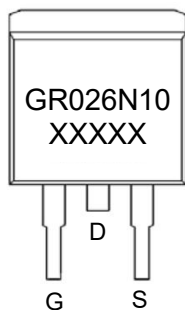

Absolute Maximum Ratings (T_C=25°C unless otherwise noted)

Parameter	Symbol	Value	Unit
Drain-Source Voltage	V _{DS}	100	V
Gate-Source Voltage	V _{GS}	±20	V
Continuous Drain Current	I _D	200	A
Continuous Drain Current(T _C =100°C)	I _D (100°C)	142	A
Pulsed Drain Current	I _{DM}	800	A
Power Dissipation	P _D	300	W
Thermal Resistance,Junction-to-Case ¹⁾	R _{θJC}	0.5	°C/W
Avalanche Energy ⁴⁾	E _{AS}	2300	mJ
Junction Temperature	T _J	175	°C
Storage Temperature	T _{STG}	-55 ~ +175	°C

Electrical Characteristics (T_C=25 °C unless otherwise noted)

Parameter	Symbol	Test Condition	Min.	Typ.	Max.	Unit
Static Characteristics						
Drain-Source Breakdown Voltage	V _{(BR)DSS}	V _{GS} = 0V, I _D =250μA	100			V
Zero Gate Voltage Drain Current	I _{DSS}	V _{DS} =100V,V _{GS} = 0V			1	μA
Gate-Body Leakage Current	I _{GSS}	V _{GS} =±20V, V _{DS} = 0V			±100	nA
Gate Threshold Voltage ²⁾	V _{GS(th)}	V _{DS} =V _{GS} , I _D =250μA	2.0	3.0	4.0	V
Drain-Source on-Resistance ²⁾	R _{DS(on)}	V _{GS} =10V, I _D =100A		2.2	2.6	mΩ
Forward Transconductance ²⁾	g _{FS}	V _{DS} =5V, I _D =100A		90		S
Dynamic Characteristics³⁾						
Input Capacitance	C _{iss}	V _{DS} =50V,V _{GS} =0V,f =1MHz		17500		pF
Output Capacitance	C _{oss}			1100		
Reverse Transfer Capacitance	C _{riss}			50		
Gate Resistance ²⁾	R _g			2.5		Ω
Total Gate Charge	Q _g	V _{DS} =50V,V _{GS} =10V, I _D =100A		240		nC
Gate-Source Charge	Q _{gs}			75		
Gate-Drain Charge	Q _{gd}			60		
Turn-on Delay Time	t _{d(on)}	V _{DD} =50V, V _{GS} =10V, I _D =100A, R _G =1.6Ω		34		nS
Turn-on Rise Time	t _r			27		
Turn-off Delay Time	t _{d(off)}			78		
Turn-off Fall Time	t _f			30		
Source-Drain Diode Characteristics						
Diode Forward Current ¹⁾	I _S				200	A
Diode Forward voltage ²⁾	V _{SD}	V _{GS} =0V, I _S =100A			1.2	V
Reverse Recovery Time	t _{rr}	T _J =25°C, I _F =100A, di/dt=100A/μs ²⁾		101		nS
Reverse Recovery Charge	Q _{rr}			280		nC

Notes:

- 1) The value of R_{θJA} is measured with the device mounted on 1in2 FR-4 board with 2oz. Copper, in a still air environment with T_A=25° C. The Power dissipation P_{DSM} is based on R_{θJA} and the maximum allowed junction temperature of 150° C. The value in any given application depends on the user's specific board design, and the maximum temperature of 175° C may be used if the PCB allows it.
- 2) Pulse Test: Pulse Width ≤ 300μs, Duty Cycle ≤ 2%.
- 3) Guaranteed by design, not subject to production
- 4) EAS condition : T_J=25°C, V_{DD}=50V, V_G=10V, L=0.5mH, R_G=25Ω

Typical Characteristics

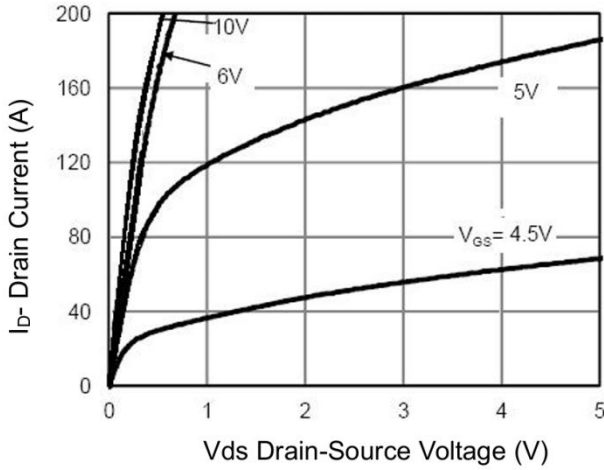

Figure 1 Output Characteristics

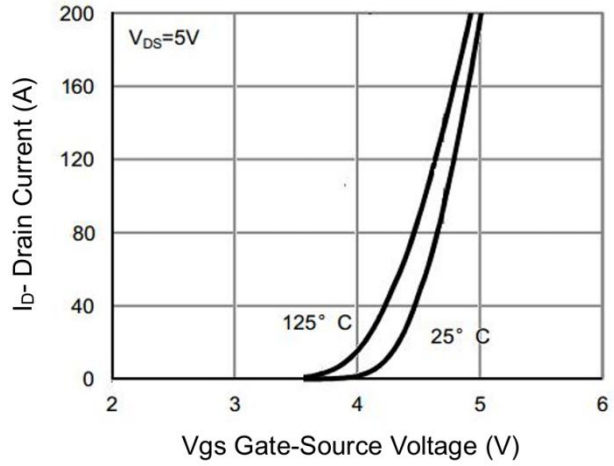

Figure 2 Transfer Characteristics

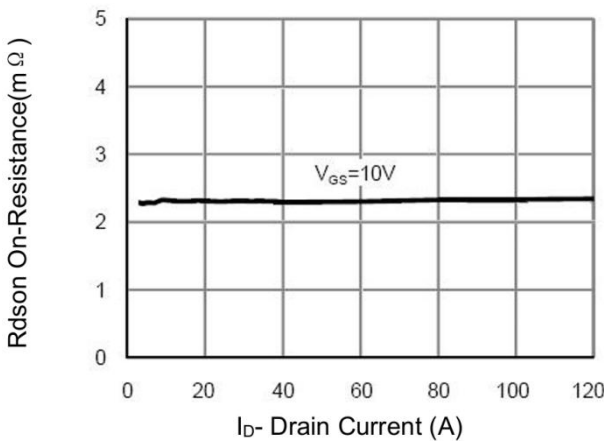

Figure 3 Rdson- Drain Current

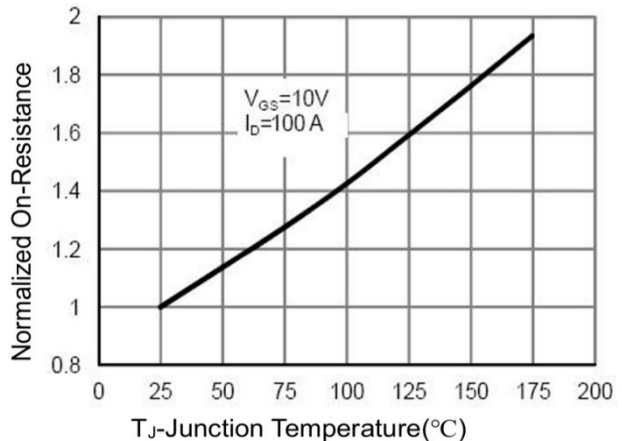

Figure 4 Rdson-Junction Temperature

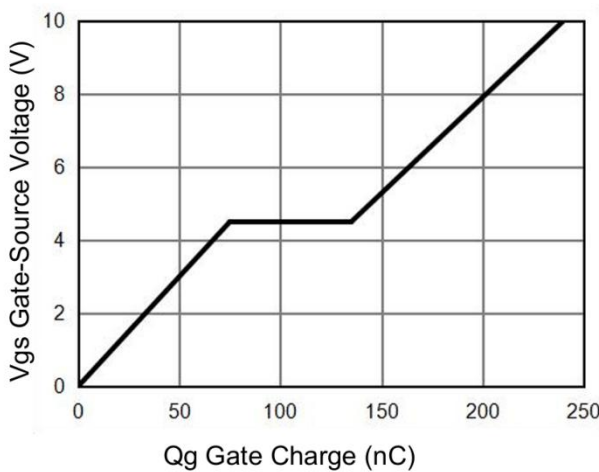

Figure 5 Gate Charge

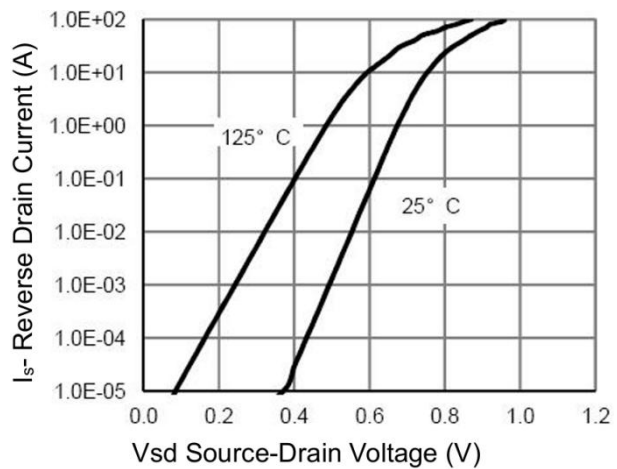

Figure 6 Source- Drain Diode Forward

Typical Characteristics

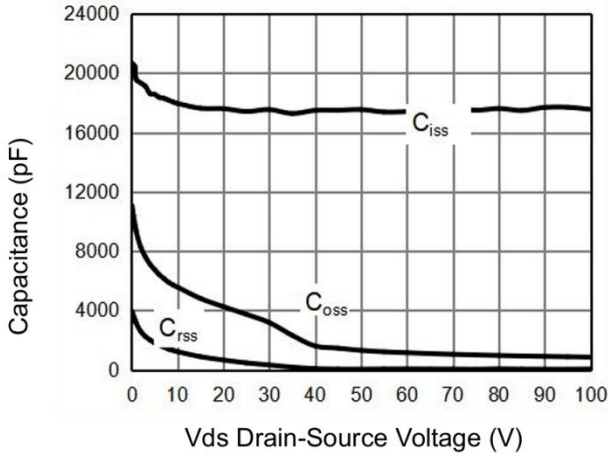

Figure 7 Capacitance vs Vds

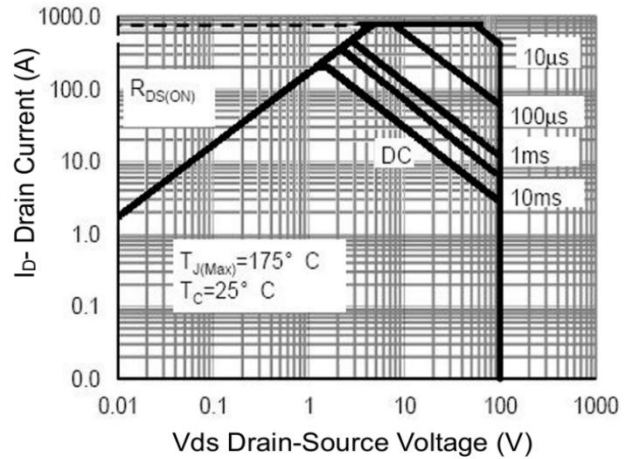

Figure 8 Safe Operation Area

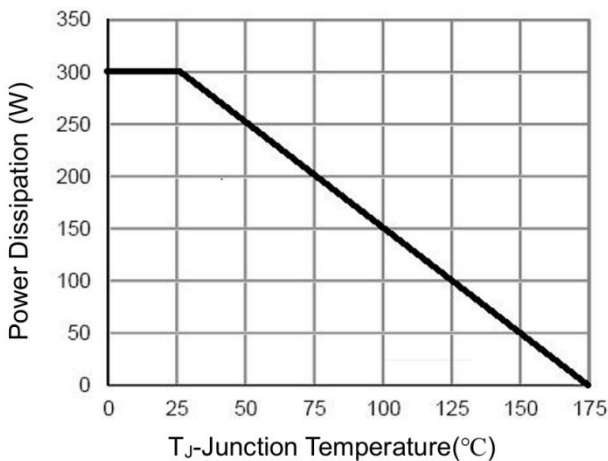

Figure 9 Power De-rating

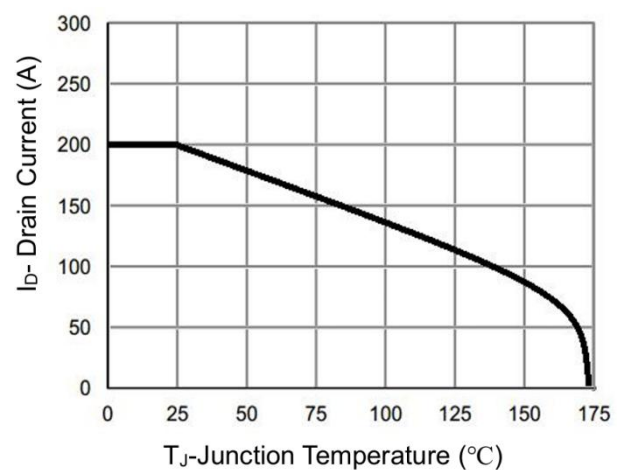

Figure 10 Current De-rating

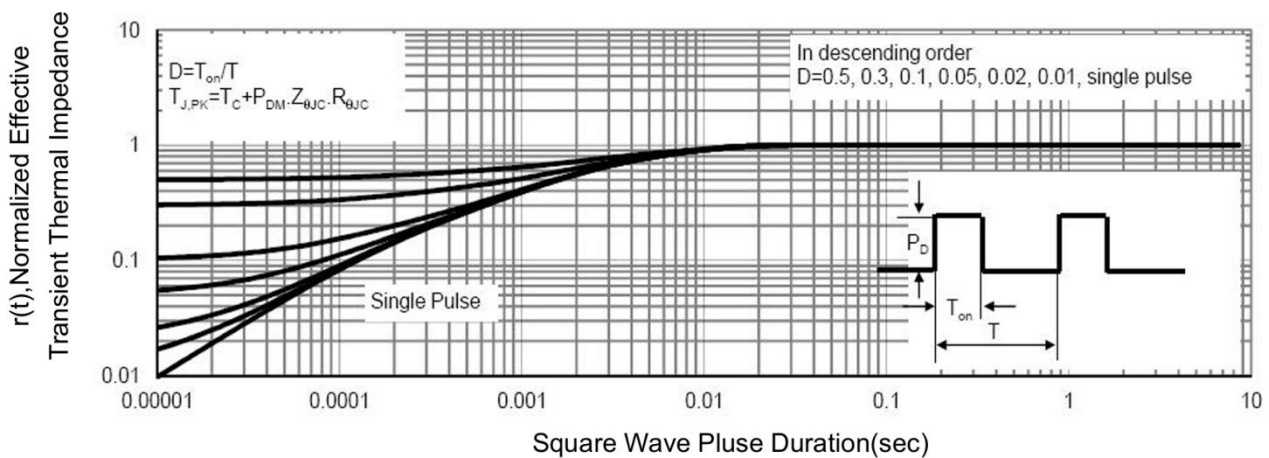
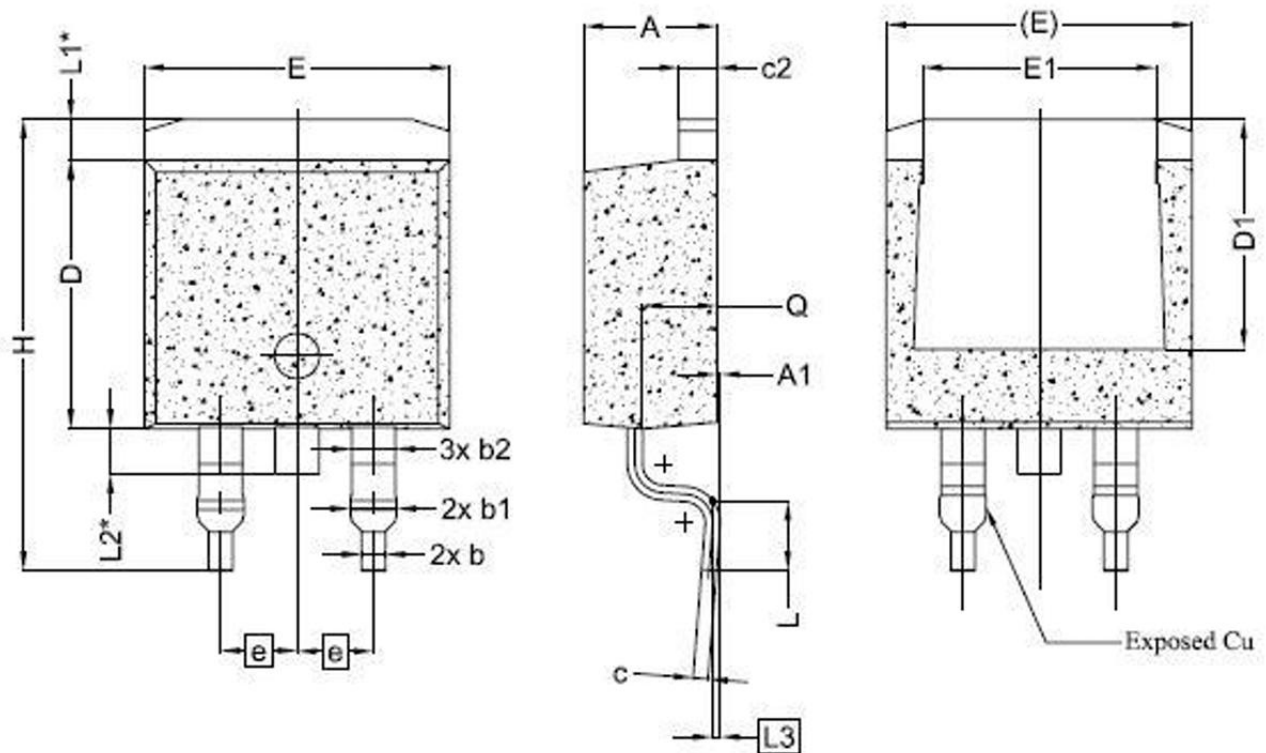

Figure 11 Normalized Maximum Transient Thermal Impedance

TO-263AB Package Information



Symbol	Dimensions In Millimeters		Dimensions In Inches	
	Min.	Max.	Min.	Max.
A	4.240	4.640	0.167	0.183
A1	0.000	0.250	0.000	0.010
b	0.700	0.900	0.028	0.035
b1	1.200	1.750	0.047	0.069
b2	1.200	1.700	0.047	0.067
c	0.400	0.600	0.016	0.024
c2	1.150	1.400	0.045	0.055
D	8.820	9.020	0.347	0.355
D1	6.860	-	0.270	-
E	9.960	10.360	0.392	0.408
E1	6.890	7.890	0.271	0.311
e	2.540 BSC		0.100 BSC	
H	14.610	15.880	0.575	0.625
L	1.780	2.790	0.070	0.110
L1	1.360 REF		0.054 REF	
L2	1.500 RFE		0.197 REF	
L3	0.250 BSC		0.010 BSC	
Q	2.300	2.700	0.091	0.106