

Product Summary

$V_{(BR)CES}$	$V_{CE(SAT)MAX}$	$I_c(100^\circ C)$
650V	2.15V@15V	30A

Feature

- Low switching losses
- Positive temperature coefficient
- High ruggedness, temperature stable
- High short circuit capability

Application

- Inverter for motor drive
- AC and DC servo drive amplifier
- Uninterruptible power supply
- Motion/servo control

Package

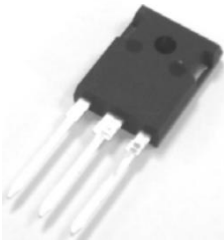

TO-247AB

Marking



Circuit diagram

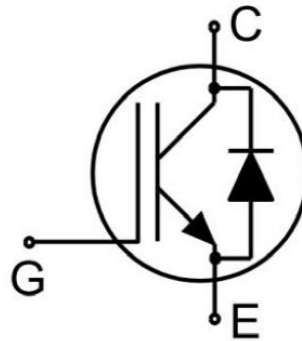

Absolute maximum ratings (Tc=25°C unless otherwise noted)

Parameter	Symbol	Value	Unit
Collector-Emitter Voltage	V _{CES}	650	V
Continuous Gate- Emitter Voltage	V _{GES}	±20	V
Collector Current	I _C	60	A
Collector Current(T _C =100°C)	I _C (100°C)	30	A
Pulsed Collector Current, tp limited by T _{Jmax} , V _{GE} =15V	I _{CM}	120	A
Diode Continuous Forward Current	I _F	60	A
Diode Continuous Forward Current(T _C =100°C)	I _F (100°C)	30	A
Diode Forward Pulsed Current,tp limited by T _{Jmax}	I _{Fpuls}	120	A
Turn off Safe Operating Area V _{CE} ≤650V, T _J ≤150°C	-	120	A
Power Dissipation(T _J =175°C)	P _D	187	W
Thermal Resistance, Junction to case for Diode	R _{θJC}	1.4	°C/W
Thermal Resistance, Junction to case for IGBT	R _{θJC}	0.8	°C/W
Short circuit withstand time V _{GE} =15V, V _{CC} =400V, V _{CEM} ≤650V	t _{sc}	10	us
Maximum Temperature for Soldering,wave soldering 1.6mm (0.063in.) from case for 10s	T _L	260	°C
Junction Temperature Range	T _J	-40 ~ +175	°C
Storage Temperature Range	T _{STG}	-55 ~ +150	°C

Electrical characteristics of the IGBT (T_J=25°C unless otherwise noted)

Parameter	Symbol	Test Condition	Min.	Typ.	Max.	Unit
Static Characteristics						
Collector-Emitter Breakdown Voltage	V _{(BR)CES}	V _{GE} = 0V, I _{CE} =250uA	650			V
Collector-Emitter Leakage Current	I _{CES}	V _{GE} = 0V, V _{CE} =650V			1	mA
		V _{GE} = 0V, V _{CE} =650V, T _J =150°C			5	
Gate to Emitter Leakage Current	I _{GES}	V _{GE} =±20V, V _{CE} = 0V			100	nA
Collector-Emitter Saturation Voltage	V _{CE(sat)}	V _{GE} =15V, I _C =30A		1.85	2.15	V
		V _{GE} =15V, I _C =30A, T _J =125°C		2.15		
		V _{GE} =15V, I _C =30A, T _J =150°C		2.25		
Gate Threshold Voltage	V _{GE(th)}	V _{CE} =V _{GE} , I _C =0.43mA	4.1	5.1	6.1	V
Dynamic characteristics						
Input Capacitance	C _{ies}	V _{CE} =25V, V _{GE} =0V, f =1MHz		1.14		nF
Reverse Transfer Capacitance	C _{res}			0.05		
Total Gate Charge	Q _g	V _{CC} =300V, V _{GE} =15V, I _C =30A		0.15		uC
Short circuit collector current	I _{C(SC)}	V _{GE} =15V, V _{CC} =300V, t _{sc} ≤5us, T _J ≤150°C		150		A
Turn-on delay time	t _{d(on)}	V _{CC} =300V, V _{GE} = -15V~15V, I _C =30A, R _G =15Ω, L _s =60nH		40		nS
Turn-on rise time	t _r			72		
Turn-off delay time	t _{d(off)}			120		
Turn-off fall time	t _f			30		
Turn-on Switching Energy	E _{on}			0.92		
Turn-off Switching Energy	E _{off}		0.40			
Turn-on delay time	t _{d(on)}	V _{CC} =300V, V _{GE} = -15V~15V, I _C =30A, R _G =15Ω, L _s =60nH, T _J =125°C		45		nS
Turn-on rise time	t _r			75		
Turn-off delay time	t _{d(off)}			180		
Turn-off fall time	t _f			35		
Turn-on Switching Energy	E _{on}			1.15		
Turn-off Switching Energy	E _{off}		0.56			
Turn-on delay time	t _{d(on)}	V _{CC} =300V, V _{GE} = -15V~15V, I _C =30A, R _G =15Ω, L _s =60nH, T _J =150°C		48		nS
Turn-on rise time	t _r			78		
Turn-off delay time	t _{d(off)}			195		
Turn-off fall time	t _f			38		
Turn-on Switching Energy	E _{on}			1.35		
Turn-off Switching Energy	E _{off}		0.68			

Electrical characteristics of the Diode ($T_j=25^\circ\text{C}$ unless otherwise noted)

Parameter	Symbol	Test Condition	Min.	Typ.	Max.	Unit
Diode Forward Voltage	V_F	$I_F=30\text{A}$		1.90	2.4	V
		$I_F=30\text{A}, T_j=125^\circ\text{C}$		1.80		
		$I_F=30\text{A}, T_j=150^\circ\text{C}$		1.75		
Reverse Recovery Current	I_{rr}	$I_F=30\text{A}, V_R=300\text{V}, -di/dt=300\text{A}/\mu\text{s}$		6.0		A
Reverse Recovery Charge	Q_{rr}			0.1		μC
Reverse recovery Energy	E_{rec}			0.06		mJ
Reverse Recovery Current	I_{rr}	$I_F=30\text{A}, V_R=300\text{V}, -di/dt=300\text{A}/\mu\text{s}, T_j=125^\circ\text{C}$		10		A
Reverse Recovery Charge	Q_{rr}			0.22		μC
Reverse recovery Energy	E_{rec}			0.09		mJ
Reverse Recovery Current	I_{rr}	$I_F=30\text{A}, V_R=300\text{V}, -di/dt=300\text{A}/\mu\text{s}, T_j=150^\circ\text{C}$		12		A
Reverse Recovery Charge	Q_{rr}			0.26		μC
Reverse recovery Energy	E_{rec}			0.13		mJ

Typical Characteristics

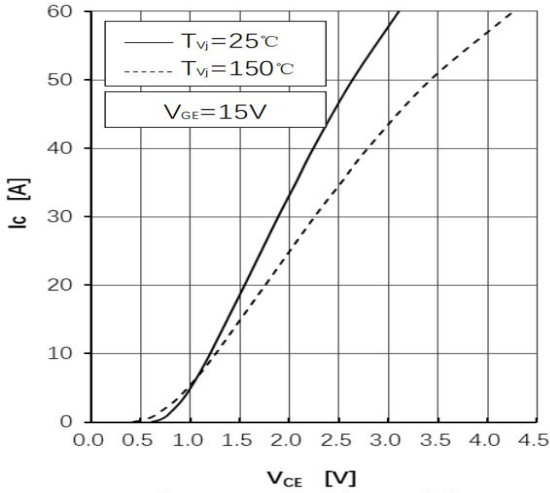

Fig1.IGBT Output Characteristics

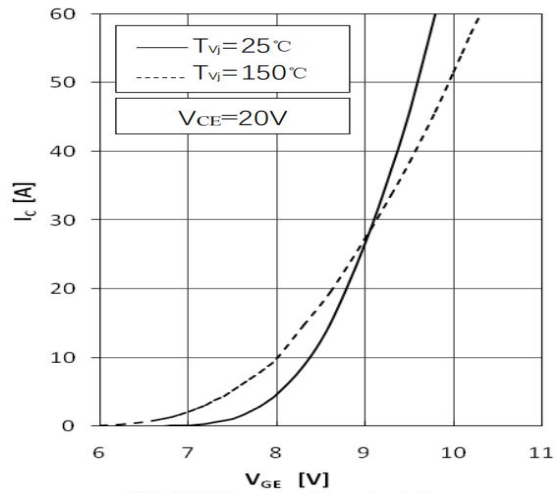

Fig2.IGBT Transfer Characteristics

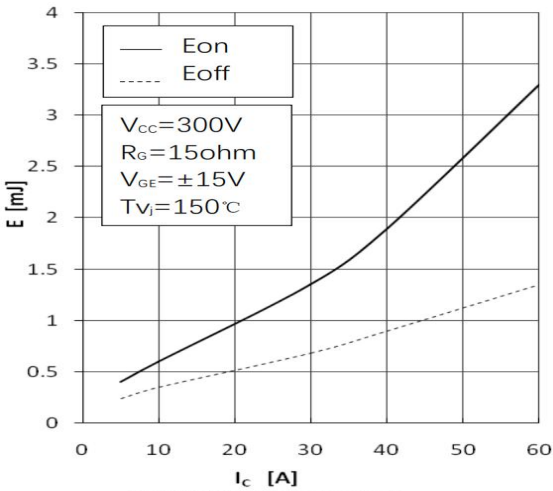

Fig3.IGBT Switching Loss vs.Ic

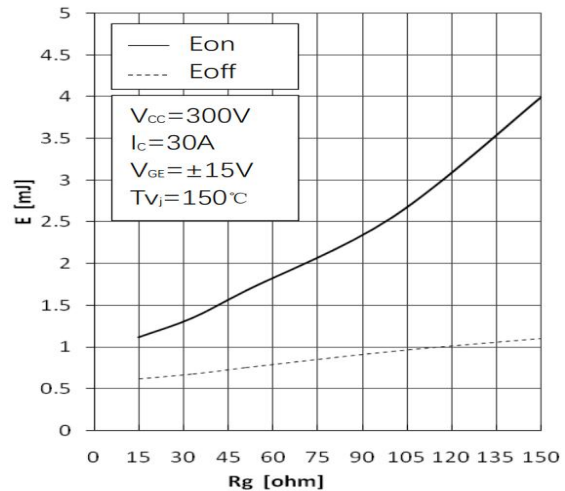

Fig4.IGBT Switching Loss vs.Rg

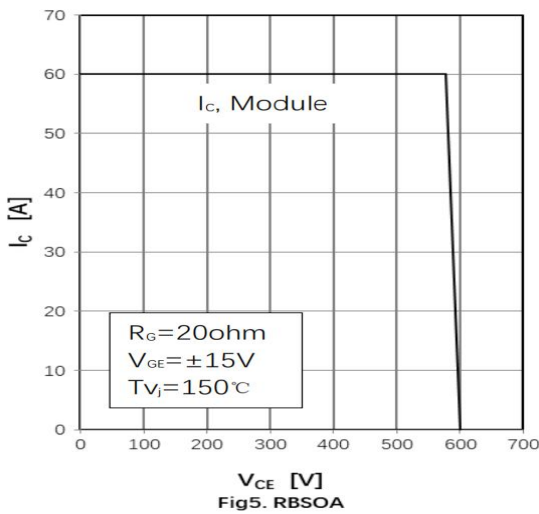

Fig5. RBSOA

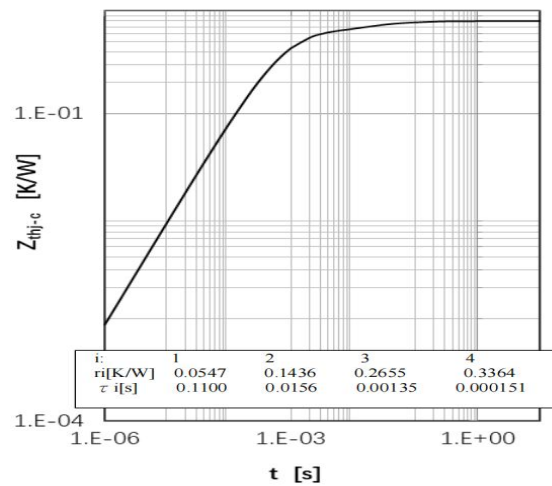

Fig 6. IGBT Transient Thermal Impedance

Typical Characteristics

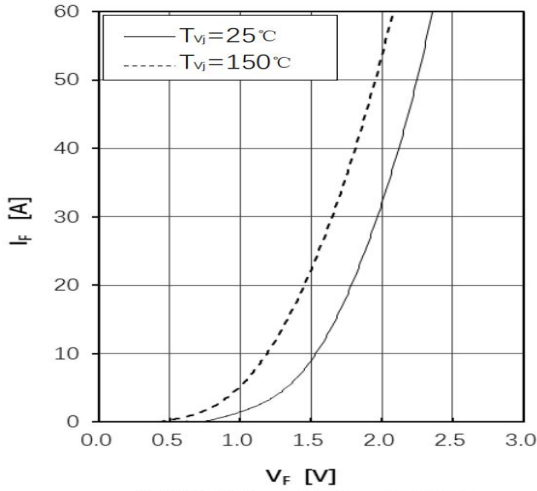

Fig7. Diode Forward Characteristics

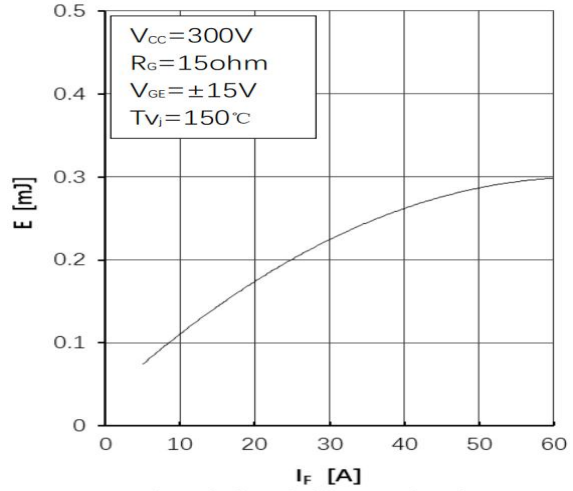

Fig8. Diode Switching Loss(E_{rec}) vs. I_F

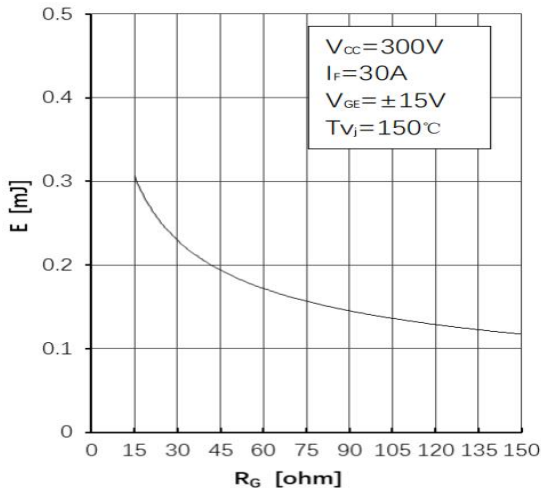

Fig9. Diode Switching Loss(E_{rec}) vs. R_G

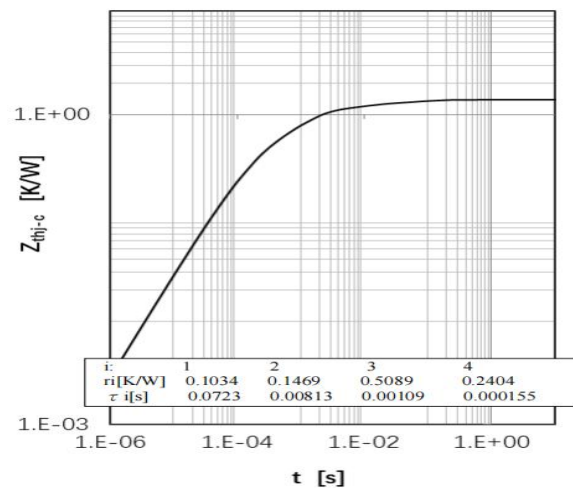
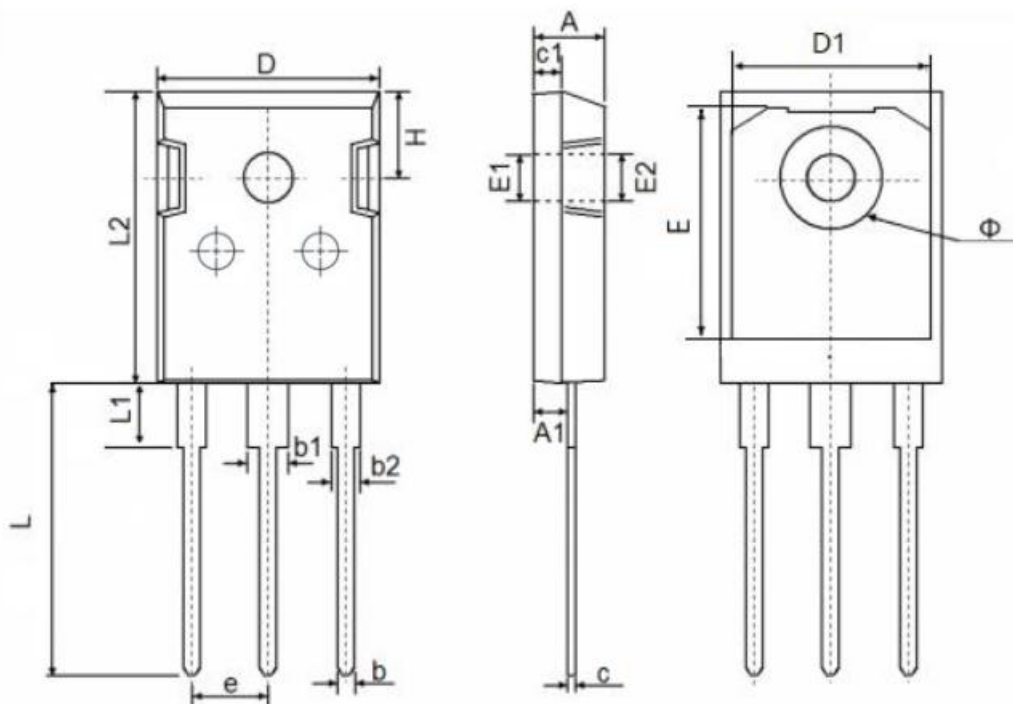

Fig 10. Diode Transient Thermal Impedance

TO-247AB Package Information



Symbol	Dimensions In Millimeters		Dimensions In Inches	
	Min.	Max.	Min.	Max.
A	4.800	5.250	0.189	0.207
A1	2.100	2.600	0.083	0.102
b	1.000	1.400	0.039	0.055
b1	2.800	3.400	0.110	0.134
b2	1.800	2.420	0.071	0.095
c	0.500	0.700	0.020	0.028
c1	1.500	2.500	0.059	0.098
D	15.500	16.200	0.610	0.638
D1	13.000	14.200	0.512	0.559
E	16.250	17.650	0.640	0.695
E1	3.650	5.500	0.144	0.220
E2	3.650	5.500	0.144	0.220
L	19.400	20.400	0.764	0.803
L1	3.900	4.500	0.154	0.177
L2	20.800	21.300	0.819	0.836
φ	7.190 REF.		0.283 REF.	
e	5.440 BSC		0.214 BSC	
H	5.300	6.300	0.209	0.248