

Product Summary

$V_{(BR)CES}$	$V_{CE(SAT)MAX}$	I_c
650V	1.7V@15V	50A

Feature

- High speed smooth switching device for hard & soft switching
- Positive temperature coefficient
- High ruggedness, temperature stable

Application

- Solar converters
- Welding converters
- Mid to high range switching frequency converters
- Uninterruptible power supply

Package

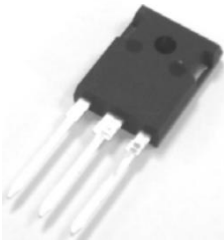

TO-247AB

Marking



Circuit diagram

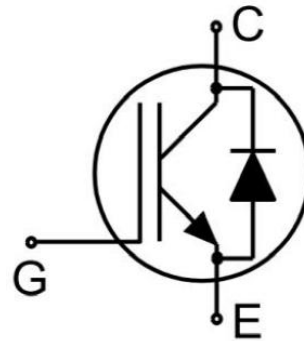

Absolute maximum ratings (Tc=25°C unless otherwise noted)

Parameter	Symbol	Value	Unit
Collector-Emitter Voltage	V _{CEs}	650	V
Continuous Gate- Emitter Voltage	V _{GES}	±20	V
Collector Current	I _c	80	A
Collector Current(T _C =100°C)	I _c (100°C)	60	A
Pulsed Collector Current, tp limited by T _{jmax} ,V _{GE} =15V	I _{CM}	200	A
Diode Continuous Forward Current	I _F	80	A
Diode Continuous Forward Current(T _C =100°C)	I _F (100°C)	60	A
Diode Forward Pulsed Current,tp limited by T _{jmax}	I _{Fpuls}	200	A
Turn off Safe Operating Area V _{CE} ≤650V,T _J ≤150°C	-	200	A
Power Dissipation(T _J =175°C)	P _D	283	W
Thermal Resistance, Junction to case for Diode	R _{θJC}	1.05	°C/W
Thermal Resistance, Junction to case for IGBT	R _{θJC}	0.53	°C/W
Maximum Temperature for Soldering,wave soldering 1.6mm (0.063in.) from case for 10s	T _L	260	°C
Junction Temperature Range	T _J	-40 ~ +175	°C
Storage Temperature Range	T _{STG}	-55 ~ +150	°C

Electrical characteristics of the IGBT (T_J=25°C unless otherwise noted)

Parameter	Symbol	Test Condition	Min.	Typ.	Max.	Unit	
Static Characteristics							
Collector-Emitter Breakdown Voltage	V _{(BR)CES}	V _{GE} = 0V, I _{CE} =250uA	650			V	
Collector-Emitter Leakage Current	I _{CES}	V _{GE} = 0V, V _{CE} =650V			0.25	mA	
		V _{GE} = 0V, V _{CE} =650V, T _J =150°C			3		
Gate to Emitter Leakage Current	I _{GES}	V _{GE} =±20V, V _{CE} = 0V			100	nA	
Collector-Emitter Saturation Voltage	V _{CE(sat)}	V _{GE} =15V, I _C =50A	1.1	1.4	1.7	V	
		V _{GE} =15V, I _C =50A, T _J =125°C		1.6			
		V _{GE} =15V, I _C =50A, T _J =150°C		1.7			
Gate Threshold Voltage	V _{GE(th)}	V _{CE} =V _{GE} , I _C =0.5mA	3.8	4.8	5.8	V	
Dynamic characteristics							
Input Capacitance	C _{ies}	V _{CE} =25V, V _{GE} =0V, f =1MHz		2.86		nF	
Reverse Transfer Capacitance	C _{res}			0.02		nF	
Total Gate Charge	Q _g	V _{CC} =520V, V _{GE} =15V, I _C =50A		0.14		uC	
Turn-on delay time	t _{d(on)}	V _{CC} =400V, V _{GE} = -5V~15V, I _C =50A, R _G =10Ω, Inductive Load		23		nS	
Turn-on rise time	t _r			31			
Turn-off delay time	t _{d(off)}			83			
Turn-off fall time	t _f			49			
Turn-On Switching energy	E _{on}				1.89		mJ
Turn-Off Switching energy	E _{off}				0.55		
Total Switching energy	E _{ts}				2.44		
Turn-on delay time	t _{d(on)}		V _{CC} =400V, V _{GE} = -5V~15V, I _C =50A, R _G =10Ω, Inductive Load, T _J =125°C		24		nS
Turn-on rise time	t _r				38		
Turn-off delay time	t _{d(off)}				90		
Turn-off fall time	t _f			62			
Turn-On Switching energy	E _{on}				1.93		mJ
Turn-Off Switching energy	E _{off}				0.76		
Total Switching energy	E _{ts}				2.69		
Turn-on delay time	t _{d(on)}	V _{CC} =400V, V _{GE} = -5V~15V, I _C =50A, R _G =10Ω, Inductive Load, T _J =150°C			25		nS
Turn-on rise time	t _r				42		
Turn-off delay time	t _{d(off)}				95		
Turn-off fall time	t _f			70			
Turn-On Switching energy	E _{on}				1.99		mJ
Turn-Off Switching energy	E _{off}				0.81		
Total Switching energy	E _{ts}				2.80		

Electrical characteristics of the Diode ($T_j=25^\circ\text{C}$ unless otherwise noted)

Parameter	Symbol	Test Condition	Min.	Typ.	Max.	Unit
Diode Forward Voltage	V_{FM}	$I_F=50\text{A}$		1.60	2.00	V
		$I_F=50\text{A}, T_j=125^\circ\text{C}$		1.50		
		$I_F=50\text{A}, T_j=150^\circ\text{C}$		1.40		
Reverse Recovery Current	I_{rr}	$I_F=50\text{A}, V_R=400\text{V}, -di/dt=450\text{A}/\mu\text{s}$		15		A
Diode reverse recovery time	t_{rr}			148		ns
Reverse Recovery Charge	Q_{rr}			1.58		μC
Reverse recovery energy	E_{rec}			0.29		mJ
Reverse Recovery Current	I_{rr}	$I_F=50\text{A}, V_R=400\text{V}, -di/dt=450\text{A}/\mu\text{s}, T_j=125^\circ\text{C}$		21		A
Diode reverse recovery time	t_{rr}			183		ns
Reverse Recovery Charge	Q_{rr}			2.54		μC
Reverse recovery energy	E_{rec}			0.65		mJ
Reverse Recovery Current	I_{rr}	$I_F=50\text{A}, V_R=400\text{V}, -di/dt=450\text{A}/\mu\text{s}, T_j=150^\circ\text{C}$		24		A
Diode reverse recovery time	t_{rr}			218		ns
Reverse Recovery Charge	Q_{rr}			3.59		μC
Reverse recovery energy	E_{rec}			0.79		mJ

Typical Characteristics

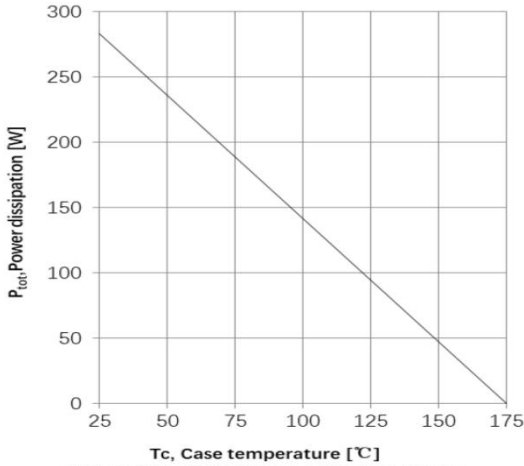

Fig1. Power dissipation as a function of case temperature ($T_j \leq 175^\circ\text{C}$)

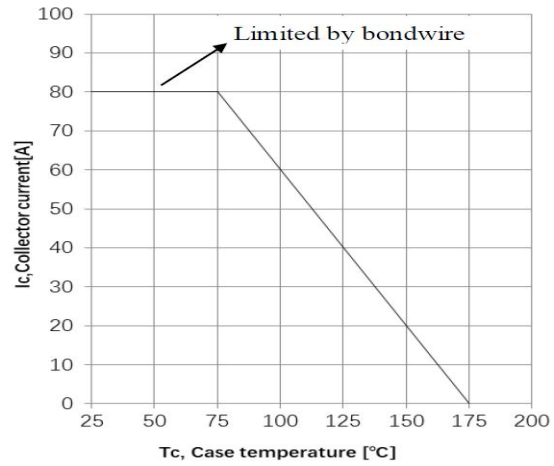

Fig2. Collector current as a function of case temperature ($V_{ge} \geq 15\text{V}$, $T_j \leq 175^\circ\text{C}$)

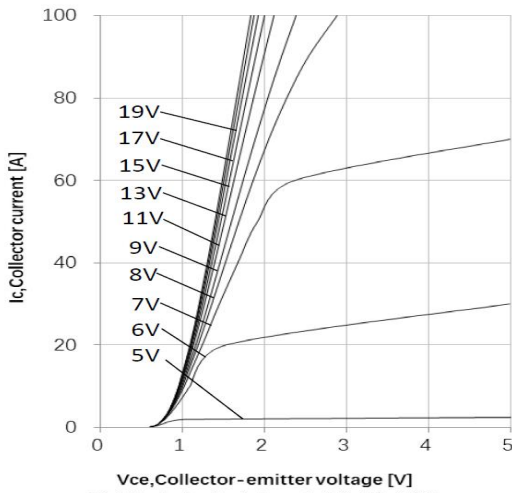

Fig3. Typical output characteristic ($T_j = 25^\circ\text{C}$)

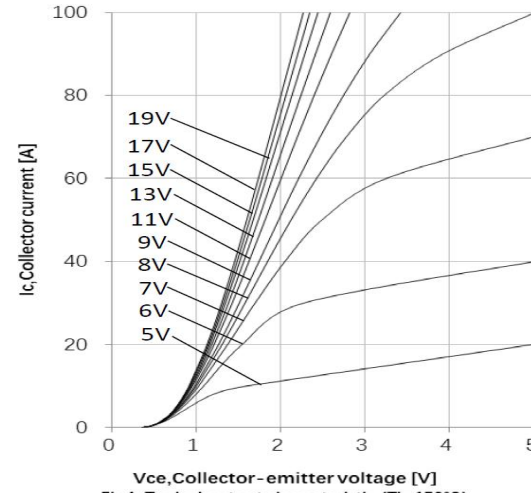

Fig4. Typical output characteristic ($T_j = 150^\circ\text{C}$)

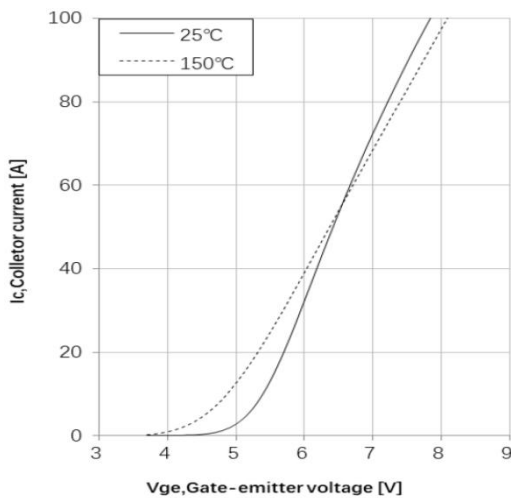

Fig5. Typical transfer characteristic ($V_{ce} = 20\text{V}$)

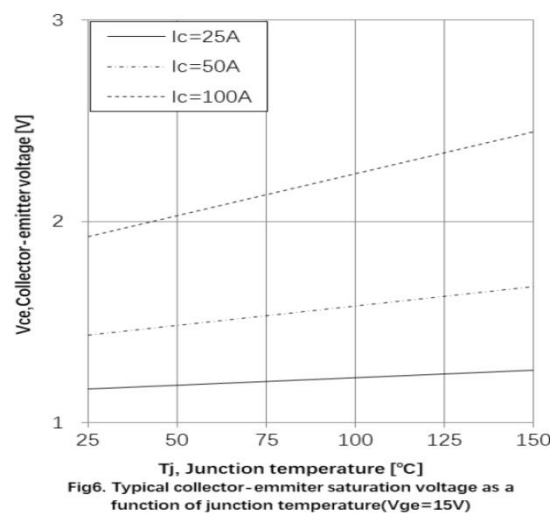
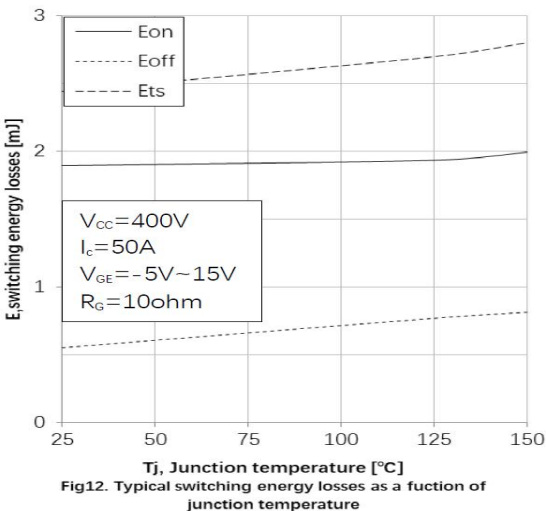
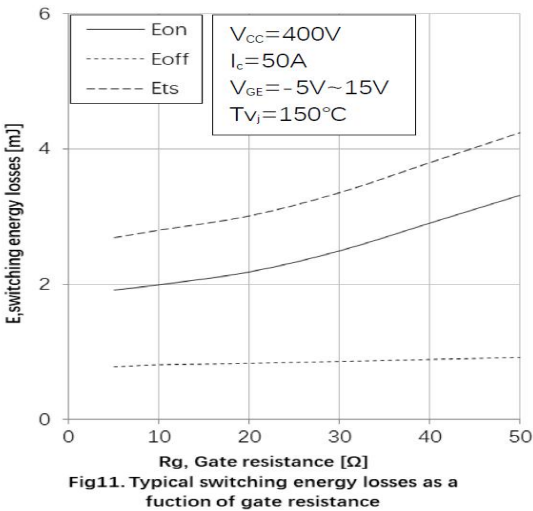
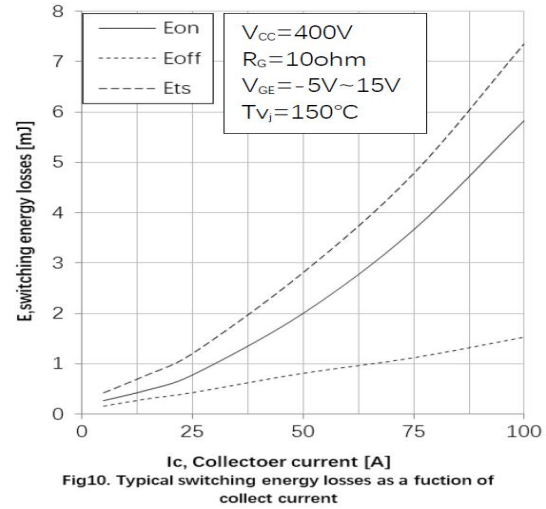
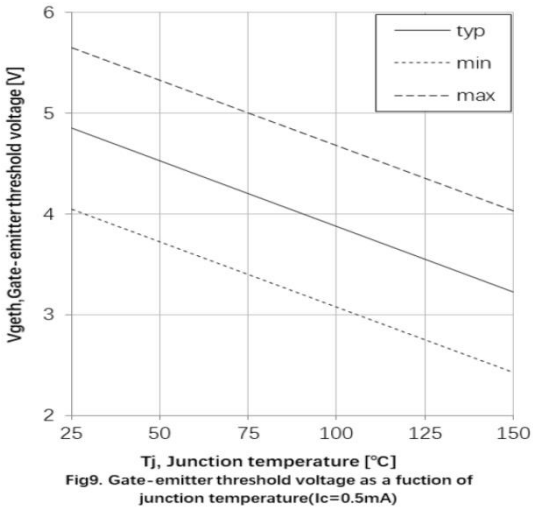
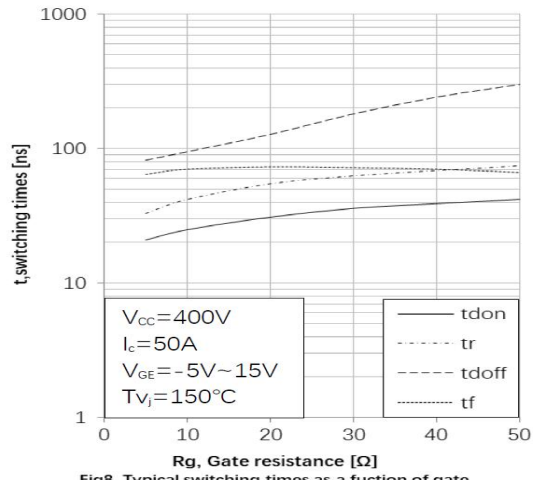
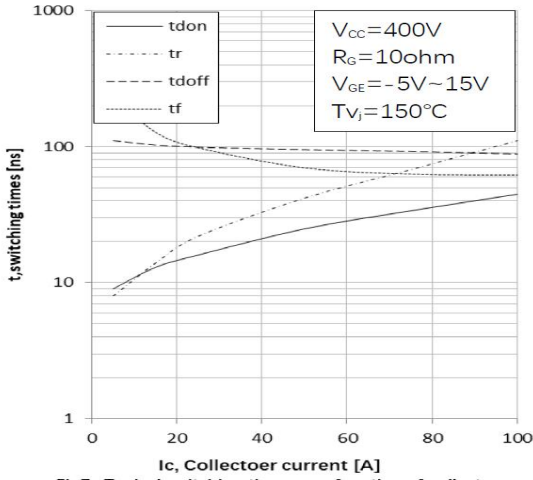

Fig6. Typical collector-emitter saturation voltage as a function of junction temperature ($V_{ge} = 15\text{V}$)

Typical Characteristics



Typical Characteristics

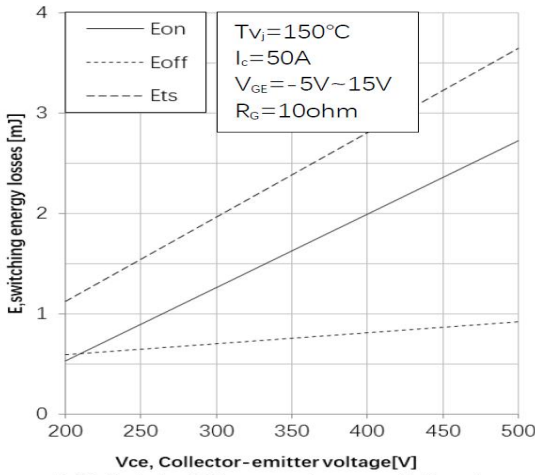

Fig13. Typical switching energy losses as a function of collector-emitter voltage

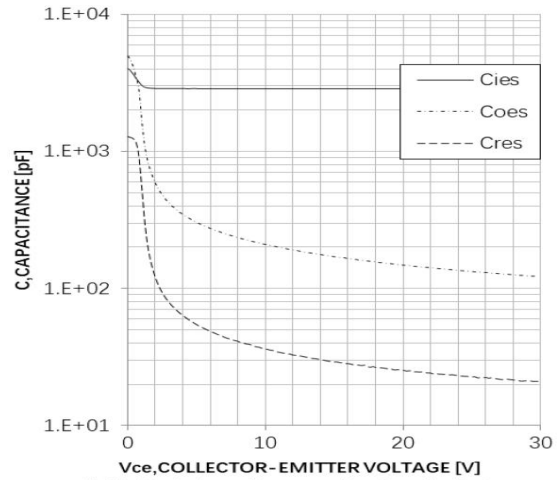

Fig14. Typical capacitance as a function of collector-emitter voltage

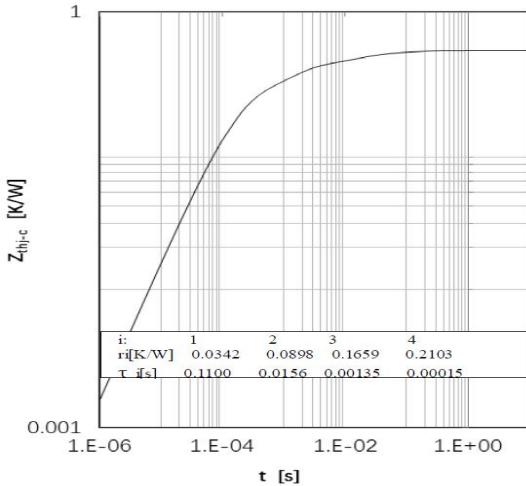

Fig 15. IGBT Transient Thermal Impedance

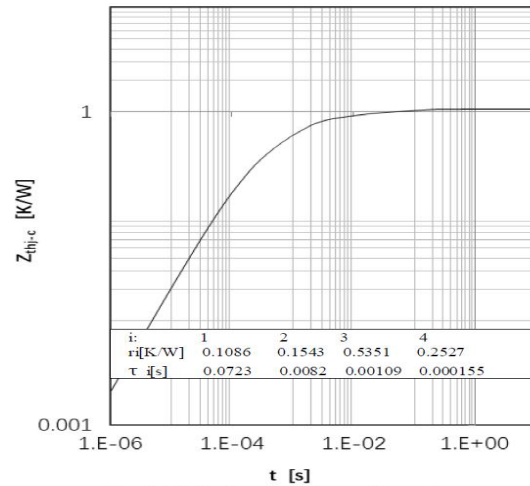

Fig 16. Diode Transient Thermal Impedance

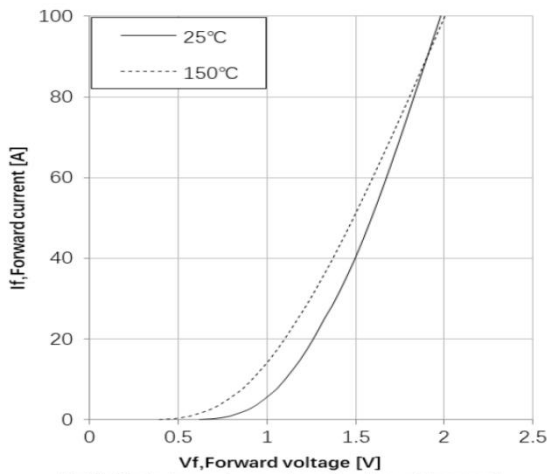

Fig17. Diode forward current as a function of forward voltage

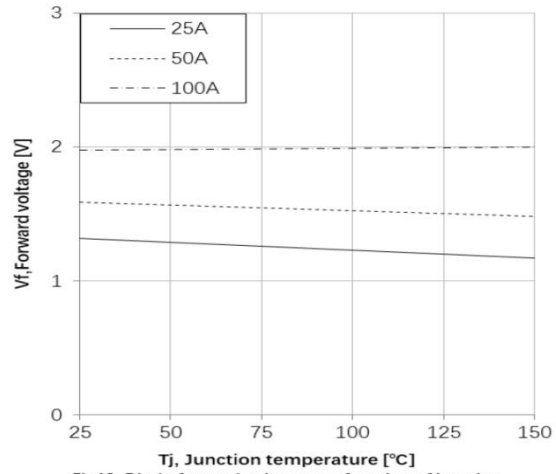
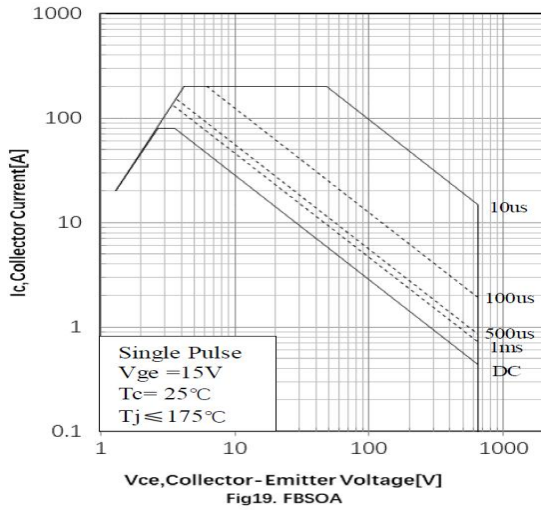
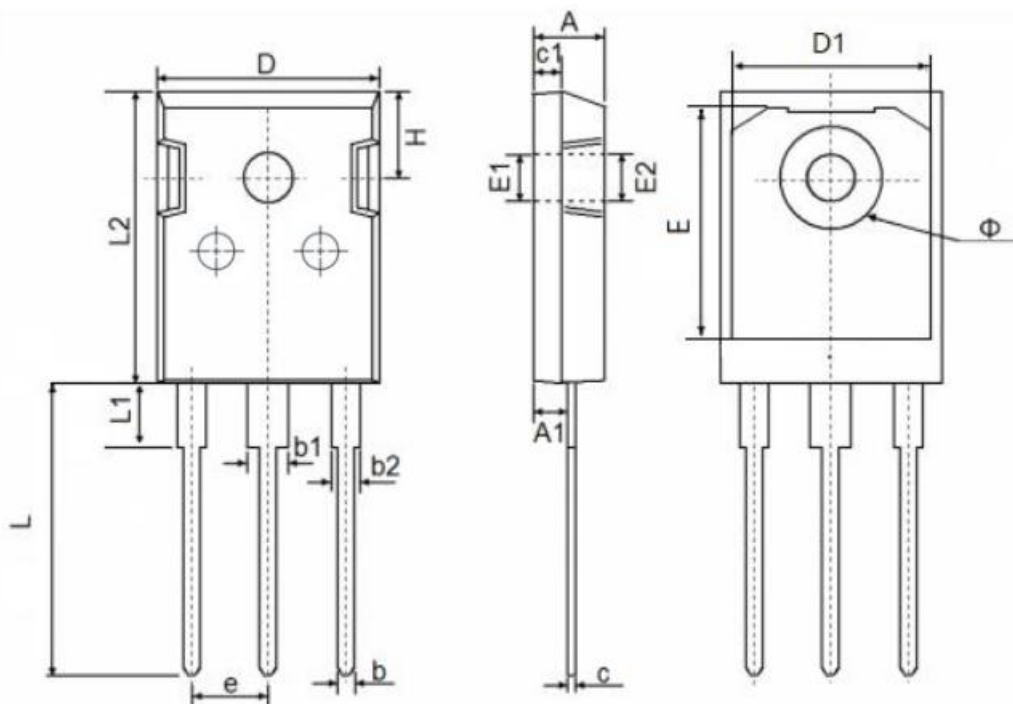

Fig18. Diode forward voltage as a function of junction temperature

Typical Characteristics



TO-247AB Package Information



Symbol	Dimensions In Millimeters		Dimensions In Inches	
	Min.	Max.	Min.	Max.
A	4.800	5.250	0.189	0.207
A1	2.100	2.600	0.083	0.102
b	1.000	1.400	0.039	0.055
b1	2.800	3.400	0.110	0.134
b2	1.800	2.420	0.071	0.095
c	0.500	0.700	0.020	0.028
c1	1.500	2.500	0.059	0.098
D	15.500	16.200	0.610	0.638
D1	13.000	14.200	0.512	0.559
E	16.250	17.650	0.640	0.695
E1	3.650	5.500	0.144	0.220
E2	3.650	5.500	0.144	0.220
L	19.400	20.400	0.764	0.803
L1	3.900	4.500	0.154	0.177
L2	20.800	21.300	0.819	0.836
φ	7.190 REF.		0.283 REF.	
e	5.440 BSC		0.214 BSC	
H	5.300	6.300	0.209	0.248