

Product Summary

$V_{(BR)CES}$	$V_{CE(SAT)MAX}$	$I_c(100^\circ C)$
650V	2.4V@15V	60A

Feature

- Low switching losses
- Positive temperature coefficient
- High ruggedness, temperature stable
- High short circuit capability

Application

- High frequency switching application
- Medical applications
- Uninterruptible power supply
- Motion/servo control

Package

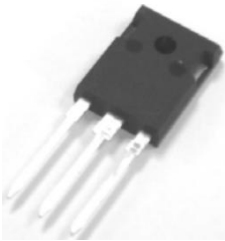

TO-247AB

Marking



Circuit diagram

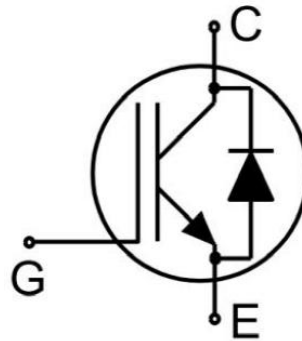

Absolute maximum ratings (Tc=25°C unless otherwise noted)

Parameter	Symbol	Value	Unit
Collector-Emitter Voltage	V _{CES}	650	V
Continuous Gate- Emitter Voltage	V _{GES}	±20	V
Collector Current	I _C	120	A
Collector Current(T _C =100°C)	I _C (100°C)	60	A
Pulsed Collector Current, tp limited by Tjmax,V _{GE} =15V	I _{CM}	240	A
Diode Continuous Forward Current	I _F	60	A
Diode Continuous Forward Current(T _C =100°C)	I _F (100°C)	30	A
Diode Forward Pulsed Current,tp limited by Tjmax	I _{Fpuls}	120	A
Turn off Safe Operating Area V _{CE} ≤650V,T _J ≤150°C	-	240	A
Power Dissipation(T _J =175°C)	P _D	333	W
Thermal Resistance, Junction to case for Diode	R _{θJC}	1.05	°C/W
Thermal Resistance, Junction to case for IGBT	R _{θJC}	0.45	°C/W
Short circuit withstand time V _{GE} =15V, V _{CC} =400V, V _{CEM} ≤650V	t _{sc}	5	us
Maximum Temperature for Soldering,wave soldering 1.6mm (0.063in.) from case for 10s	T _L	260	°C
Junction Temperature Range	T _J	-40 ~ +175	°C
Storage Temperature Range	T _{STG}	-55 ~ +150	°C

Electrical characteristics of the IGBT (T_J=25°C unless otherwise noted)

Parameter	Symbol	Test Condition	Min.	Typ.	Max.	Unit
Static Characteristics						
Collector-Emitter Breakdown Voltage	V _{(BR)CES}	V _{GE} = 0V, I _{CE} =250uA	650			V
Collector-Emitter Leakage Current	I _{CES}	V _{GE} = 0V, V _{CE} =650V			0.25	mA
		V _{GE} = 0V, V _{CE} =650V, T _J =150°C			4	
Gate to Emitter Leakage Current	I _{GES}	V _{GE} =±20V, V _{CE} = 0V			100	nA
Collector-Emitter Saturation Voltage	V _{CE(sat)}	V _{GE} =15V, I _C =60A		2.10	2.40	V
		V _{GE} =15V, I _C =60A, T _J =125°C		2.40		
		V _{GE} =15V, I _C =60A, T _J =150°C		2.50		
Gate Threshold Voltage	V _{GE(th)}	V _{CE} =V _{GE} , I _C =0.8mA	4.1	5.1	6.1	V
Dynamic characteristics						
Input Capacitance	C _{ies}	V _{CE} =25V, V _{GE} =0V, f =1MHz		2.04		nF
Reverse Transfer Capacitance	C _{res}			0.84		
Total Gate Charge	Q _g	V _{CC} =300V, V _{GE} =15V, I _C =60A		0.24		uC
Short circuit collector current	I _{C(SC)}	V _{GE} =15V, V _{CC} =400V, t _{sc} ≤5us, T _J ≤150°C		280		A
Turn-on delay time	t _{d(on)}	V _{CC} =400V, V _{GE} = 0V~15V, I _C =60A, R _G =10Ω, L _s =60nH		18		nS
Turn-on rise time	t _r			75		
Turn-off delay time	t _{d(off)}			163		
Turn-off fall time	t _f			62		
Turn-on Switching Energy	E _{on}			2.84		
Turn-off Switching Energy	E _{off}		1.21			
Turn-on delay time	t _{d(on)}	V _{CC} =400V, V _{GE} = 0V~15V, I _C =60A, R _G =10Ω, L _s =60nH, T _J =125°C		17		nS
Turn-on rise time	t _r			65		
Turn-off delay time	t _{d(off)}			176		
Turn-off fall time	t _f			70		
Turn-on Switching Energy	E _{on}			2.86		
Turn-off Switching Energy	E _{off}		1.41			
Turn-on delay time	t _{d(on)}	V _{CC} =400V, V _{GE} = 0V~15V, I _C =60A, R _G =10Ω, L _s =60nH, T _J =150°C		16		nS
Turn-on rise time	t _r			59		
Turn-off delay time	t _{d(off)}			182		
Turn-off fall time	t _f			82		
Turn-on Switching Energy	E _{on}			2.98		
Turn-off Switching Energy	E _{off}		1.51			

Electrical characteristics of the Diode ($T_j=25^\circ\text{C}$ unless otherwise noted)

Parameter	Symbol	Test Condition	Min.	Typ.	Max.	Unit
Diode Forward Voltage	V_F	$I_F=30\text{A}$		1.90	2.60	V
		$I_F=30\text{A}, T_j=125^\circ\text{C}$		1.85		
		$I_F=30\text{A}, T_j=150^\circ\text{C}$		1.75		
Reverse Recovery Current	I_{rr}	$I_F=30\text{A}, V_R=400\text{V}, -di/dt=350\text{A/us}$		7		A
Reverse Recovery Charge	Q_{rr}			0.14		μC
Diode reverse recovery time	t_{rr}			42		ns
Reverse recovery energy	E_{rec}			0.09		mJ
Reverse Recovery Current	I_{rr}	$I_F=30\text{A}, V_R=400\text{V}, -di/dt=350\text{A/us}, T_j=125^\circ\text{C}$		13		A
Reverse Recovery Charge	Q_{rr}			0.94		μC
Diode reverse recovery time	t_r			153		ns
Reverse recovery energy	E_{rec}			0.22		mJ
Reverse Recovery Current	I_{rr}	$I_F=30\text{A}, V_R=400\text{V}, -di/dt=350\text{A/us}, T_j=150^\circ\text{C}$		15		A
Reverse Recovery Charge	Q_{rr}			1.26		μC
Diode reverse recovery time	t_r			161		ns
Reverse recovery energy	E_{rec}			0.26		mJ

Typical Characteristics

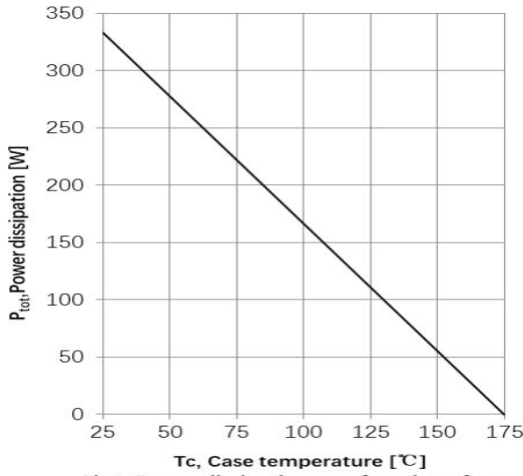

Fig1. Power dissipation as a function of case temperature ($T_j \leq 175^\circ\text{C}$)

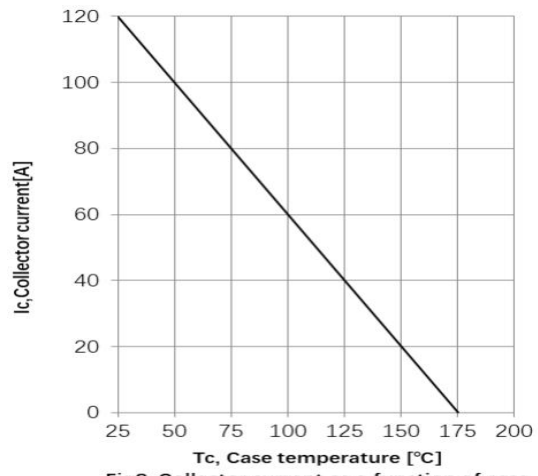

Fig2. Collector current as a function of case temperature ($V_{ge} \geq 15\text{V}$, $T_j \leq 175^\circ\text{C}$)

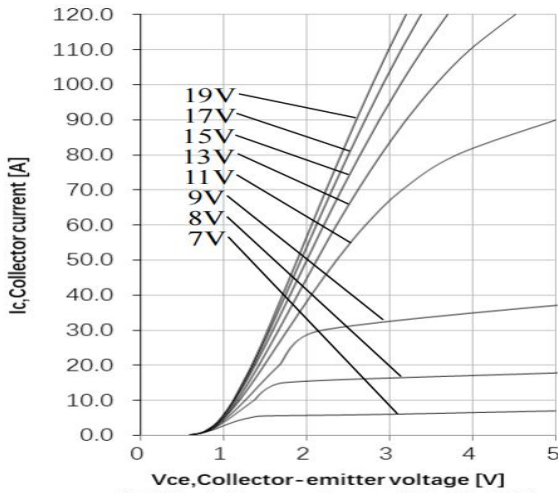

Fig3. Typical output characteristic ($T_j = 25^\circ\text{C}$)

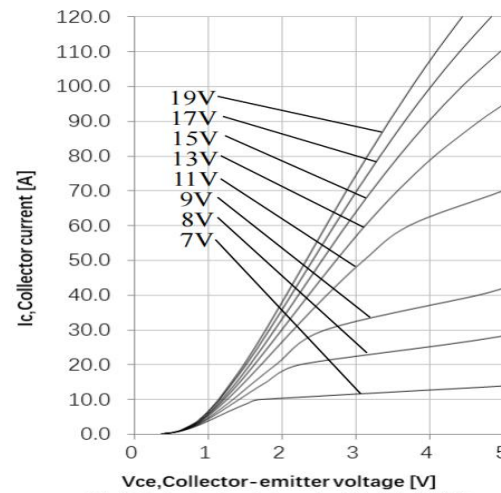

Fig4. Typical output characteristic ($T_j = 150^\circ\text{C}$)

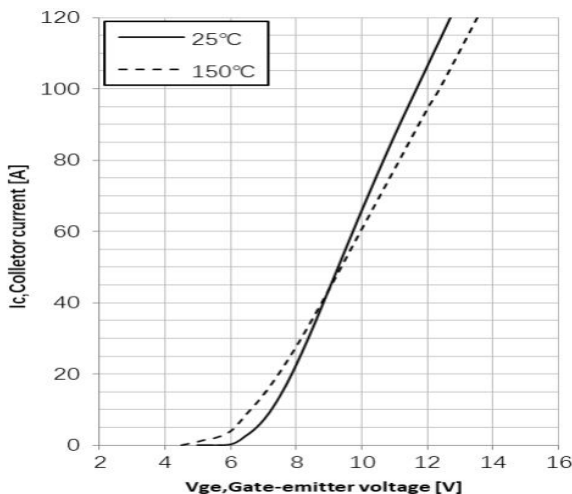

Fig5. Typical transfer characteristic ($V_{ce} = 20\text{V}$)

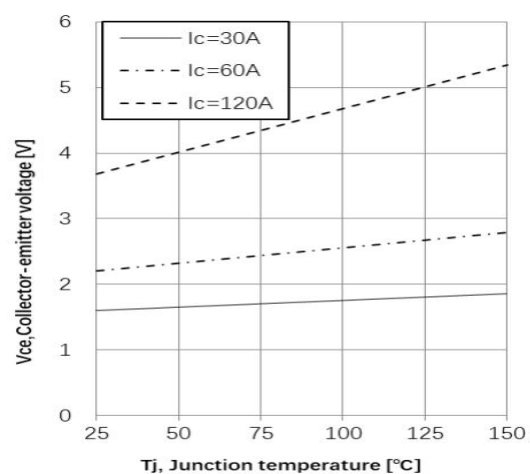

Fig6. Typical collector-emitter saturation voltage as a function of junction temperature ($V_{ge} = 15\text{V}$)

Typical Characteristics

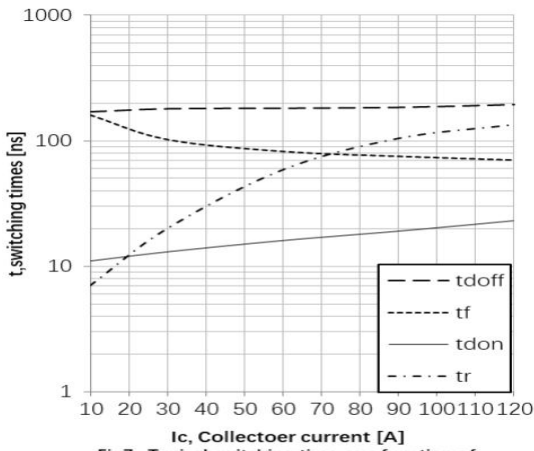

Fig7. Typical switching time as a function of collector current (inductive)
load, $T_{vj}=150^{\circ}\text{C}$, $V_{ce}=400\text{V}$, $V_{ge}=0/15\text{V}$, $R_g=10\Omega$

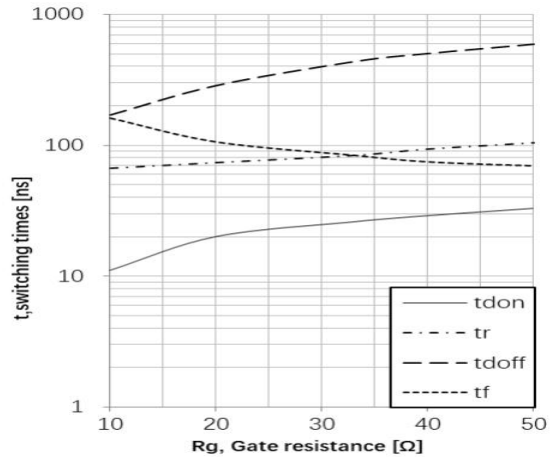

Fig8. Typical switching times as a function of gate resistance (inductive)
load, $T_{vj}=150^{\circ}\text{C}$, $V_{ce}=400\text{V}$, $V_{ge}=0/15\text{V}$, $I_c=60\text{A}$

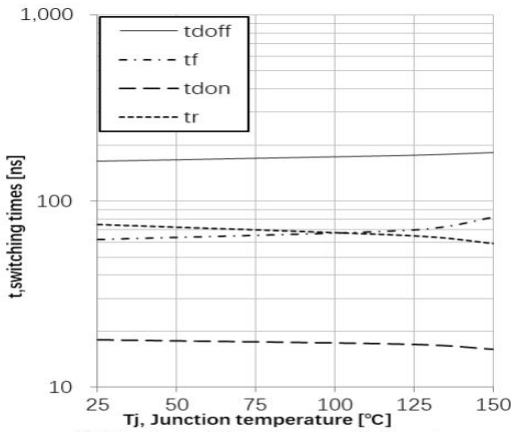

Fig9. Typical switching times as a function of junction temperature (inductive)
load, $I_c=60\text{A}$, $V_{ce}=400\text{V}$, $V_{ge}=0/15\text{V}$, $R_g=10\Omega$

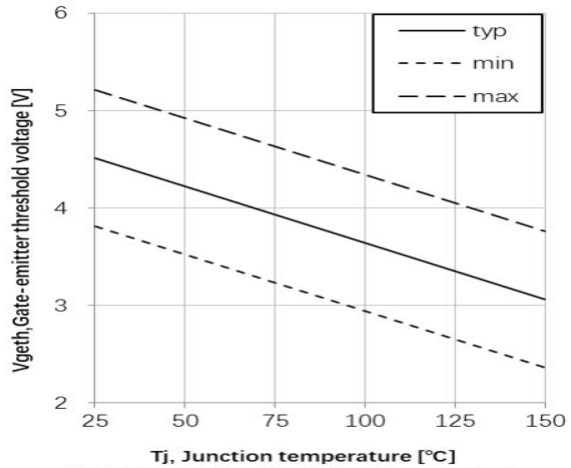

Fig10. Gate-emitter threshold voltage as a function of junction temperature ($I_c=0.8\text{mA}$)

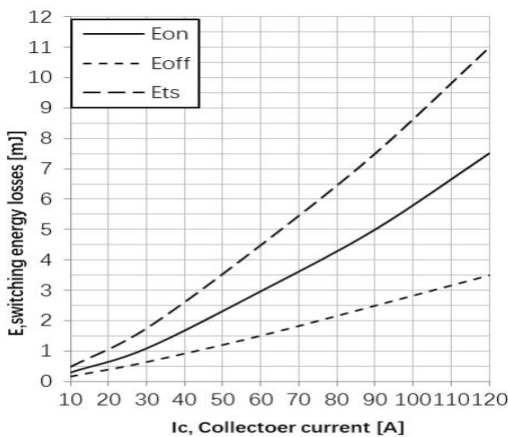

Fig11. Typical switching energy losses as a function of collector current (inductive)
load, $T_{vj}=150^{\circ}\text{C}$, $V_{ce}=400\text{V}$, $V_{ge}=0/15\text{V}$, $R_g=10\Omega$

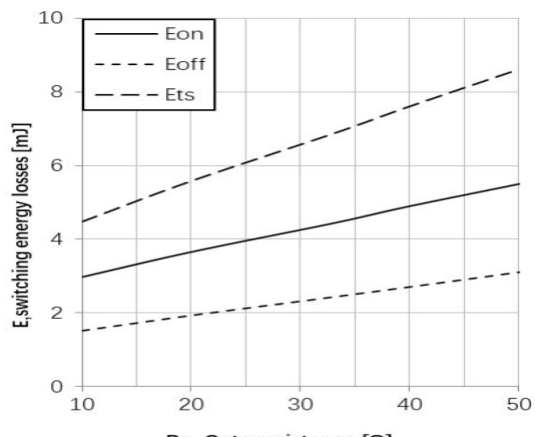

Fig12. Typical switching energy losses as a function of gate resistance (inductive)
load, $T_{vj}=150^{\circ}\text{C}$, $V_{ce}=400\text{V}$, $V_{ge}=0/15\text{V}$, $I_c=60\text{A}$

Typical Characteristics

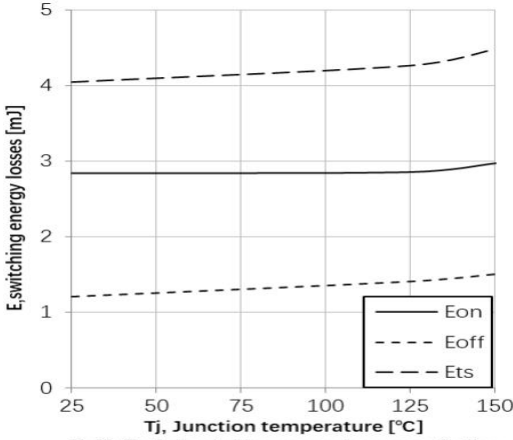

Fig13. Typical switching energy losses as a function of junction temperature (inductive)
load, Ic=60A, Vce=400V, Vge=0/15V, Rg=10Ω

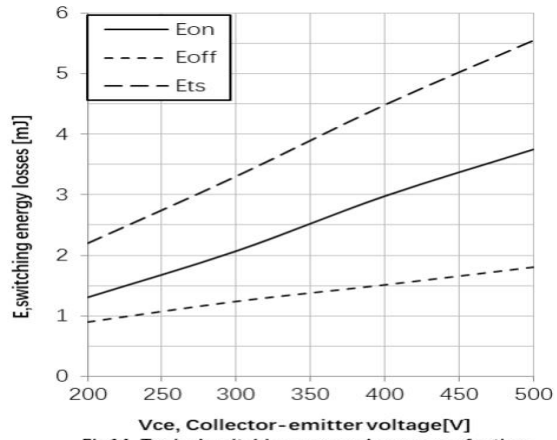

Fig14. Typical switching energy losses as a function of collector-emitter voltage (inductive)
load, Tvj=150°C, Ic=60A, Vge=0/15V, Rg=10Ω

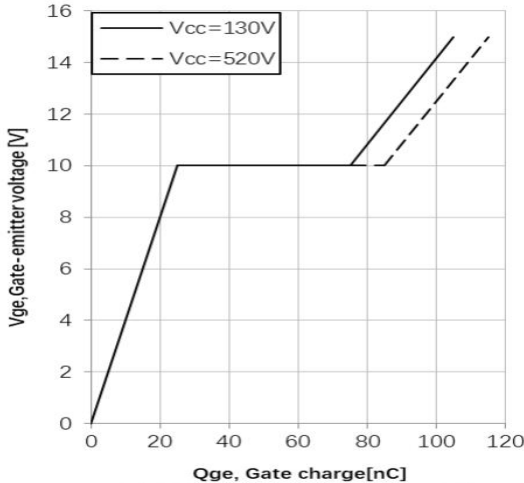

Fig15. Typical gate charge (Ic=60A)

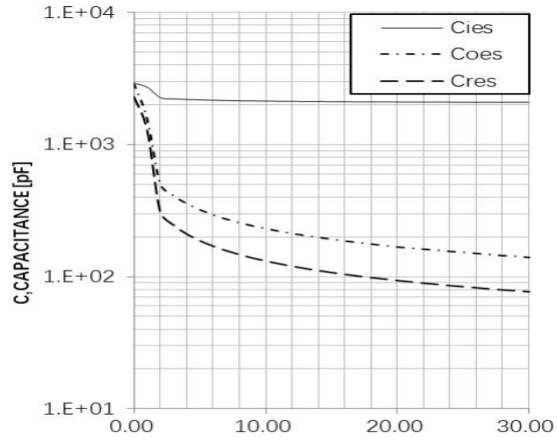

Fig16. Typical capacitance as a function of collector-emitter voltage

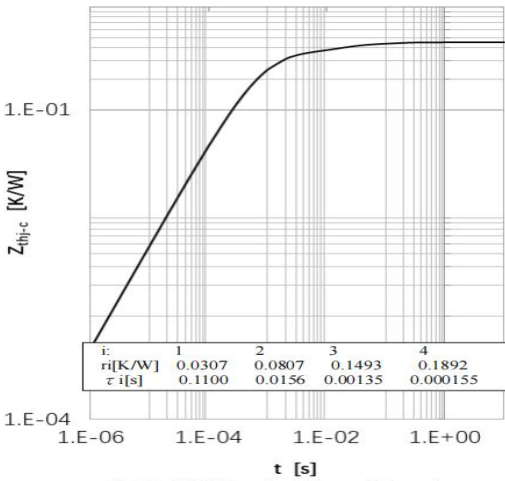

Fig 17. IGBT Transient Thermal Impedance

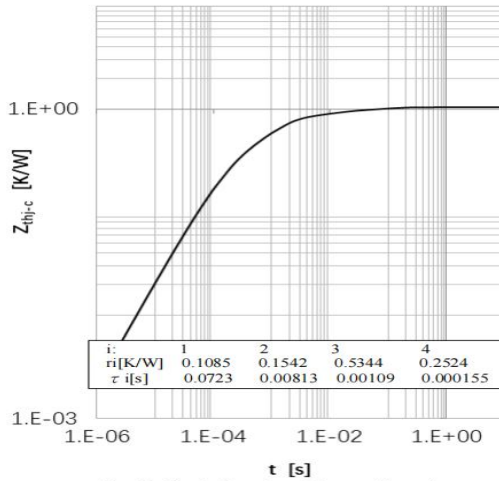

Fig 18. Diode Transient Thermal Impedance

Typical Characteristics

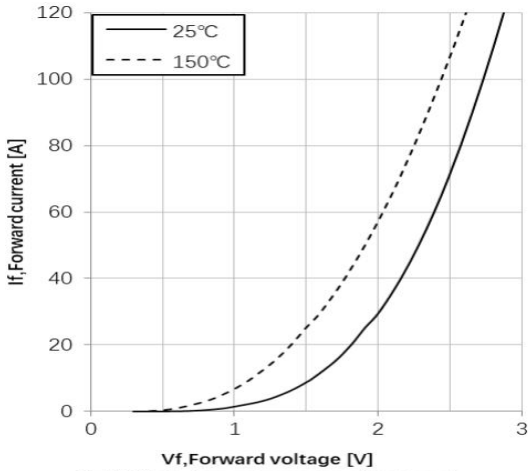

Fig19. Diode forward current as a function of forward voltage

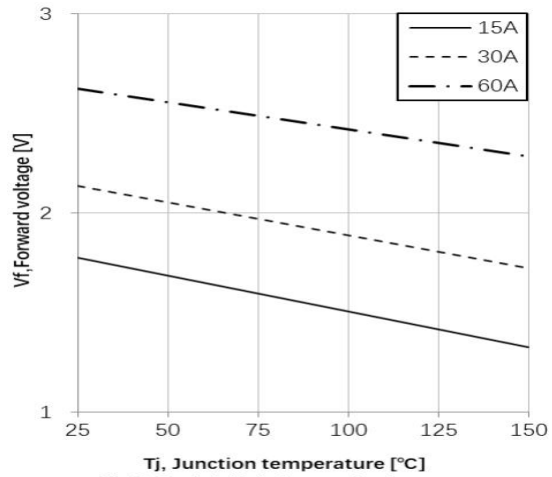

Fig20. Typical diode forward voltage as a function of junction temperature

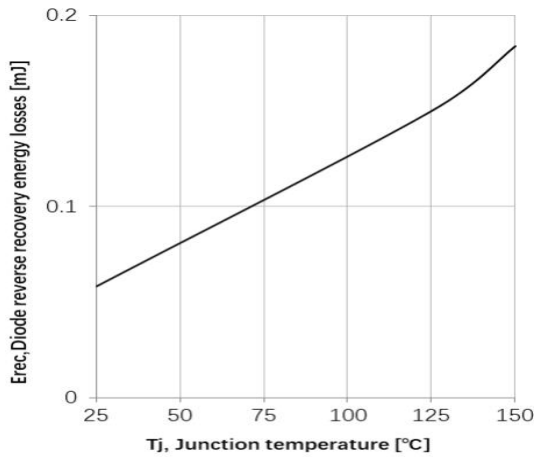

Fig21. Typical diode reverse recovery energy losses as a function of junction temperature (inductive load, $I_f=60A, V_{rr}=400V$)

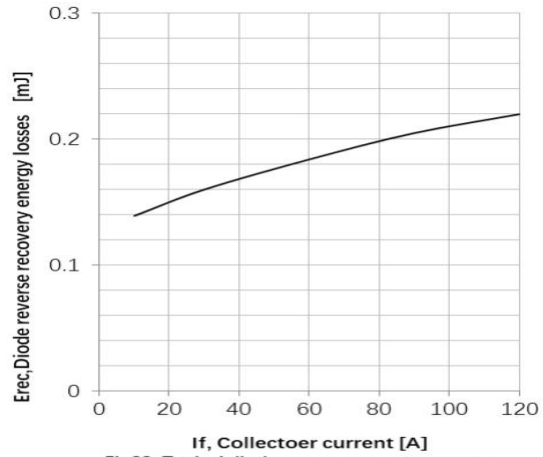
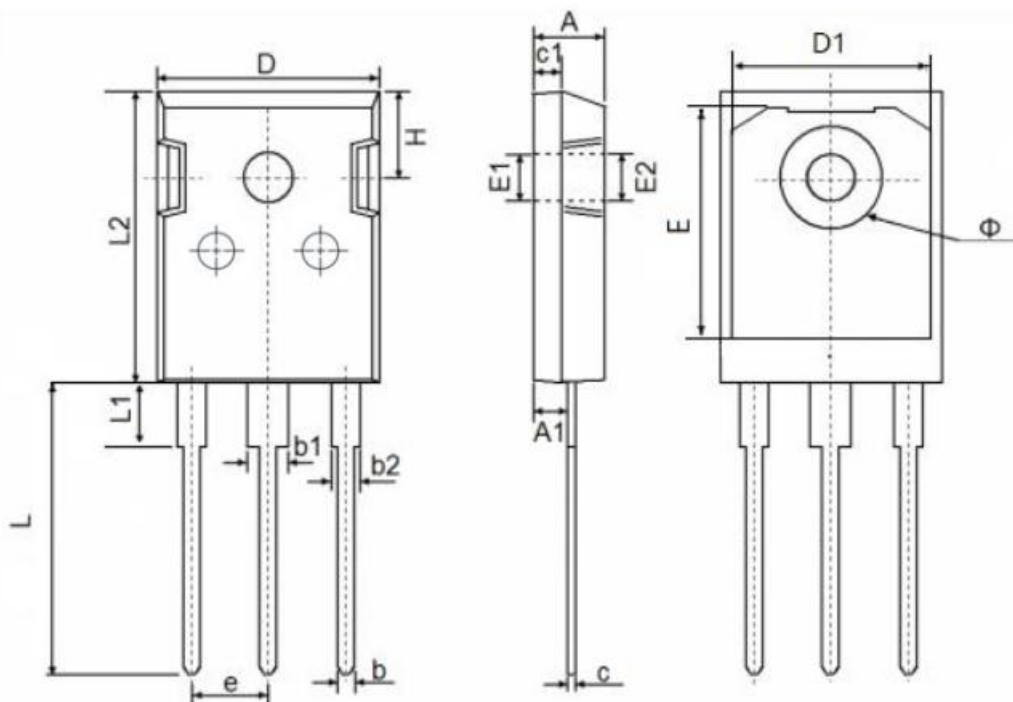

Fig22. Typical diode reverse recovery energy losses as a function of collector current (inductive load, $T_{vj}=150^{\circ}C, V_{rr}=400V$)

TO-247AB Package Information



Symbol	Dimensions In Millimeters		Dimensions In Inches	
	Min.	Max.	Min.	Max.
A	4.800	5.250	0.189	0.207
A1	2.100	2.600	0.083	0.102
b	1.000	1.400	0.039	0.055
b1	2.800	3.400	0.110	0.134
b2	1.800	2.420	0.071	0.095
c	0.500	0.700	0.020	0.028
c1	1.500	2.500	0.059	0.098
D	15.500	16.200	0.610	0.638
D1	13.000	14.200	0.512	0.559
E	16.250	17.650	0.640	0.695
E1	3.650	5.500	0.144	0.220
E2	3.650	5.500	0.144	0.220
L	19.400	20.400	0.764	0.803
L1	3.900	4.500	0.154	0.177
L2	20.800	21.300	0.819	0.836
φ	7.190 REF.		0.283 REF.	
e	5.440 BSC		0.214 BSC	
H	5.300	6.300	0.209	0.248