

Product Summary

$V_{(BR)CES}$	$V_{CE(SAT)MAX}$	$I_c(100^{\circ}C)$
650V	1.7V@15V	15A

Feature

- High speed smooth switching device for hard & soft switching
- Positive temperature coefficient
- High ruggedness, temperature stable

Application

- Soft switching applications
- Air conditioning
- Motor drive inverter

Package

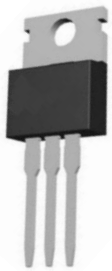

TO-220AB

Circuit diagram

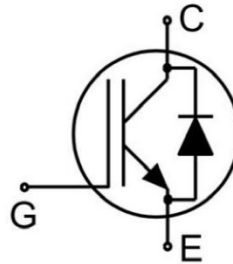

Marking



Absolute maximum ratings (Tc=25°C unless otherwise noted)

Parameter	Symbol	Value	Unit
Collector-Emitter Voltage	V_{CES}	650	V
Continuous Gate-Emitter Voltage	V_{GE}	± 20	V
Transient Gate-Emitter Voltage((tp≤10μs,D<0.01)	V_{GE}	± 30	V
DC Collector Current, limited by T_{jmax}	I_C	30	A
DC Collector Current, limited by $T_{jmax}(T_C = 100^\circ C)$	$I_C(100^\circ C)$	15	A
Diode Forward Current, limited by T_{jmax}	I_F	30	A
Diode Forward Current, limited by $T_{jmax}(T_C = 100^\circ C)$	$I_F(100^\circ C)$	15	A
Turn off Safe Operating Area $V_{CE} \leq 600V, T_j \leq 150^\circ C$		45	A
Pulsed Collector Current, $V_{GE}=15V, tp$ limited by T_{jmax}	I_{CM}	45	A
Short Circuit Withstand Time, $V_{GE}= 15V, V_{CE} \leq 400V$	T_{SC}	5	μs
Diode Pulsed Current, tp limited by T_{jmax}	I_{Fpuls}	45	A
Power Dissipation	P_{tot}	110	W
Thermal Resistance, Junction to case for Diode	$R_{\theta JC}$	1.5	°C/W
Thermal Resistance, Junction to case for IGBT	$R_{\theta JC}$	1.35	°C/W
Soldering Temperature, wave soldering 1.6mm (0.063in.) from case for 10s		260	°C
Junction Temperature	T_J	175	°C
Storage Temperature Range	T_{STG}	-55 ~ +150	°C

Electrical characteristics (Tj=25°C unless otherwise noted)

Parameter	Symbol	Test Condition	Min.	Typ.	Max.	Unit
Static Characteristics						
Collector-Emitter Breakdown Voltage	$V_{(BR)CES}$	$V_{GE} = 0V, I_C = 250\mu A$	650			V
Gate Threshold Voltage	$V_{GE(th)}$	$V_{CE} = V_{GE}, I_C = 1mA$	5.0	5.8	6.5	V
Collector-Emitter Saturation Voltage	$V_{CE(sat)}$	$V_{GE}=15V, I_C=15A$		1.40	1.70	V
		$V_{GE}=15V, I_C=15A, T_j=125^\circ C$		1.55		
		$V_{GE}=15V, I_C=15A, T_j=150^\circ C$		1.60		
Zero Gate Voltage Collector Current	I_{CES}	$V_{CE}=650V, V_{GE}=0V$			0.25	mA
		$V_{CE}=650V, V_{GE}=0V, T_j=150^\circ C$			1.00	
Gate to Emitter Leakage Current	I_{GES}	$V_{CE} = 0V, V_{GE} = \pm 20V$			± 200	nA
Dynamic characteristics						
Input Capacitance	C_{ies}	$V_{CE}=25V, V_{GE}=0V, f=1MHz$		0.88		nF
Output Capacitance	C_{oes}			0.04		
Reverse Transfer Capacitance	C_{res}			0.01		
Gate Charge	Q_g	$V_{CC}=300V, V_{GE} = 15V, I_C=15A$		0.069		μC
Short circuit collector current	$I_{C(SC)}$	$V_{GE}=15V, t_{sc} \leq 5\mu s, V_{CC}=400V, T_{j,start}=25^\circ C$		110		A

Switching Characteristic, Inductive Load

Turn-on Delay Time	$t_{d(on)}$	$V_{CC}=300V, V_{GE}=-5V \sim 15V, I_C = 15A, R_G=51\Omega$		10		nS
Rise Time	t_r			28		
Turn-off Delay Time	$t_{d(off)}$			68		
Fall time	t_f			138		
Turn-off Energy	E_{off}			0.16		mJ
Turn-on Energy	E_{on}			0.33		

Turn-on Delay Time	$t_{d(on)}$	$V_{CC}=300V, V_{GE}=-5V\sim 15V,$ $I_C = 15A, R_G=51\Omega, T_J=125^\circ C$		14	nS
Rise Time	t_r			36	
Turn-off Delay Time	$t_{d(off)}$			69	
Fall time	t_f			161	
Turn-off Energy	E_{off}	$V_{CC}=300V, V_{GE}=-5V\sim 15V,$ $I_C = 15A, R_G=51\Omega, T_J=150^\circ C$		0.27	mJ
Turn-on Energy	E_{on}			0.38	
Turn-on Delay Time	$t_{d(on)}$			16	
Rise Time	t_r			43	
Turn-off Delay Time	$t_{d(off)}$	$V_{CC}=300V, V_{GE}=-5V\sim 15V,$ $I_C = 15A, R_G=51\Omega, T_J=150^\circ C$		69	nS
Fall time	t_f			182	
Turn-off Energy	E_{off}			0.32	
Turn-on Energy	E_{on}			0.43	

Electrical characteristics of the Diode ($T_J=25^\circ C$ unless otherwise noted)

Parameter	Symbol	Test Condition	Min.	Typ.	Max.	Unit
Diode Forward Voltage	V_F	$I_F=15A, T_J=25^\circ C$		1.9	2.4	V
		$I_F=15A, T_J=125^\circ C$		1.7		
		$I_F=15A, T_J=150^\circ C$		1.6		
Reverse Recovery Current	I_{rr}	$I_F=15A, V_R=300V,$ $-di/dt= 380A/\mu s$		6		A
Diode reverse recovery Time	t_{rr}			197		nS
Reverse Recovery Charge	Q_{rr}			0.24		μC
Reverse recovery Energy	E_{rec}			0.06		mJ
Reverse Recovery Current	I_{rr}	$I_F=15A, V_R=300V,$ $-di/dt= 380A/\mu s, T_J=125^\circ C$		7		A
Diode reverse recovery Time	t_{rr}			213		nS
Reverse Recovery Charge	Q_{rr}			0.58		μC
Reverse recovery Energy	E_{rec}			0.11		mJ
Reverse Recovery Current	I_{rr}	$I_F=15A, V_R=300V,$ $-di/dt= 380A/\mu s, T_J=150^\circ C$		8		A
Diode reverse recovery Time	t_{rr}			221		nS
Reverse Recovery Charge	Q_{rr}			0.71		μC
Reverse recovery Energy	E_{rec}			0.14		mJ

Typical Characteristics

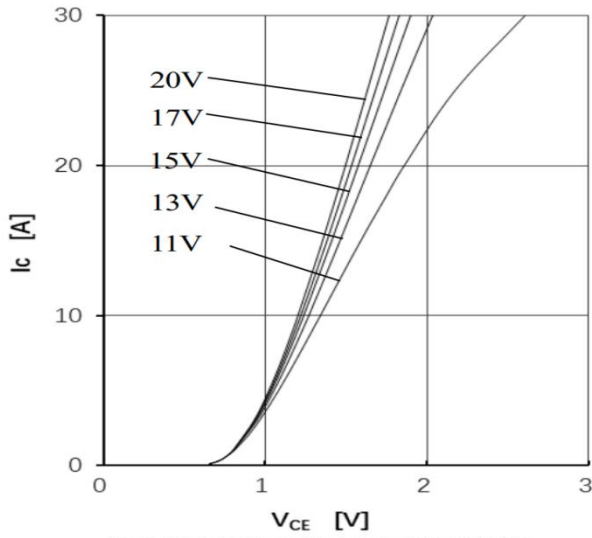

Fig1.IGBT Output Characteristics(25°C)

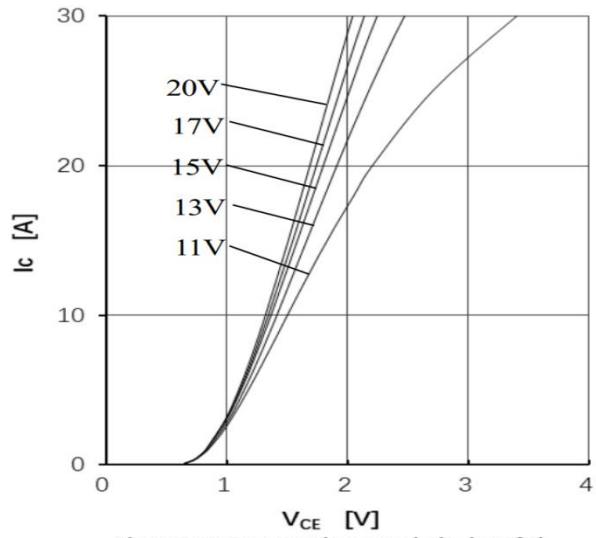

Fig2.IGBT Output Characteristics(150°C)

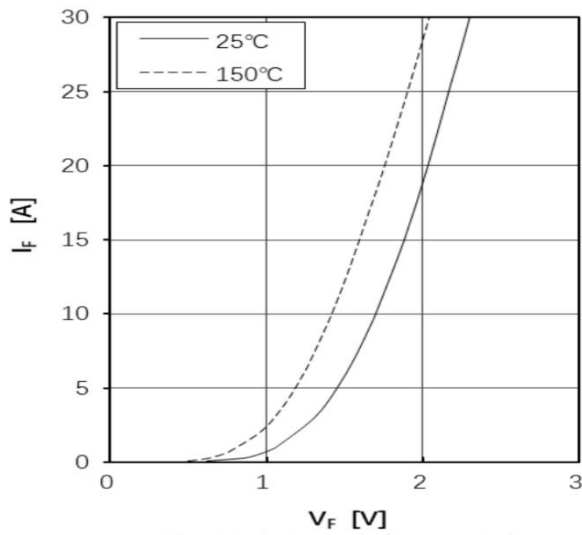

Fig3.Diode Forward Characteristics

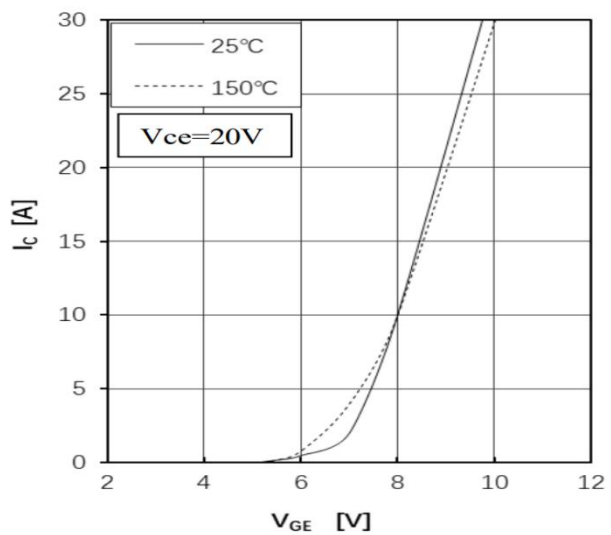

Fig4.IGBT Transfer Characteristics

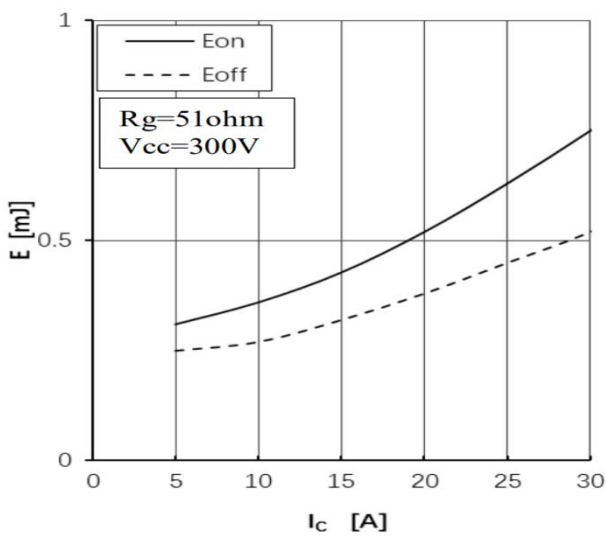

Fig5.IGBT Switching Loss vs.Ic(150°C)

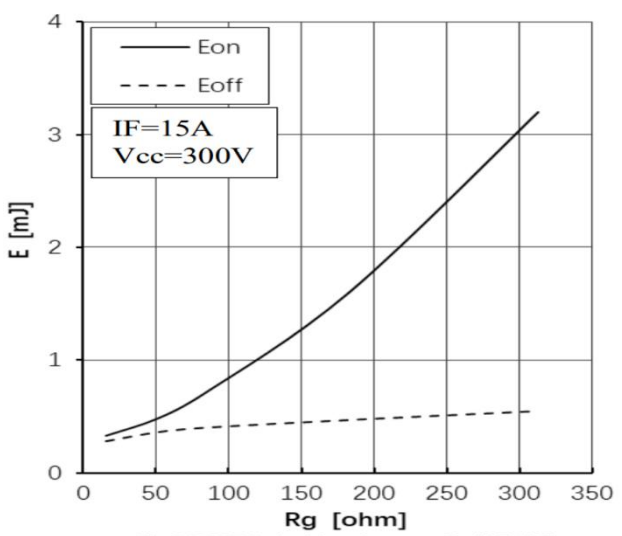

Fig6.IGBT Switching Loss vs.Rg(150°C)

Typical Characteristics

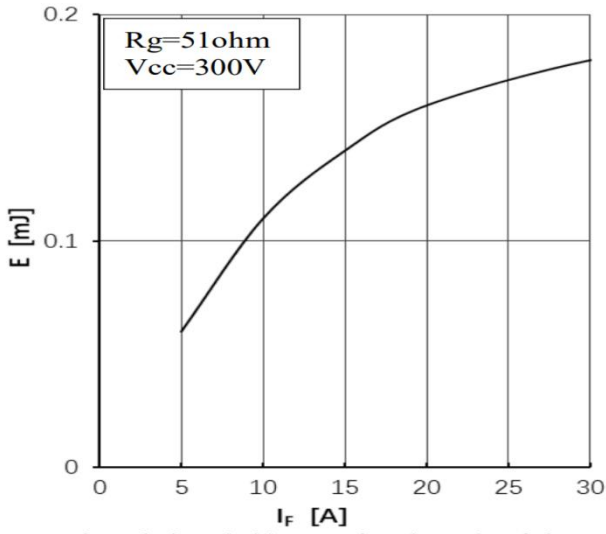

Fig7. Diode Switching Loss(Erec) vs. I_F (150°C)

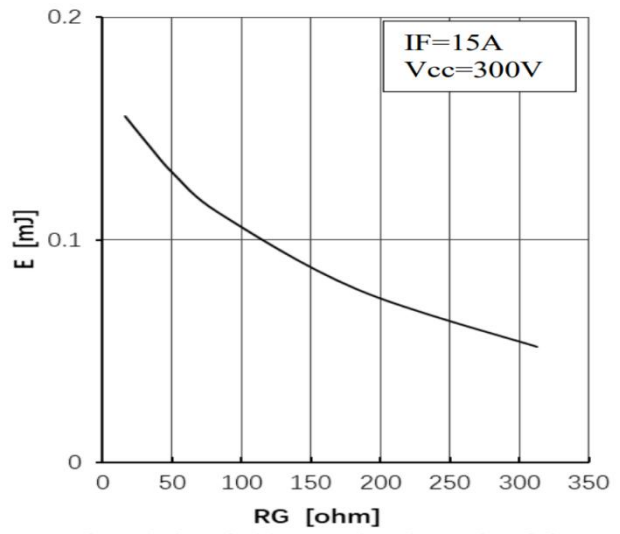

Fig8. Diode Switching Loss(Erec)vs. R_G (150°C)

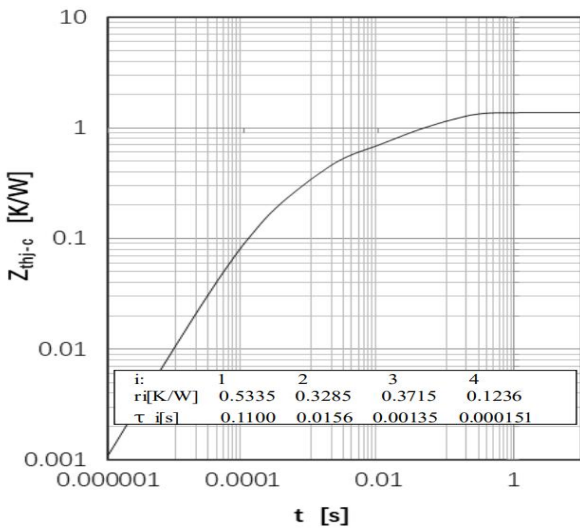

Fig 9. IGBT Transient Thermal Impedance

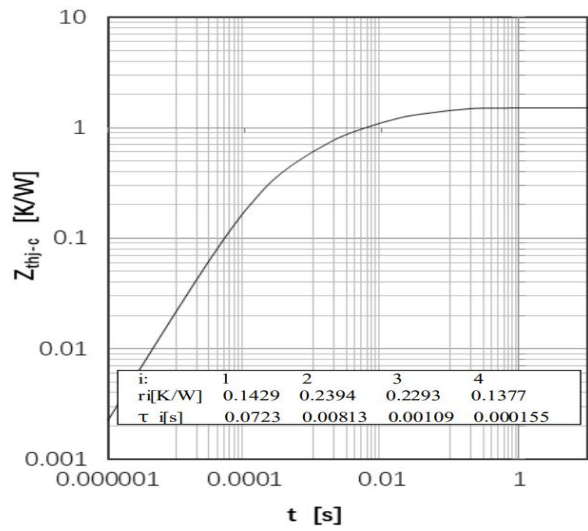
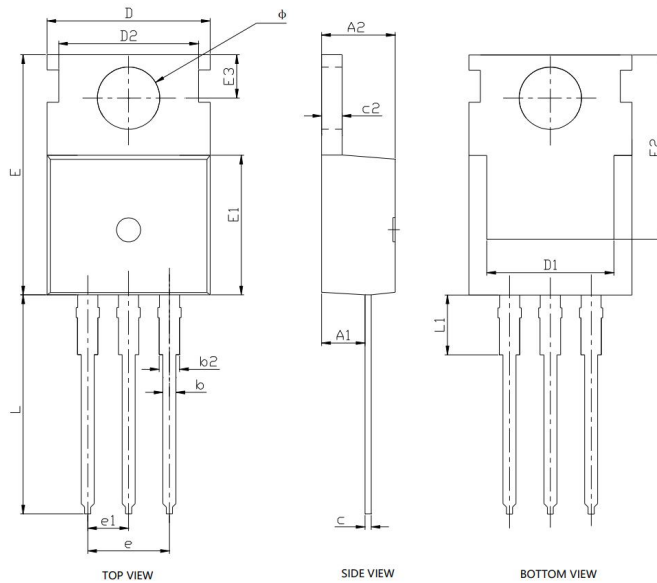

Fig10. Diode Transient Thermal Impedance

TO-220AB Package Information



Symbol	Dimensions In Millimeters		Dimensions In Inches	
	Min.	Max.	Min.	Max.
A1	2.300	2.500	0.091	0.098
A2	4.400	4.600	0.173	0.181
b	0.700	0.900	0.028	0.035
b2	1.250	1.420	0.049	0.056
c	0.450	0.550	0.018	0.022
c2	1.250	1.350	0.049	0.053
D	9.700	10.200	0.382	0.402
D1	7.500	8.400	0.295	0.331
D2	8.500	8.900	0.335	0.350
E	15.300	16.100	0.602	0.634
E1	9.100	9.300	0.358	0.366
E2	12.630	13.330	0.497	0.525
E3	2.700	2.900	0.106	0.114
e	5.080 BSC		0.200 BSC	
e1	2.540 BSC		0.100 BSC	
L	13.000	13.500	0.512	0.531
L1	-	3.500	-	0.138
Φ	3.550	3.750	0.140	0.148