

Product Summary

$V_{(BR)DSS}$	$R_{DS(on)MAX}$	I_D	$V_{(BR)DSS}$	$R_{DS(on)MAX}$	I_D
60V	28mΩ@10V	20A	-60V	60mΩ@-10V	-16A
	32mΩ@4.5V			72mΩ@-4.5V	

Feature

- High density cell design for ultra low RDS(on)
- Fully characterized avalanche voltage and current
- Good stability and uniformity with high E_{AS}
- Excellent package for good heat dissipation
- Special process technology for high ESD capability
- Suffix "-Q1" for AEC-Q101

Application

- H-bridge
- Inverters

Package

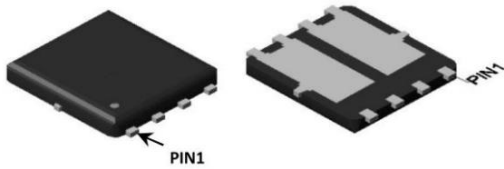

DFN5X6-8L

Circuit diagram

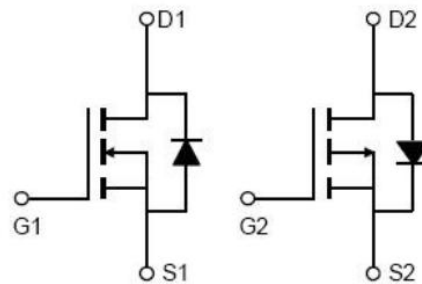

Marking

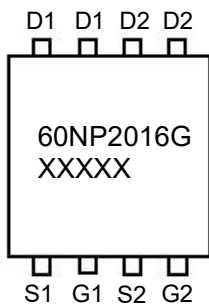

Absolute maximum ratings (Tc=25°C unless otherwise noted)

Parameter	Symbol	N-Channel	p-Channel	Unit
Drain-Source Voltage	V _{DS}	60	-60	V
Gate-Source Voltage	V _{GS}	±20	±20	V
Continuous Drain Current	I _D	20	-16	A
Continuous Drain Current (T _C =100°C)	I _D (100°C)	14	-11.2	A
Pulsed Drain Current ¹⁾	I _{DM}	60	-48	A
Single Pulse Avalanche Energy ⁵⁾	E _{AS}	72	72	mJ
Power Dissipation	P _D	42	42	W
Thermal Resistance, Junction-to-Case ²⁾	R _{θJC}	3	3	°C/W
Junction Temperature	T _J	150		°C
Storage Temperature	T _{STG}	-55 ~ +150		°C

N-CH Electrical characteristics (Tc=25 °C unless otherwise noted)

Parameter	Symbol	Test Condition	Min.	Typ.	Max.	Unit
Static Characteristics						
Drain-source breakdown voltage	V _{(BR)DSS}	V _{GS} = 0V, I _D = 250μA	60			V
Zero gate voltage drain current	I _{DSS}	V _{DS} = 60V, V _{GS} = 0V			1	μA
Gate-body leakage current	I _{GSS}	V _{GS} = ±20V, V _{DS} = 0V			±100	nA
Gate threshold voltage ³⁾	V _{GS(th)}	V _{DS} = V _{GS} , I _D = 250μA	1.2	1.6	2.5	V
Drain-source on-resistance ³⁾	R _{DS(on)}	V _{GS} = 10V, I _D = 10A		23	28	mΩ
		V _{GS} = 4.5V, I _D = 10A		27	32	mΩ
Dynamic characteristics⁴⁾						
Input Capacitance	C _{iss}	V _{DS} = 30V, V _{GS} = 0V, f = 1MHz		973.2		pF
Output Capacitance	C _{oss}			61.2		
Reverse Transfer Capacitance	C _{rss}			58.8		
Total Gate Charge	Q _g	V _{DS} = 30V, V _{GS} = 10V, I _D = 10A		25		nC
Gate-Source Charge	Q _{gs}			4.5		
Gate-Drain Charge	Q _{gd}			6.5		
Turn-on delay time	t _{d(on)}	V _{DD} = 30V, V _{GS} = 10V, R _L = 3Ω, R _G = 3Ω		7		nS
Turn-on rise time	t _r			20		
Turn-off delay time	t _{d(off)}			16		
Turn-off fall time	t _f			23		
Source-Drain Diode characteristics						
Diode Forward Current ²⁾	I _S				20	A
Diode Forward voltage ³⁾	V _{SD}	V _{GS} = 0V, I _S = 10A			1.2	V
Reverse Recovery Time	t _{rr}	T _J = 25°C, I _F = 10A		29		nS
Reverse Recovery Charge	Q _{rr}	di/dt = 100A/μS ³⁾		49		nC

P-CH Electrical characteristics (Tc=25°C unless otherwise noted)

Parameter	Symbol	Test Condition	Min.	Typ.	Max.	Unit
Static Characteristics						
Drain-source breakdown voltage	$V_{(BR)DSS}$	$V_{GS} = 0V, I_D = -250\mu A$	-60			V
Zero gate voltage drain current	I_{DSS}	$V_{DS} = -60V, V_{GS} = 0V$			-1	μA
Gate-body leakage current	I_{GSS}	$V_{GS} = \pm 20V, V_{DS} = 0V$			± 100	nA
Gate threshold voltage ³⁾	$V_{GS(th)}$	$V_{DS} = V_{GS}, I_D = -250\mu A$	-1.0	-1.5	-2.0	V
Drain-source on-resistance ³⁾	$R_{DS(on)}$	$V_{GS} = -10V, I_D = -8A$		52	60	m Ω
		$V_{GS} = -4.5V, I_D = -8A$		60	72	m Ω
Dynamic characteristics⁴⁾						
Input Capacitance	C_{iss}	$V_{DS} = -30V, V_{GS} = 0V, f = 1MHz$		1108		pF
Output Capacitance	C_{oss}			73.7		
Reverse Transfer Capacitance	C_{rss}			58.2		
Total Gate Charge	Q_g	$V_{DS} = -30V, V_{GS} = -10V, I_D = -8A$		23.4		nC
Gate-Source Charge	Q_{gs}			4.1		
Gate-Drain Charge	Q_{gd}			4.8		
Turn-on delay time	$t_{d(on)}$	$V_{DD} = -30V, V_{GS} = -10V, R_L = -3.75\Omega, R_{GEN} = 3\Omega$		8		nS
Turn-on rise time	t_r			4		
Turn-off delay time	$t_{d(off)}$			32		
Turn-off fall time	t_f			7		
Source-Drain Diode characteristics						
Diode Forward Current ²⁾	I_S				-16	A
Diode Forward voltage ³⁾	V_{SD}	$V_{GS} = 0V, I_S = -16A$			-1.2	V
Reverse Recovery Time	t_{rr}	$T_J = 25^\circ C, I_F = -8A, di/dt = -100A/\mu S^3)$		25		nS
Reverse Recovery Charge	Q_{rr}			31		nC

Notes:

- 1) Repetitive Rating: Pulse width limited by maximum junction temperature.
- 2) Surface Mounted on FR4 Board, $t \leq 10$ sec.
- 3) Pulse Test: Pulse Width $\leq 300\mu s$, Duty Cycle $\leq 2\%$.
- 4) Guaranteed by design, not subject to production.
- 5) EAS condition: $T_J = 25^\circ C, V_{DD} = 30V, V_G = 10V, L = 0.5mH, R_g = 25\Omega$.

N- Channel Typical Characteristics

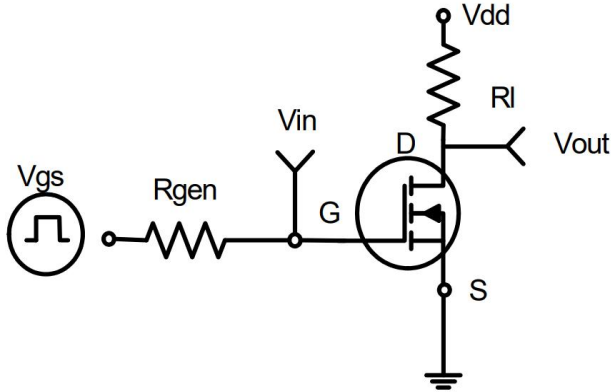

Figure 1: Switching Test Circuit

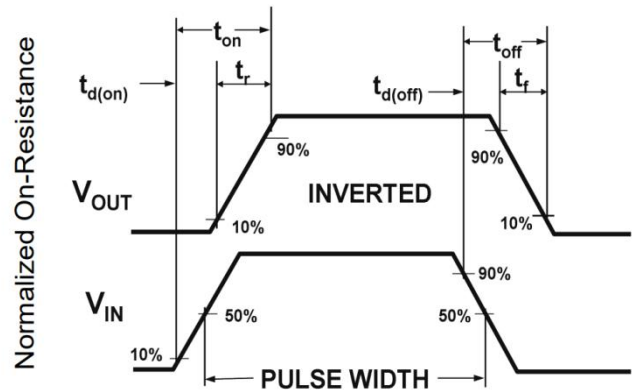

Figure 2: Switching Waveforms

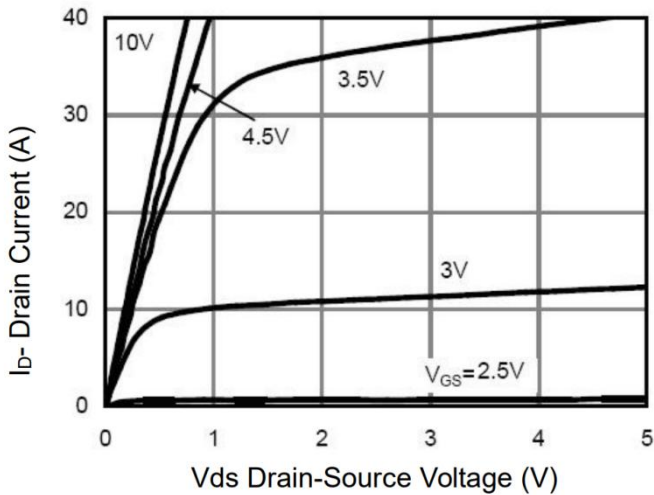

Figure 3 Output Characteristics

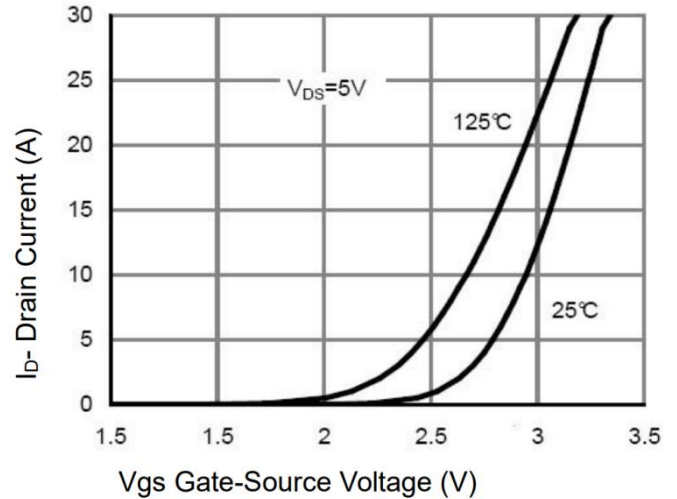

Figure 4 Transfer Characteristics

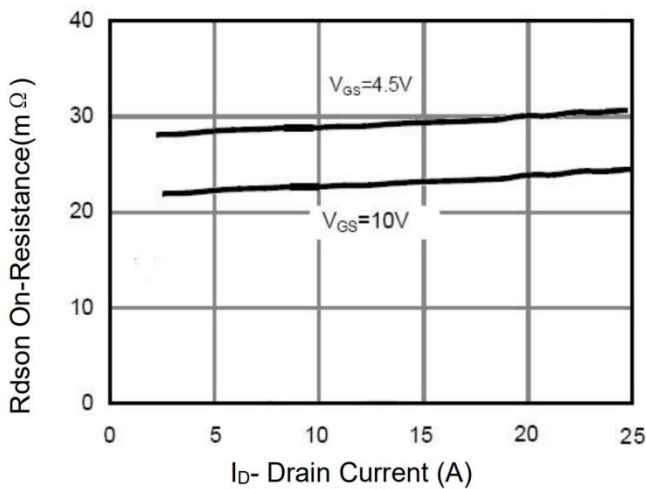

Figure 5 Rdson- Drain Current

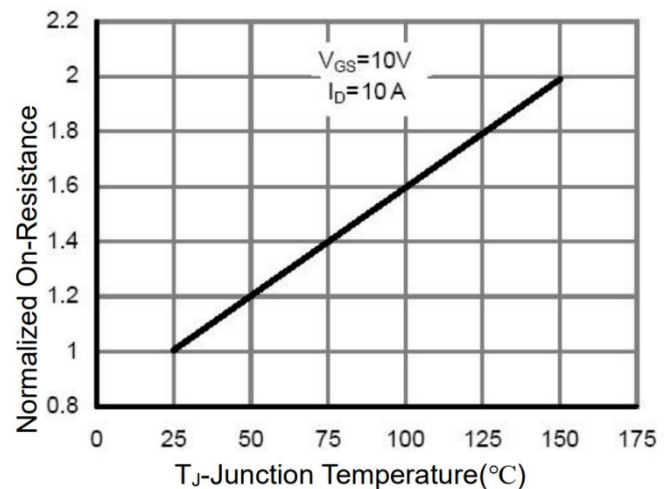
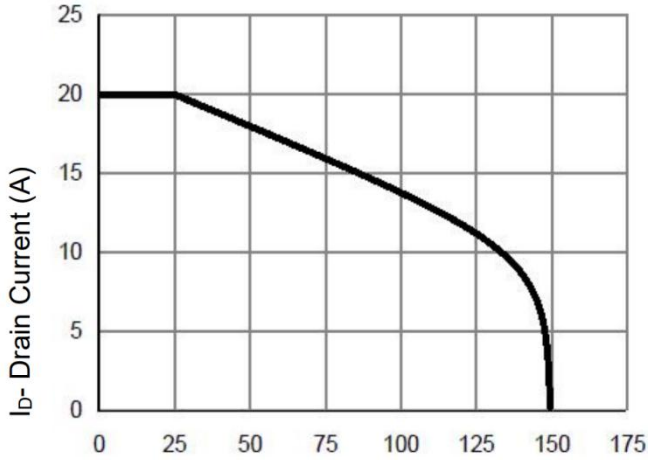
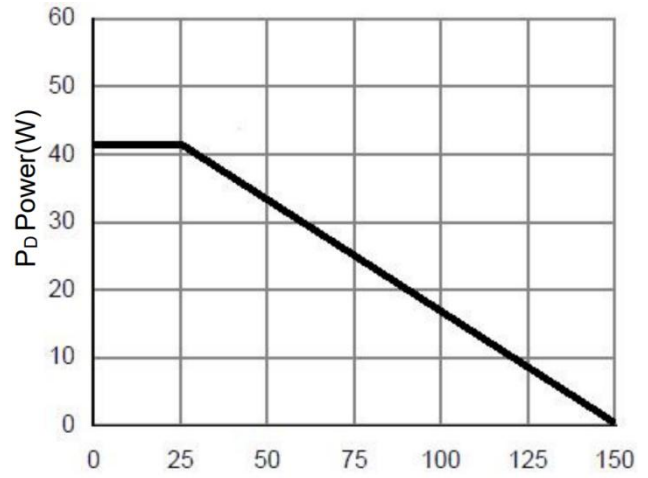

Figure 6 Drain-Source On-Resistance

N- Channel Typical Characteristics



T_J-Junction Temperature(°C)
Figure 7 Rdson vs Vgs



T_J-Junction Temperature(°C)
Figure 8 Power Dissipation

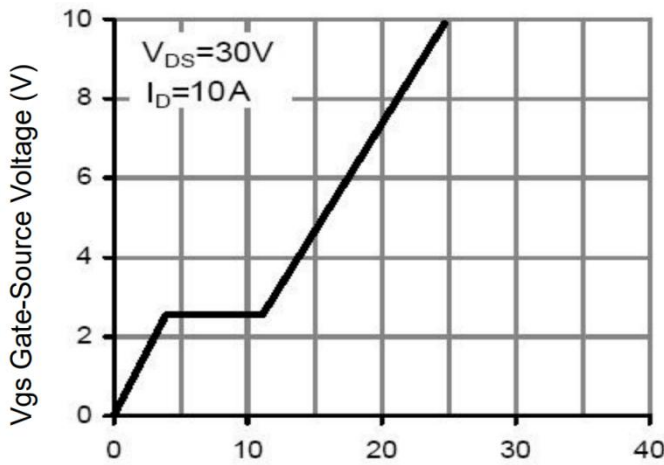

Figure 9 Gate Charge

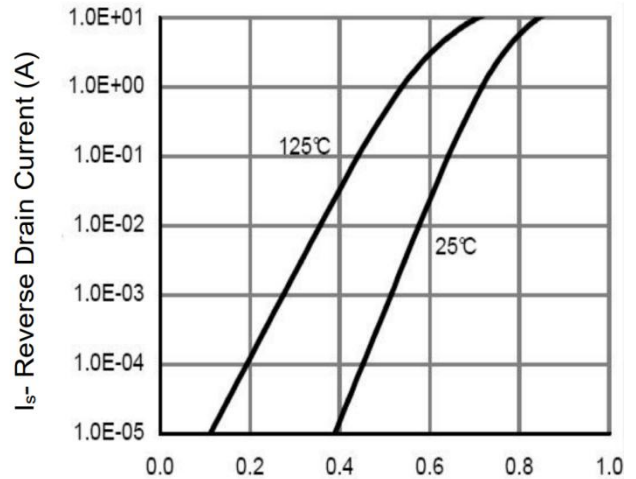

Figure 10 Source- Drain Diode Forward

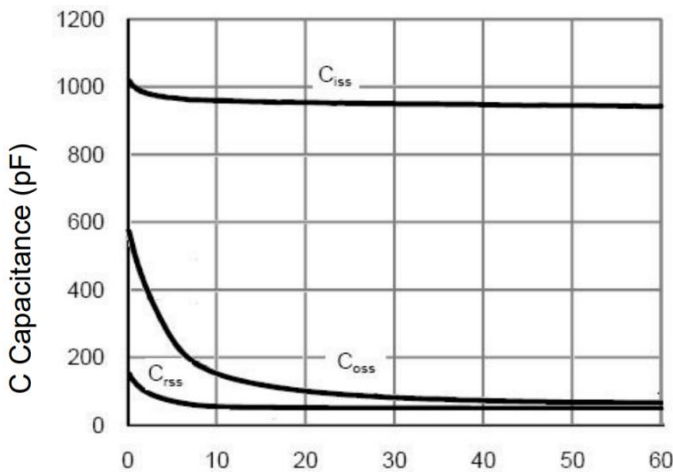
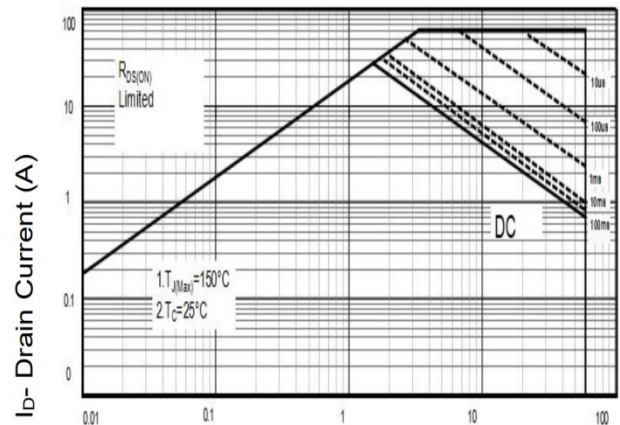

Figure 11 Capacitance vs Vds



V_{ds} Drain-Source Voltage (V)
Figure 12 Safe Operation Area

N- Channel Typical Characteristics

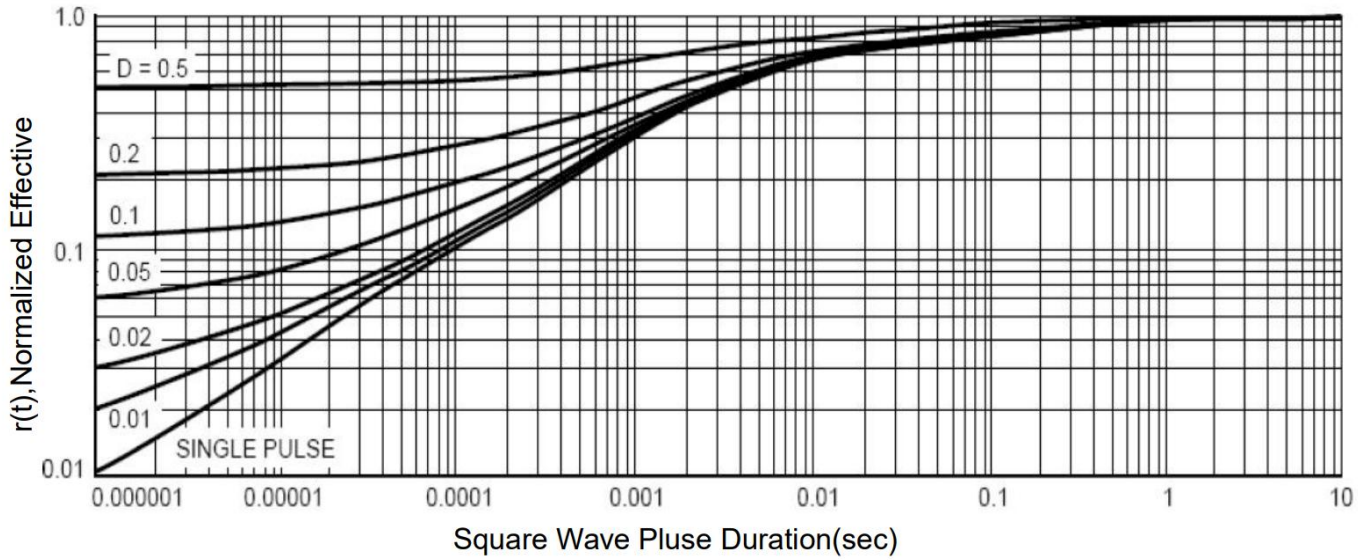

Figure 13 Normalized Maximum Transient Thermal Impedance

P-Channel Typical Characteristics

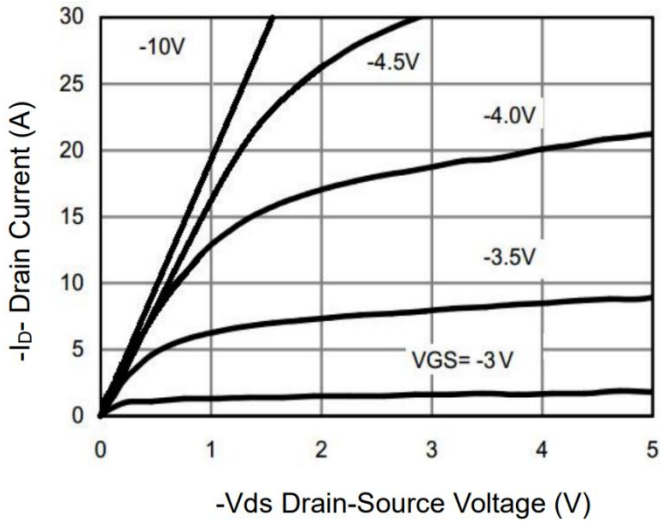

Figure 1 Output Characteristics

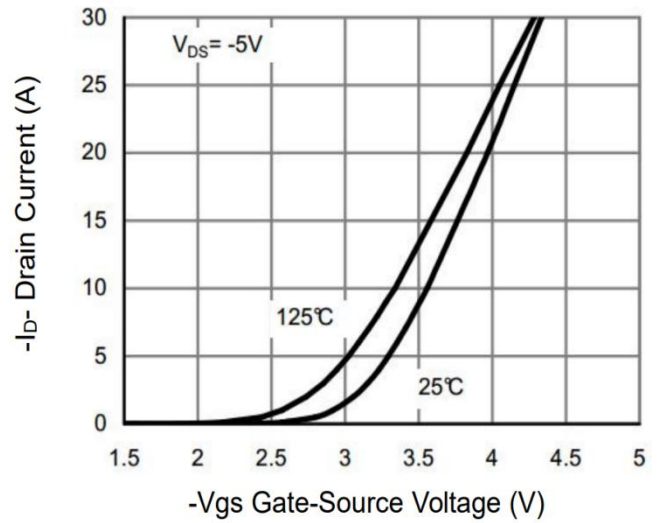

Figure 2 Transfer Characteristics

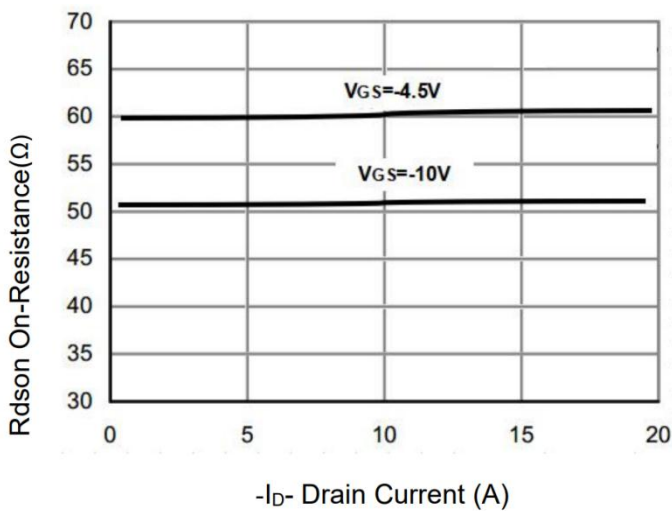

Figure 3 Rdson- Drain Current

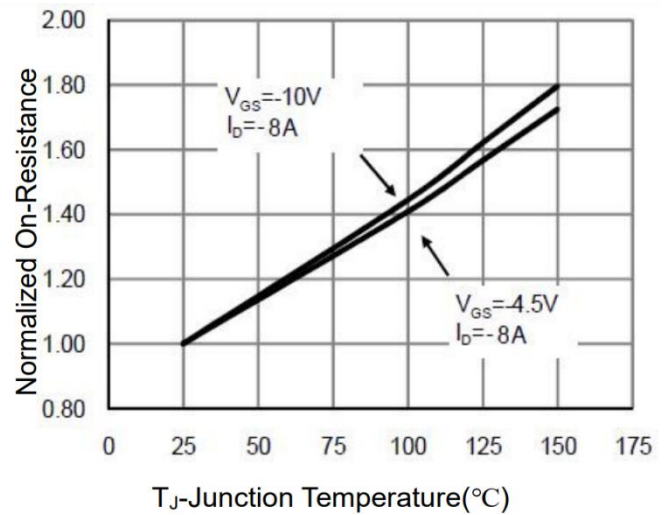

Figure 4 Rdson-Junction Temperature

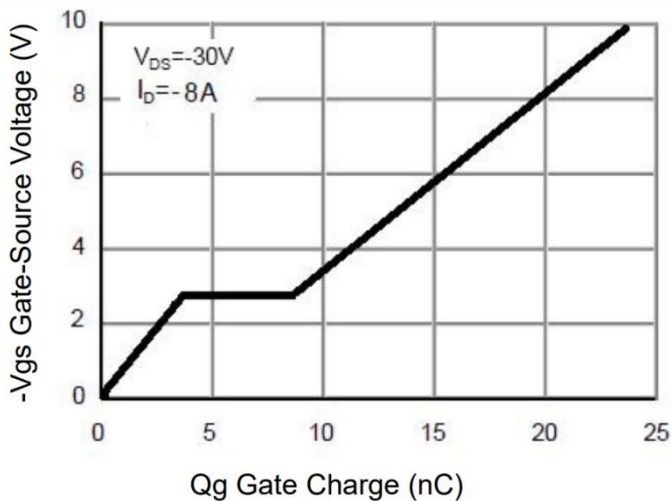

Figure 5 Gate Charge

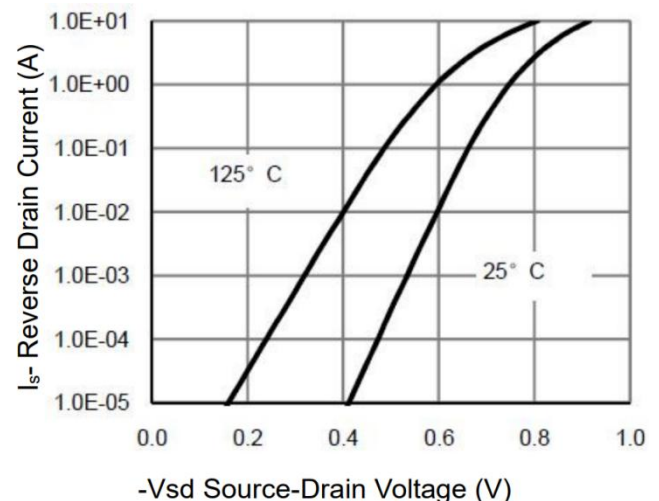
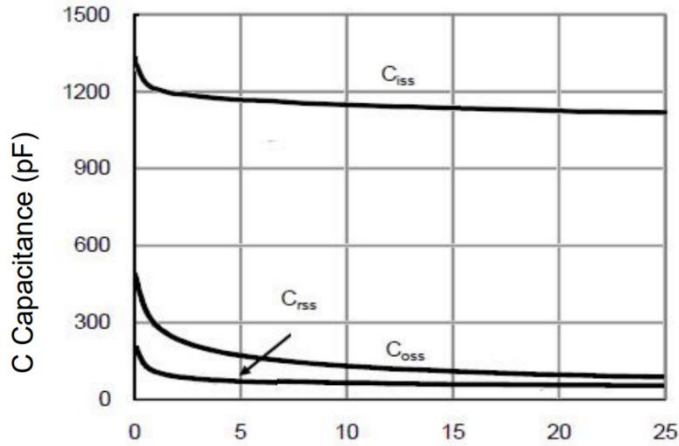
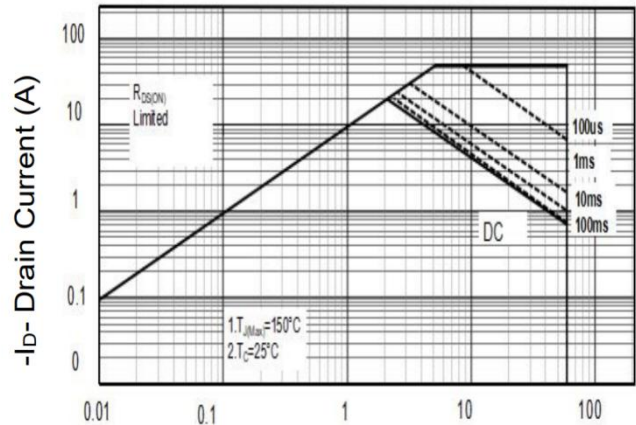

Figure 6 Source- Drain Diode Forward

P- Channel Typical Characteristics



-Vds Drain-Source Voltage (V)
Figure 7 Capacitance vs Vds



-Vds Drain-Source Voltage (V)
Figure 8 Safe Operation Area

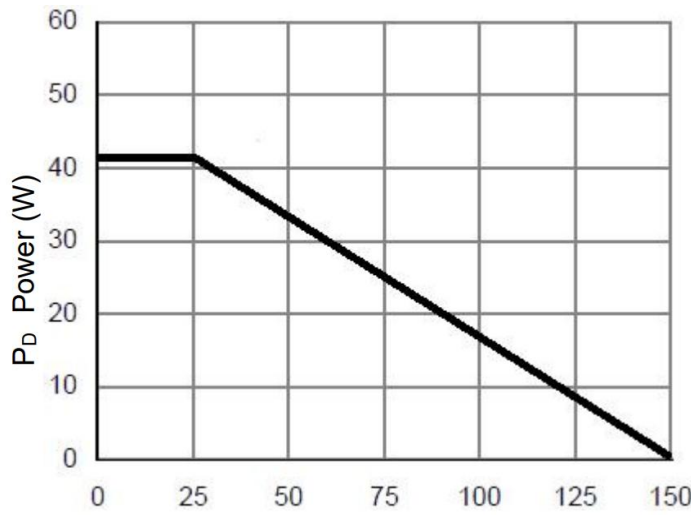

T_J-Junction Temperature(°C)
Figure 9 Power Dissipation

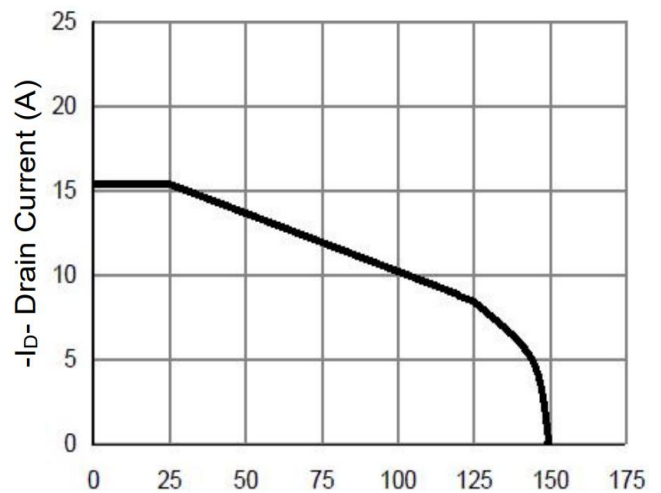

T_J-Junction Temperature(°C)
Figure 10 ID Current De-rating

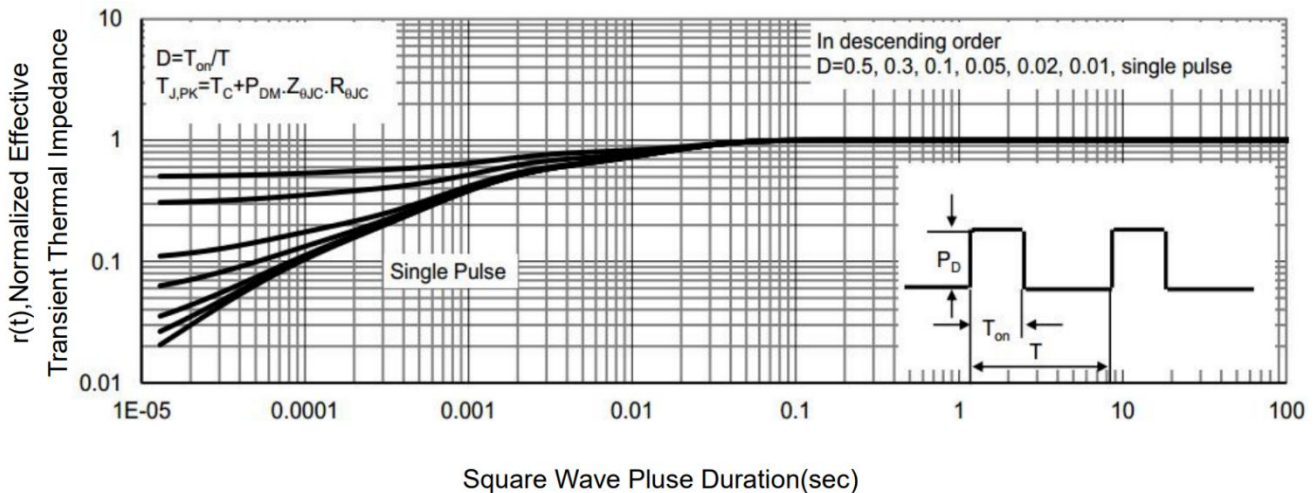
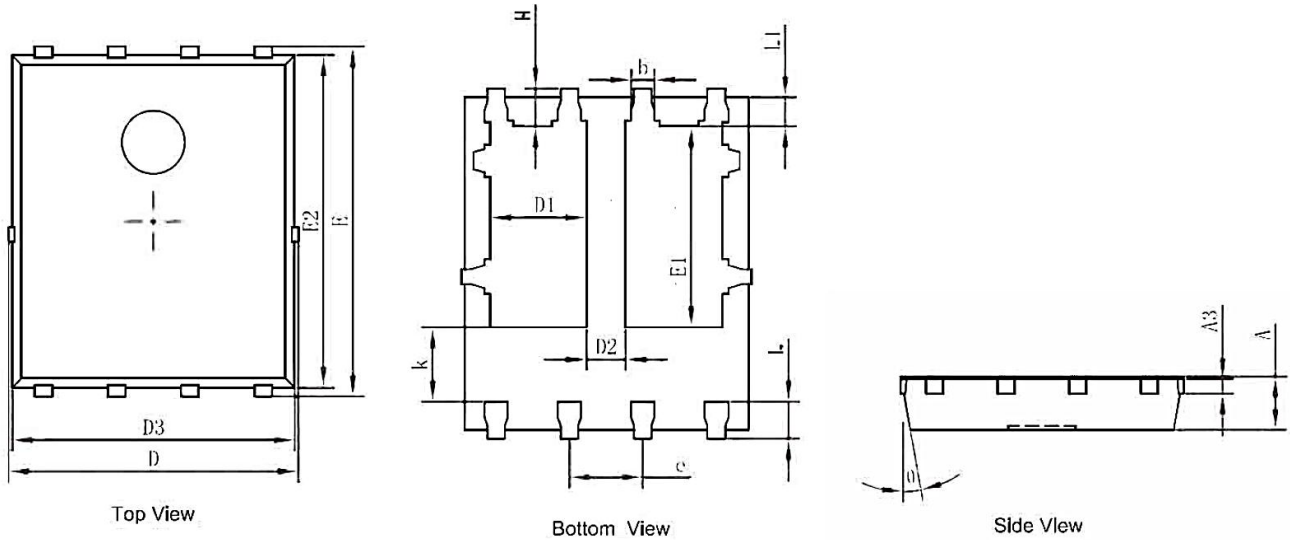

Figure 11 Normalized Maximum Transient Thermal Impedance

DFN5X6-8L Package Information



Symbol	Dimensions In Millimeters		Dimensions In Inches	
	Min.	Max.	Min.	Max.
A	0.900	1.000	0.035	0.039
A3	0.254 REF		0.010 REF	
D	4.944	5.096	0.195	0.201
E	5.974	6.126	0.235	0.241
D1	1.470	1.870	0.058	0.074
D2	0.470	0.870	0.019	0.034
E1	3.375	3.575	0.133	0.141
D3	4.824	4.976	0.190	0.196
E2	5.674	5.826	0.223	0.229
k	1.190	1.390	0.047	0.055
b	0.350	0.450	0.014	0.018
e	1.270 TYP		0.050 TYP	
L	0.559	0.711	0.022	0.028
L1	0.424	0.576	0.017	0.023
H	0.574	0.726	0.023	0.029
θ	10°	12°	10°	12°