

### Product Summary

$V_{(BR)DSS}$	$R_{DS(on)MAX}$	$I_D@25^{\circ}C$
650V	50mΩ@18V	55A

### Feature

- High Blocking Voltage With Low On-Resistance
- High Speed Switching With Low Capacitance
- Fast Intrinsic Diode with Low Reverse Recovery (Qrr)

### Application

- EV Charging
- Server Power Supplies
- Solar PV Inverters
- UPS
- DC/DC Converters

### Package



TO-247-4

### Marking

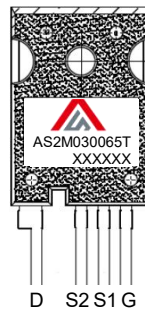

D S2 S1 G

### Circuit diagram

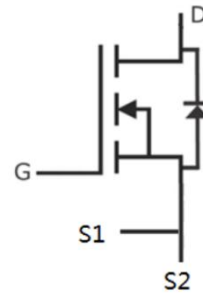

### Absolute maximum ratings ( $T_C=25^{\circ}C$ unless otherwise noted)

Parameter	Symbol	Test Condition	Value	Unit
Drain-Source Voltage	$V_{DSmax}$	$V_{GS} = 0V, I_D = 100\mu A$	650	V
Gate-Source Voltage	$V_{GSmax}$	Absolute maximum values	-8/+22	V
Gate-Source Voltage	$V_{GSOP}$	Recommended operational values	-4/+18	V
Continuous Drain Current	$I_D$	$V_{GS}=18V, T_C=25^{\circ}C$	55	A
	$I_D$	$V_{GS}=18V, T_C=100^{\circ}C$	39	A
Power Dissipation	$P_D$	$T_C=25^{\circ}C$	187	W
Thermal Resistance (Typ)	$R_{\theta JC}$	Junction-to-Case	0.8	$^{\circ}C/W$
Junction Temperature	$T_J$		-40~ +175	$^{\circ}C$
Storage Temperature	$T_{STG}$		-40~ +175	$^{\circ}C$

### Electrical characteristics (T<sub>c</sub>=25°C, unless otherwise noted)

Parameter	Symbol	Test Condition	Min.	Typ.	Max.	Unit
<b>Static Characteristics</b>						
Drain-source breakdown voltage	V <sub>(BR)DSS</sub>	V <sub>GS</sub> = 0V, I <sub>D</sub> = 1mA	650			V
Zero gate voltage drain current	I <sub>DSS</sub>	V <sub>DS</sub> = 650V, V <sub>GS</sub> = 0V		1	50	μA
Gate-Source leakage current	I <sub>GSS</sub>	V <sub>GS</sub> = 22V, V <sub>DS</sub> = 0V		10	250	nA
Gate threshold voltage	V <sub>GS(th)</sub>	V <sub>DS</sub> = V <sub>GS</sub> , I <sub>D</sub> = 10mA	1.8	2.6	4.3	V
Drain-source on-resistance	R <sub>DS(on)</sub>	V <sub>GS</sub> = 18V, I <sub>D</sub> = 25A		30	50	mΩ
		V <sub>GS</sub> = 18V, I <sub>D</sub> = 25A, T <sub>j</sub> = 175°C		42		mΩ
<b>Dynamic characteristics</b>						
Input Capacitance	C <sub>iss</sub>	V <sub>DS</sub> = 400V, V <sub>GS</sub> = 0V, f = 1MHz V <sub>AC</sub> = 25mV		2000		pF
Output Capacitance	C <sub>oss</sub>			180		
Reverse Transfer Capacitance	C <sub>rss</sub>			19		
Total Gate Charge	Q <sub>g</sub>	V <sub>DS</sub> = 400V, V <sub>GS</sub> = -4V/18V, I <sub>D</sub> = 25A		110		nC
Gate-Source Charge	Q <sub>gs</sub>			30		
Gate-Drain Charge	Q <sub>gd</sub>			32		
Turn-on delay time	t <sub>d(on)</sub>	V <sub>DS</sub> = 400V, V <sub>GS</sub> = -4V/18V, I <sub>D</sub> = 25A, R <sub>g(ext)</sub> = 2.5Ω, R <sub>L</sub> = 16Ω		14		nS
Turn-on rise time	t <sub>r</sub>			15		
Turn-off delay time	t <sub>d(off)</sub>			28		
Turn-off fall time	t <sub>f</sub>			8		
Turn-On Energy	E <sub>on</sub>	V <sub>DS</sub> = 400V, V <sub>GS</sub> = -4V/18V, I <sub>D</sub> = 25A, R <sub>g(ext)</sub> = 2.5Ω, L = 100μH		50		μJ
Turn-Off Energy	E <sub>off</sub>			65		
<b>Source-Drain Diode characteristics</b>						
Diode Forward Current	I <sub>S</sub>	V <sub>GS</sub> = -4V			45	A
Diode Forward voltage	V <sub>SD</sub>	V <sub>GS</sub> = -4V, I <sub>SD</sub> = 12.5A		4.2		V
		V <sub>GS</sub> = -4V, I <sub>SD</sub> = 12.5A, T <sub>J</sub> = 175°C		3.8		V
Reverse Recovery Time	t <sub>rr</sub>	I <sub>SD</sub> = 25A, V <sub>R</sub> = 400V		25		nS
Reverse Recovery Charge	Q <sub>rr</sub>			100		nC
Peak Reverse Recovery Current	I <sub>rrm</sub>			5		A

## Typical Characteristics

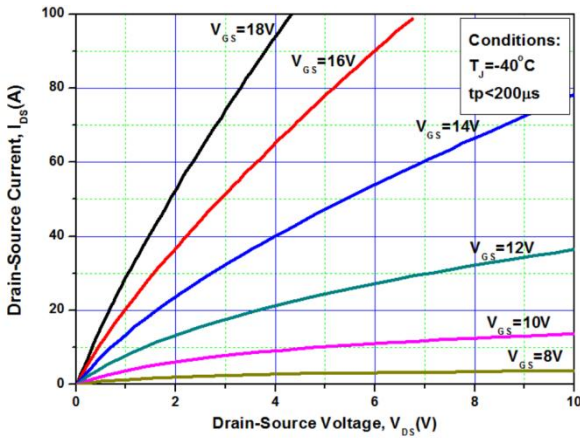

Figure 1. Output Characteristics  $T_j = -40^\circ\text{C}$

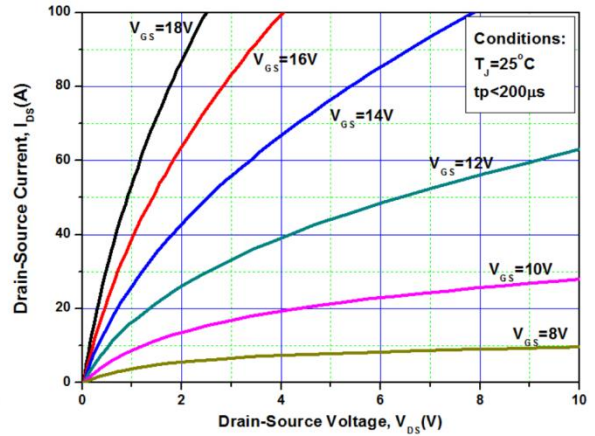

Figure 2. Output Characteristics  $T_j = 25^\circ\text{C}$

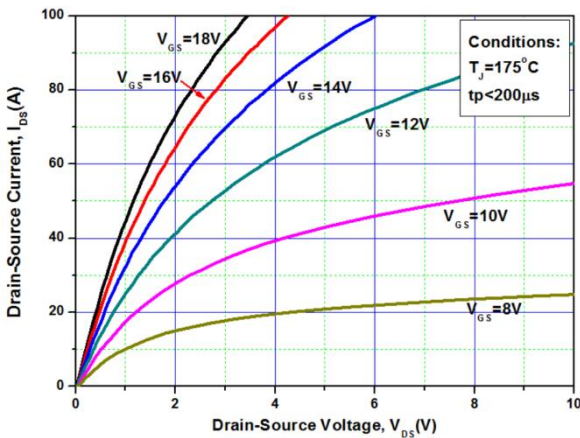

Figure 3. Output Characteristics  $T_j = 175^\circ\text{C}$

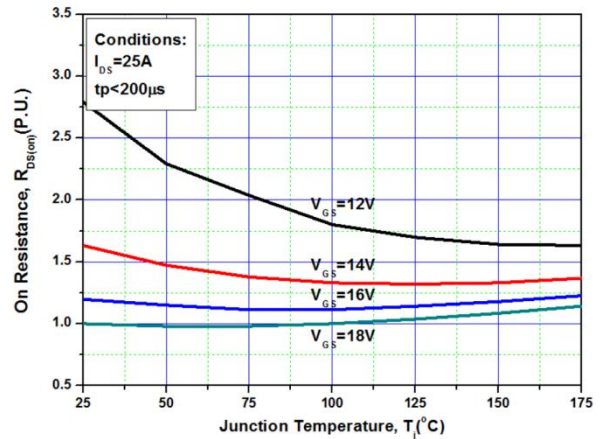

Figure 4. Normalized On-Resistance vs. Temperature

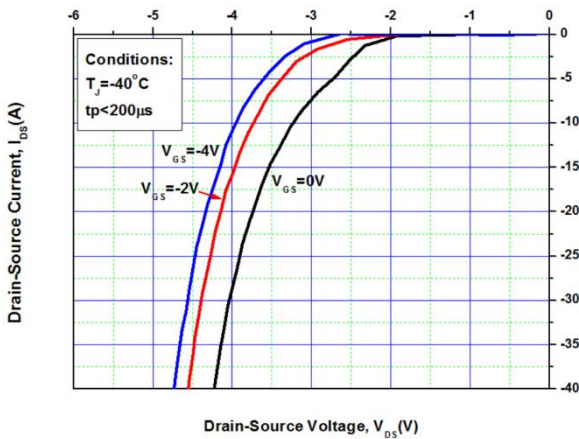

Figure 5. Body Diode Characteristic at  $-40^\circ\text{C}$

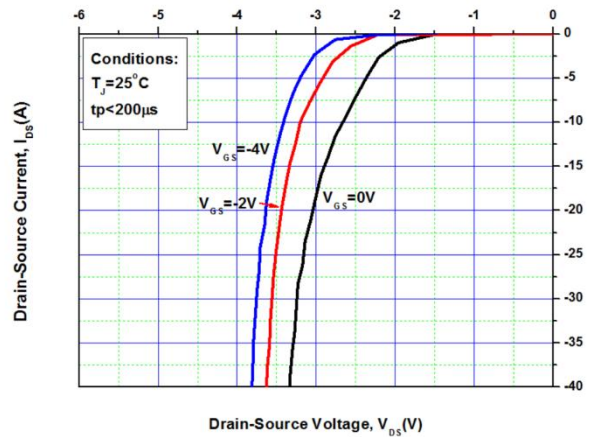

Figure 6. Body Diode Characteristic at  $25^\circ\text{C}$



## Typical Characteristics

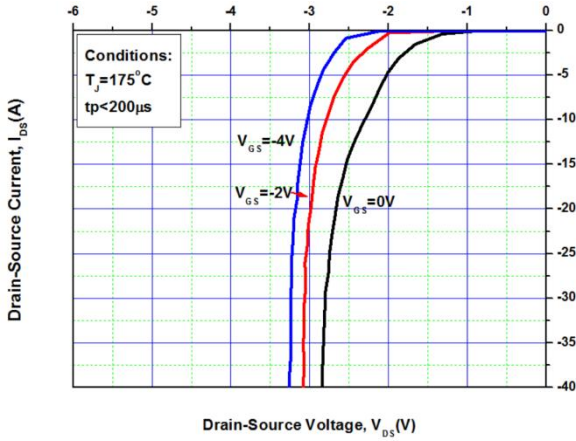

Figure 7. Body Diode Characteristic at 175°C

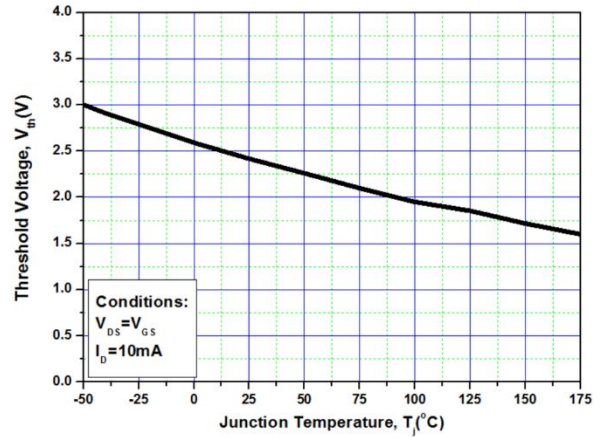

Figure 8. Threshold Voltage vs. Temperature

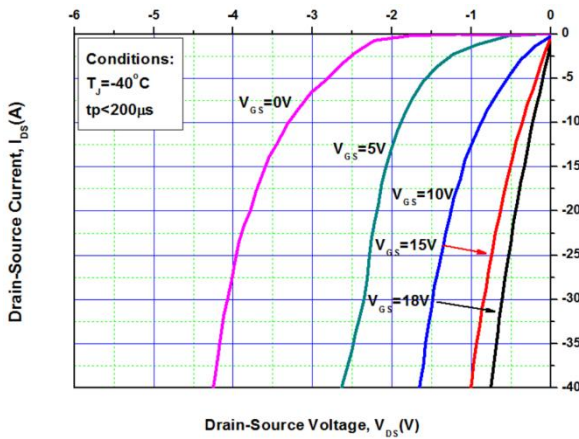

Figure 9. 3rd Quadrant Characteristic at -40°C

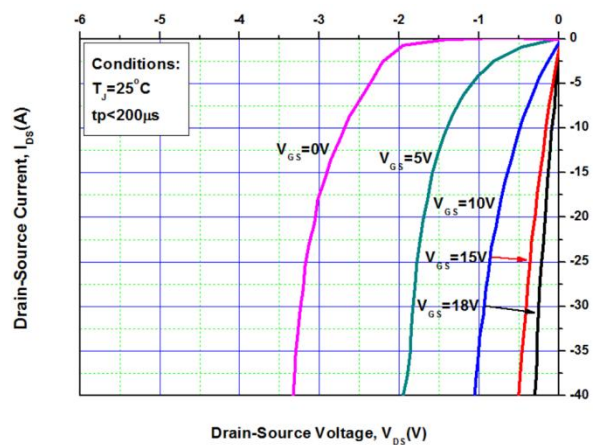

Figure 10. 3rd Quadrant Characteristic at 25°C

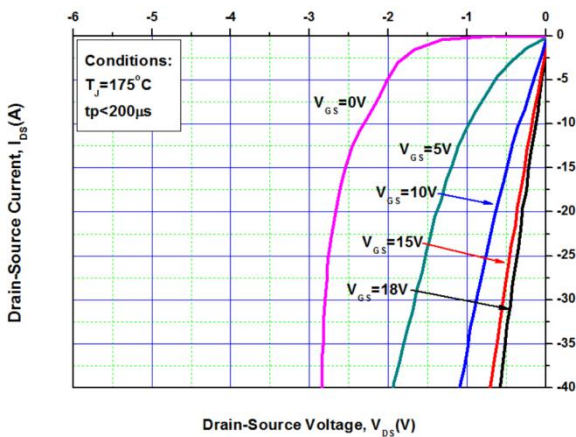

Figure 11. 3rd Quadrant Characteristic at 175°C

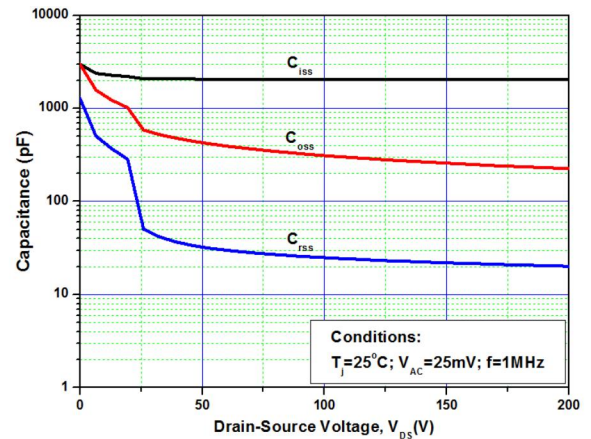

Figure 12. Capacitances vs. Drain-Source Voltage (0 - 200V)

## Typical Characteristics

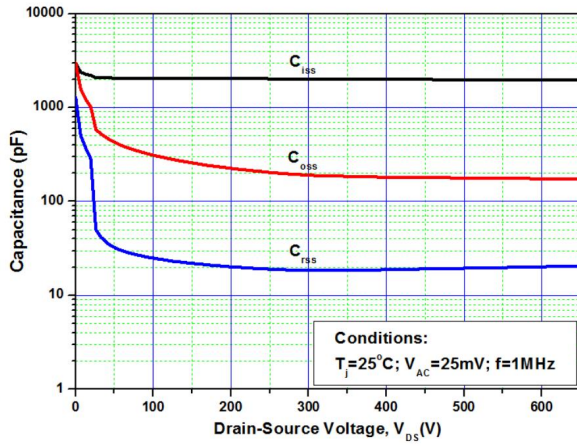
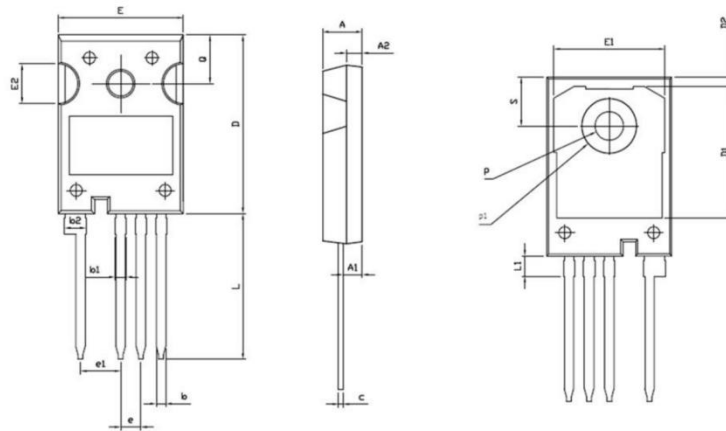

Figure 13. Capacitances vs. Drain-Source Voltage (0 - 650V)

### TO-247-4 Package Information



Symbol	Dimensions In Millimeters		Dimensions In Inches	
	Min.	Max.	Min.	Max.
A	4.800	5.200	0.189	0.205
A1	2.250	2.450	0.089	0.096
A2	1.850	2.150	0.073	0.085
b	1.050	1.350	0.041	0.053
b1	1.000	1.600	0.039	0.063
b2	2.350	2.950	0.093	0.116
c	0.500	0.700	0.020	0.028
D	22.340	22.740	0.880	0.895
D1	16.000	17.000	0.630	0.669
D2	0.970	1.370	0.038	0.054
e	2.340	2.740	0.092	0.108
e1	4.880	5.280	0.192	0.208
E	15.600	16.000	0.614	0.630
E1	13.500	14.500	0.531	0.571
E2	4.800	5.200	0.189	0.205
L	18.080	18.680	0.712	0.735
L1	2.380	2.780	0.094	0.109
P	3.500	3.700	0.138	0.146
p1	6.600	7.000	0.260	0.276
Q	6.000	6.300	0.236	0.248
S	6.000	6.300	0.236	0.248