

Product Summary

$V_{(BR)DSS}$	$R_{DS(on)MAX}$	I_D	$V_{(BR)DSS}$	$R_{DS(on)MAX}$	I_D
40V	19mΩ@10V	8A	-40V	35mΩ@-10V	-7A
	29mΩ@4.5V			45mΩ@-4.5V	

Feature

- Advanced trench process technology
- High power and current handing capability
- Lead free product is acquired
- Surface mount package

Application

- H-bridge
- DC/DC Converter
- Inverters

Package



SOP-8

Circuit diagram

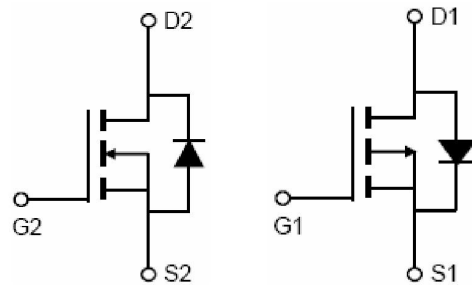

Marking



Absolute maximum ratings (Ta=25°C unless otherwise noted)

Parameter	Symbol	N-Channel	p-Channel	Unit
Drain-Source Voltage	V_{DS}	40	-40	V
Gate-Source Voltage	V_{GS}	± 20	± 20	V
Continuous Drain Current	I_D	8	-7	A
Pulsed Drain Current ¹⁾	I_{DM}	40	-30	A
Power Dissipation	P_D	2	2	W
Thermal Resistance, Junction-to-Ambient ²⁾	$R_{\theta JA}$	62.5	62.5	°C/W
Junction Temperature	T_J	150	150	°C
Storage Temperature	T_{STG}	-55 ~ +150	-55 ~ +150	°C

N-CH Electrical characteristics (Ta=25°C unless otherwise noted)

Parameter	Symbol	Test Condition	Min	Typ	Max	Unit
Static Characteristics						
Drain-source breakdown voltage	$V_{(BR)DSS}$	$V_{GS} = 0V, I_D = 250\mu A$	40			V
Zero gate voltage drain current	I_{DSS}	$V_{DS} = 40V, V_{GS} = 0V$			1	μA
Gate-body leakage current	I_{GSS}	$V_{GS} = \pm 20V, V_{DS} = 0V$			± 100	nA
Gate threshold voltage ³⁾	$V_{GS(th)}$	$V_{DS} = V_{GS}, I_D = 250\mu A$	1.0	1.5	2.0	V
Drain-source on-resistance ³⁾	$R_{DS(on)}$	$V_{GS} = 10V, I_D = 8A$		14	19	m Ω
		$V_{GS} = 4.5V, I_D = 4A$		19	29	m Ω
Dynamic characteristics⁴⁾						
Input Capacitance	C_{iss}	$V_{DS} = 20V, V_{GS} = 0V, f = 1MHz$		1110		pF
Output Capacitance	C_{oss}			114		
Reverse Transfer Capacitance	C_{rss}			109		
Total Gate Charge	Q_g	$V_{DS} = 20V, V_{GS} = 10V, I_D = 8A$		30		nC
Gate-Source Charge	Q_{gs}			5		
Gate-Drain Charge	Q_{gd}			7		
Turn-on delay time	$t_{d(on)}$	$V_{DD} = 20V, V_{GS} = 10V$ $R_L = 2.5\Omega, R_{GEN} = 3\Omega$		5.5		nS
Turn-on rise time	t_r			14		
Turn-off delay time	$t_{d(off)}$			24		
Turn-off fall time	t_f			12		
Source-Drain Diode characteristics						
Diode Forward voltage ³⁾	V_{SD}	$V_{GS} = 0V, I_S = 8A$			1.2	V

P-CH Electrical characteristics (Ta=25°C unless otherwise noted)

Parameter	Symbol	Test Condition	Min	Typ	Max	Unit
Static Characteristics						
Drain-source breakdown voltage	$V_{(BR)DSS}$	$V_{GS}=0V, I_D=-250\mu A$	-40			V
Zero gate voltage drain current	I_{DSS}	$V_{DS}=-40V, V_{GS}=0V$			-1	μA
Gate-body leakage current	I_{GSS}	$V_{GS}=\pm 20V, V_{DS}=0V$			± 100	nA
Gate threshold voltage ³⁾	$V_{GS(th)}$	$V_{DS}=V_{GS}, I_D=-250\mu A$	-1.0	-1.5	-2.0	V
Drain-source on-resistance ³⁾	$R_{DS(on)}$	$V_{GS}=-10V, I_D=-7A$		29	35	m Ω
		$V_{GS}=-4.5V, I_D=-4A$		34	45	m Ω
Dynamic characteristics⁴⁾						
Input Capacitance	C_{iss}	$V_{DS}=-20V, V_{GS}=0V, f=1MHz$		1139		pF
Output Capacitance	C_{oss}			114		
Reverse Transfer Capacitance	C_{rss}			103		
Total Gate Charge	Q_g	$V_{DS}=-20V, V_{GS}=-10V, I_D=-7A$		22.5		nC
Gate-Source Charge	Q_{gs}			2.4		
Gate-Drain Charge	Q_{gd}			5.1		
Turn-on delay time	$t_{d(on)}$	$V_{DD}=-20V, V_{GS}=-10V, R_L=2.9\Omega, R_{GEN}=6\Omega$		7.5		nS
Turn-on rise time	t_r			5.5		
Turn-off delay time	$t_{d(off)}$			19		
Turn-off fall time	t_f			7		
Source-Drain Diode characteristics						
Diode Forward voltage ³⁾	V_{SD}	$V_{GS}=0V, I_S=-7A$			-1.2	V

Notes:

- 1) Repetitive Rating: Pulse width limited by maximum junction tempera.
- 2) Surface Mounted on FR4 Board, $t_s \leq 10$ sec.
- 3) Pulse Test: Pulse Width < 300 μs , Duty Cycle $\leq 2\%$.
- 4) Guaranteed by design, not subject to production.

N- Channel Typical Characteristics

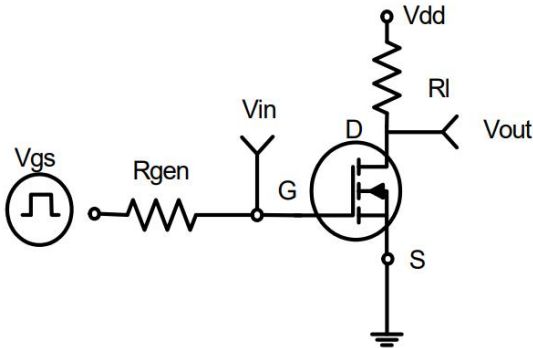

Figure 1: Switching Test Circuit

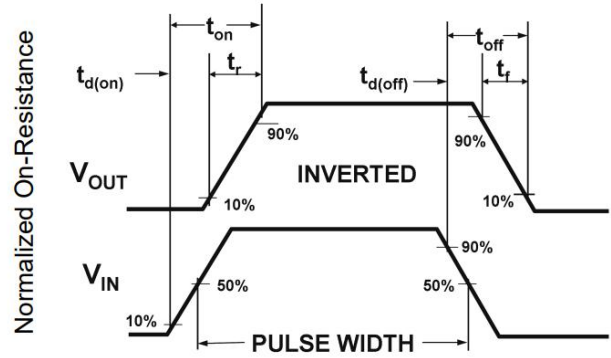

Figure 2: Switching Waveforms

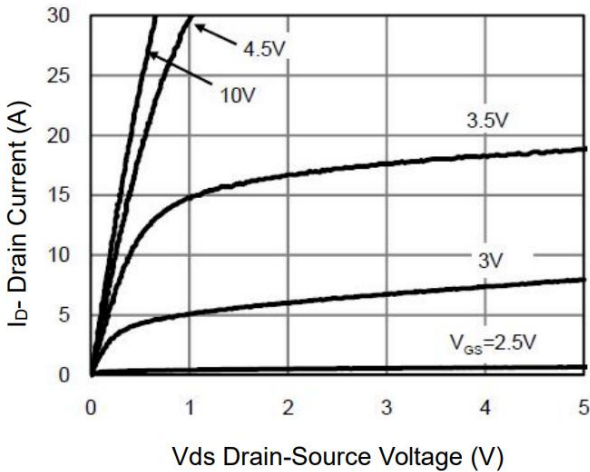

Figure 3 Output Characteristics

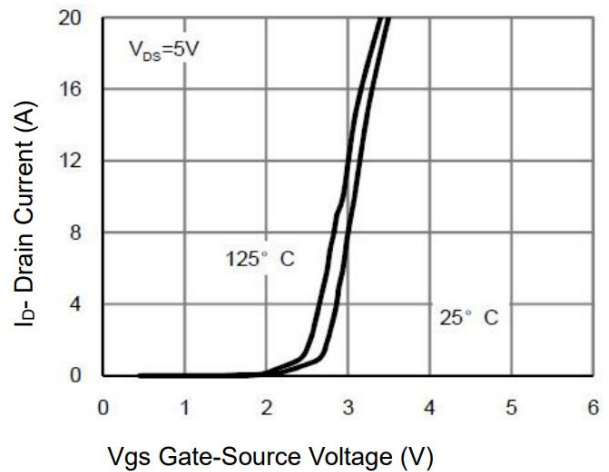

Figure 4 Transfer Characteristics

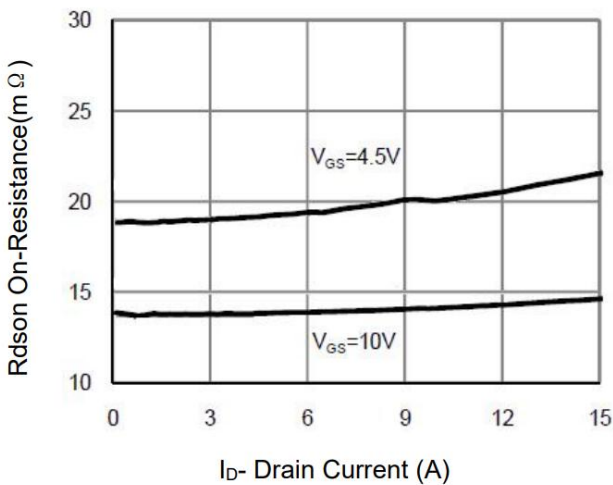

Figure 5 Drain-Source On-Resistance

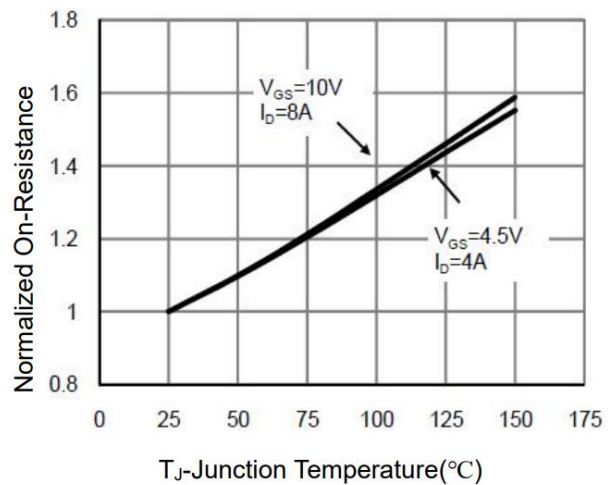
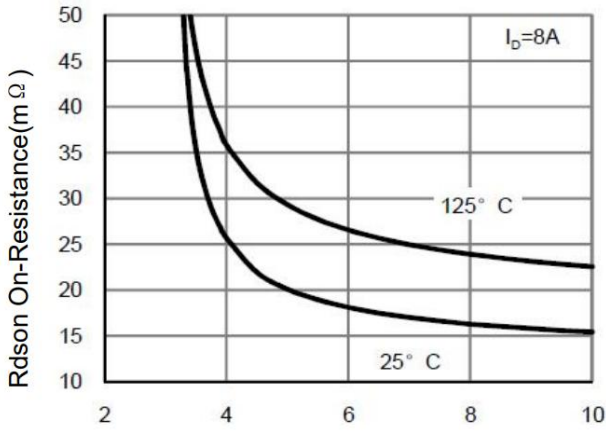
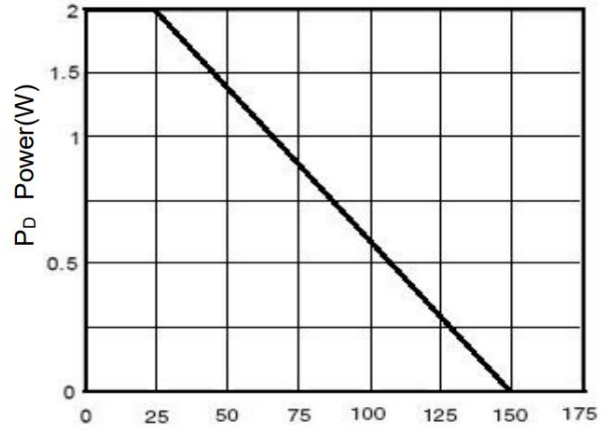

Figure 6 Drain-Source On-Resistance

N- Channel Typical Characteristics



Vgs Gate-Source Voltage (V)
Figure 7 Rdson vs Vgs



T_J-Junction Temperature(°C)
Figure 8 Power Dissipation

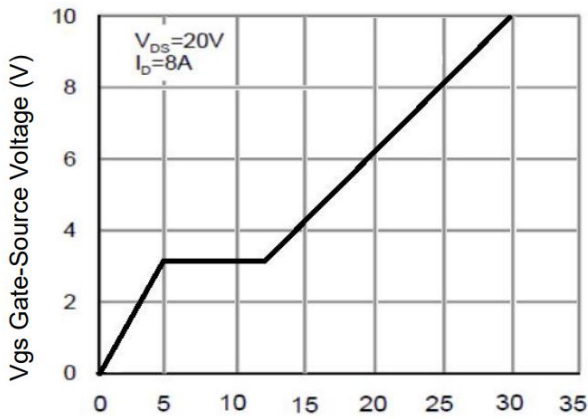

Qg Gate Charge (nC)
Figure 9 Gate Charge

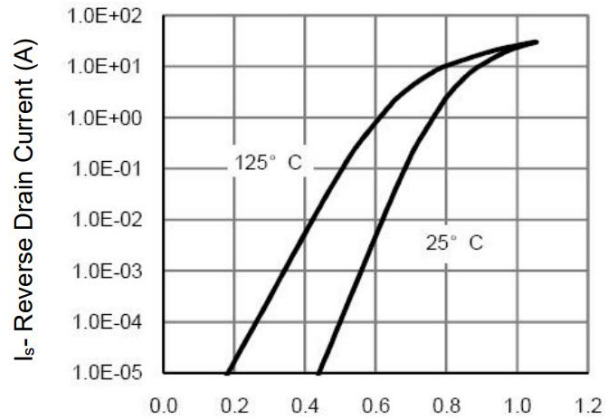

Vds Drain-Source Voltage (V)
Figure 10 Source- Drain Diode Forward

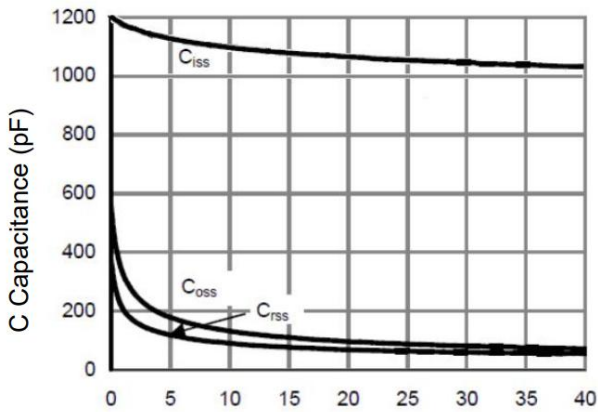

Vds Drain-Source Voltage (V)
Figure 11 Capacitance vs Vds

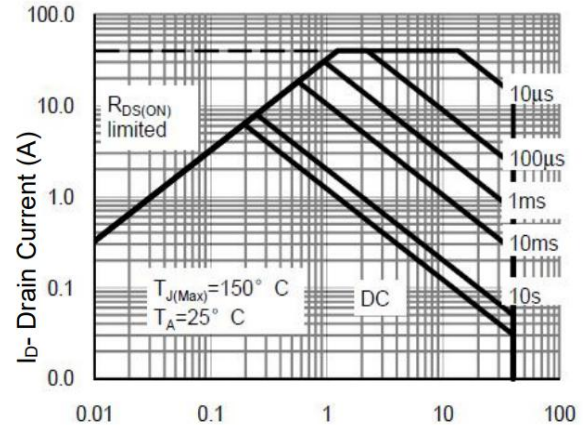

Vds Drain-Source Voltage (V)
Figure 12 Safe Operation Area

N- Channel Typical Characteristics

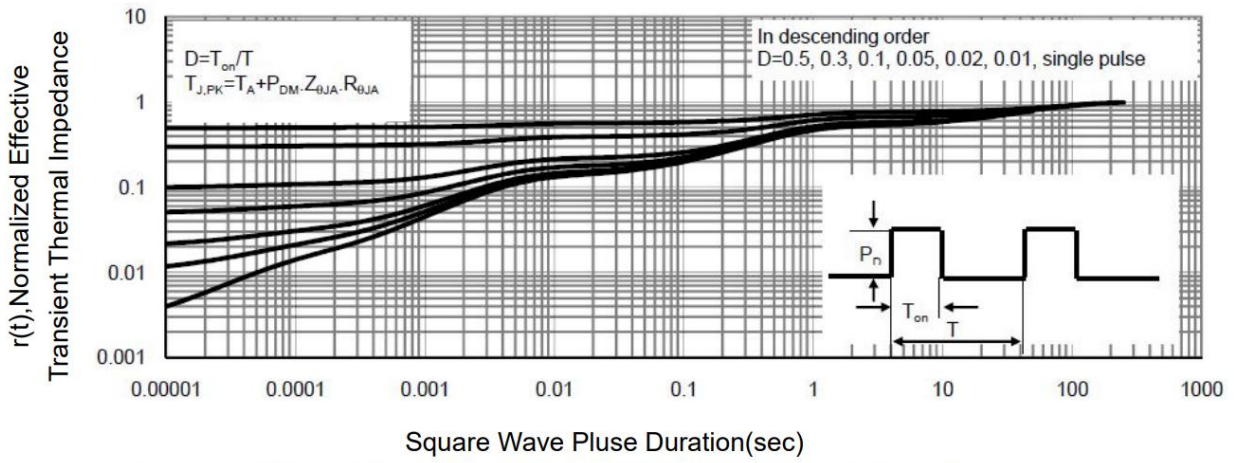

Figure 13 Normalized Maximum Transient Thermal Impedance

P- Channel Typical Characteristics

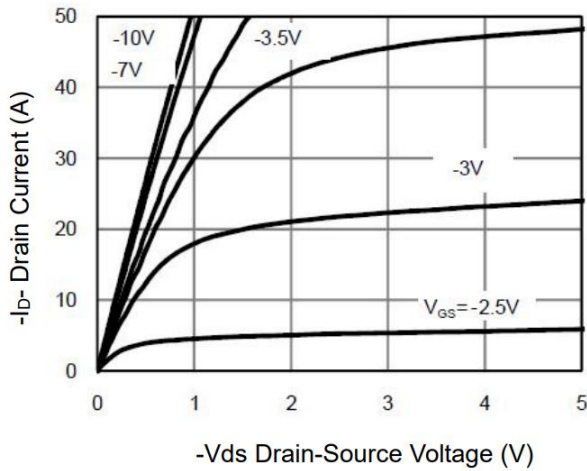

Figure 1 Output Characteristics

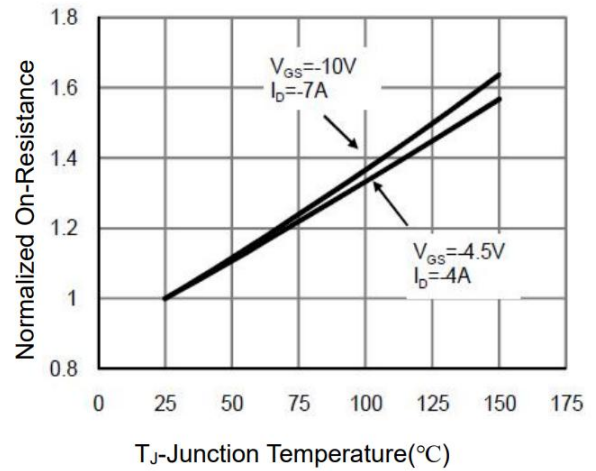

Figure 2 R_{DS(on)}-Junction Temperature

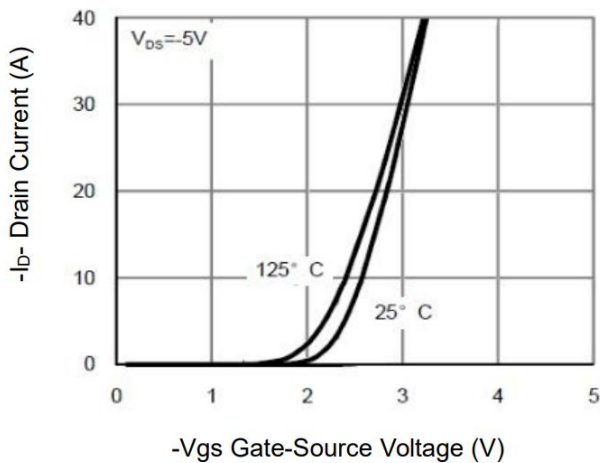

Figure 3 Transfer Characteristics

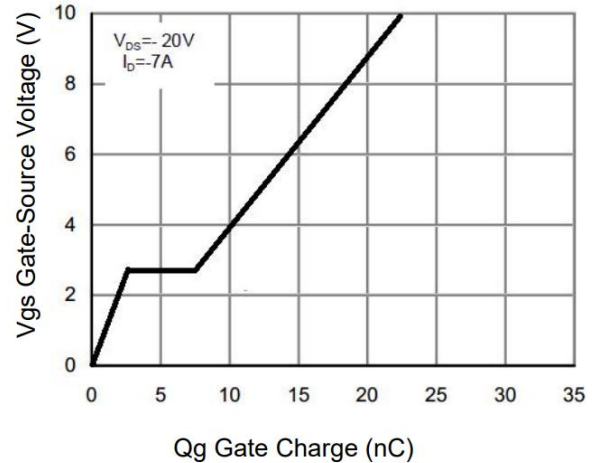

Figure 4 Gate Charge

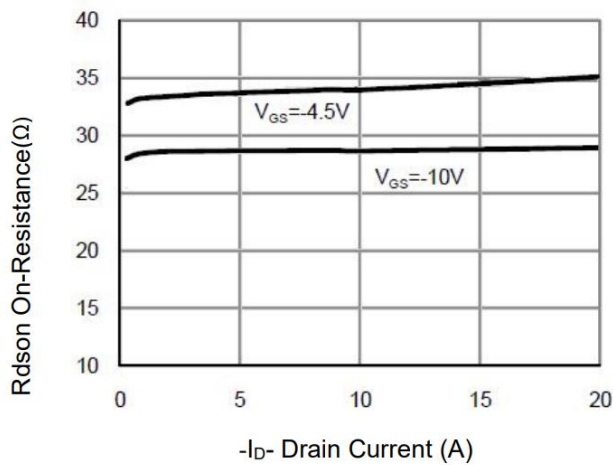

Figure 5 R_{DS(on)}- Drain Current

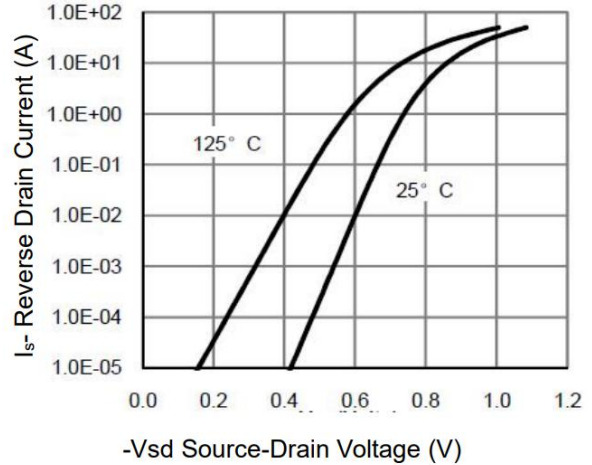

Figure 6 Source- Drain Diode Forward

P- Channel Typical Characteristics

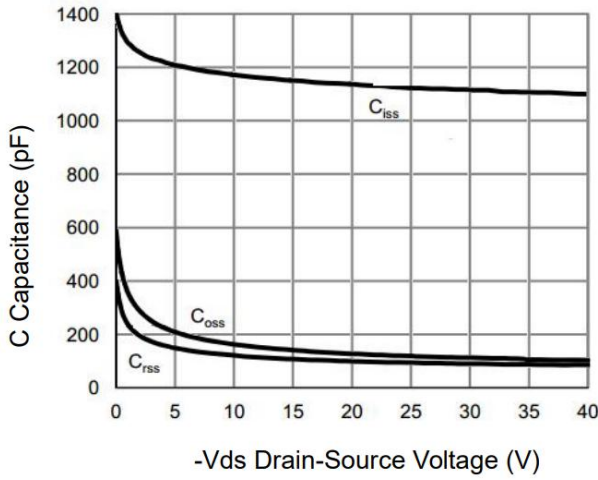

Figure 7 Capacitance vs Vds

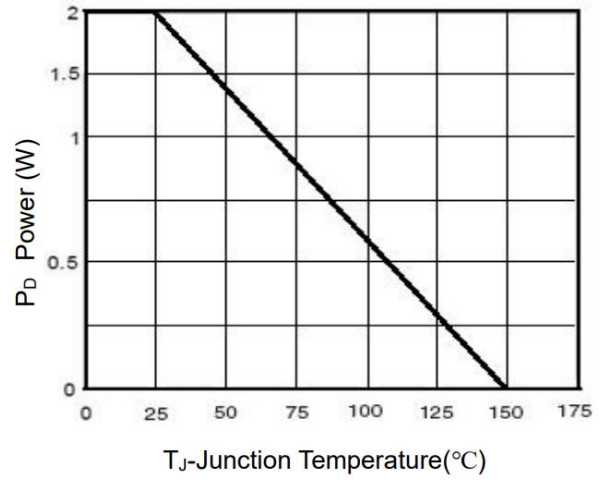

Figure 8 Power Dissipation

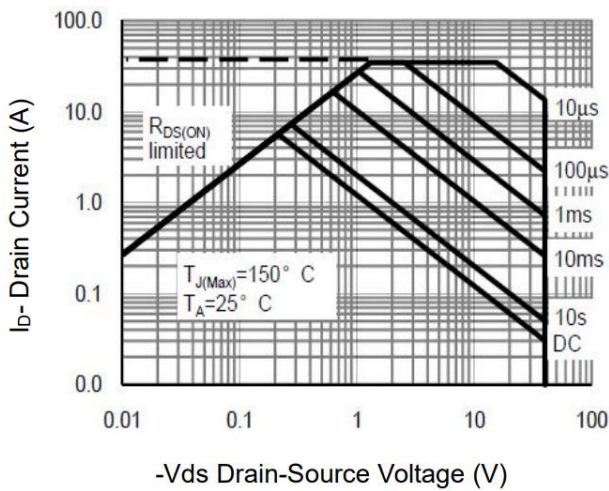

Figure 9 Safe Operation Area

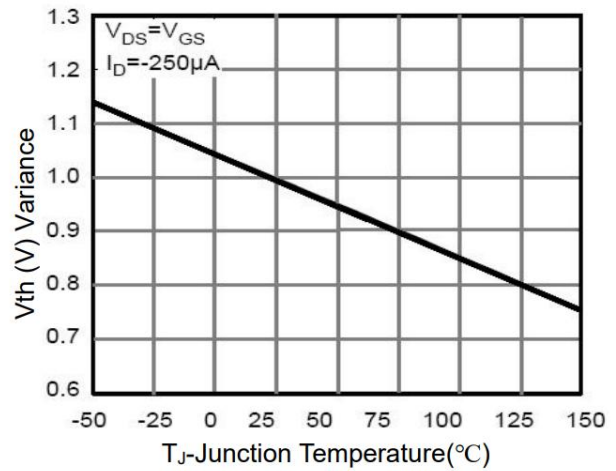

Figure 10 V_{GS(th)} vs Junction Temperature

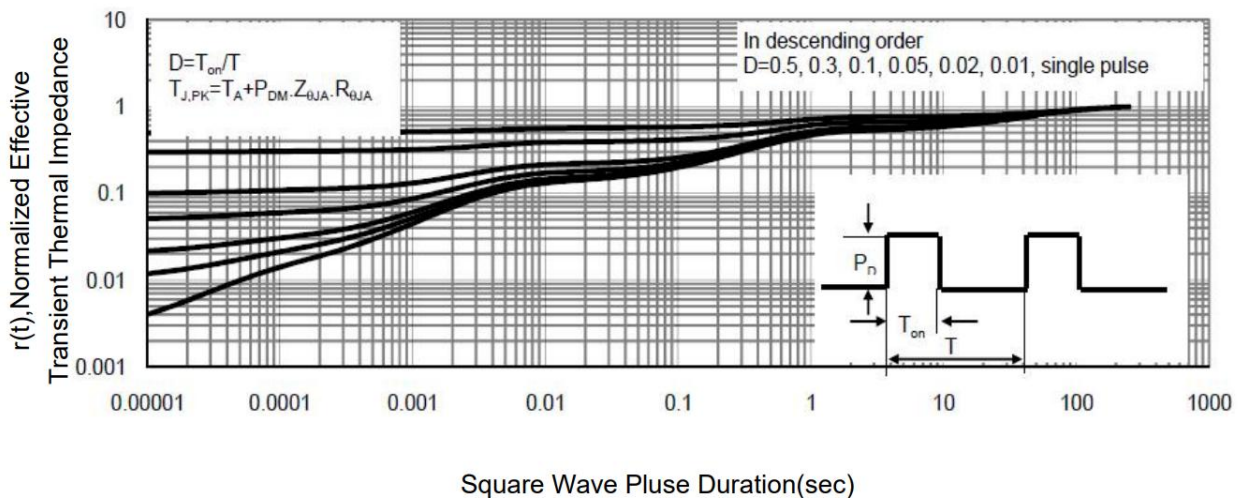
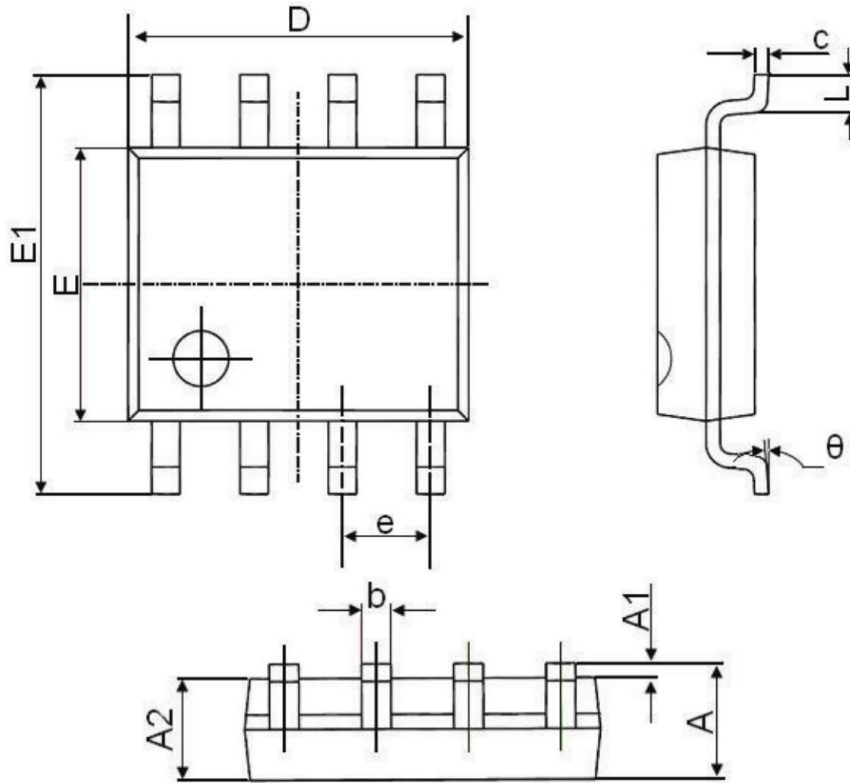

Figure 11 Normalized Maximum Transient Thermal Impedance

SOP-8 Package Information



Symbol	Dimensions In Millimeters		Dimensions In Inches	
	Min.	Max.	Min.	Max.
A	1.350	1.750	0.053	0.069
A1	0.100	0.250	0.004	0.010
A2	1.250	1.650	0.049	0.065
b	0.330	0.510	0.013	0.020
c	0.170	0.250	0.006	0.010
D	4.700	5.100	0.185	0.200
E	3.800	4.000	0.150	0.157
E1	5.800	6.200	0.228	0.244
e	1.270(BSC)		0.050(BSC)	
L	0.400	1.270	0.016	0.050
θ	0°	8°	0°	8°