

### Product Summary

$V_{(BR)DSS}$	$R_{DS(on)MAX}$	$I_D$
120V	6.5mΩ@10V	100A
	7.8mΩ@4.5V	

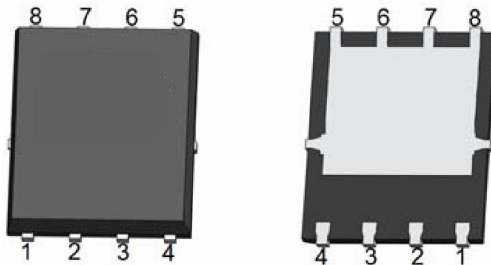
### Feature

- Excellent gate charge x  $R_{DS(on)}$  product (FOM)
- Very low on-resistance  $R_{DS(on)}$
- Suffix "-Q1" for AEC-Q101

### Application

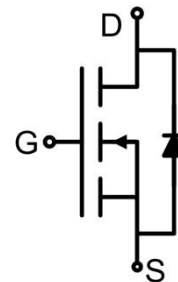
- DC-DC converter
- Ideal for high-frequency switching and synchronous rectification

### Package

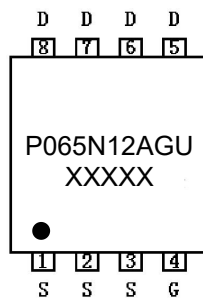


PDFN5\*6-8L

### Circuit diagram



### Marking



### Absolute maximum ratings (T<sub>c</sub>=25°C unless otherwise noted)

Parameter	Symbol	Value	Unit
Drain-Source Voltage	V <sub>DS</sub>	120	V
Gate-Source Voltage	V <sub>GS</sub>	±20	V
Continuous Drain Current	I <sub>D</sub>	100	A
Continuous Drain Current (T <sub>c</sub> =100°C)	I <sub>D</sub> (100°C)	70	A
Pulsed Drain Current	I <sub>DM</sub>	400	A
Power Dissipation	P <sub>D</sub>	130	W
Derating factor	-	1.04	W/°C
Thermal Resistance,Junction-to-Case	R <sub>θJC</sub>	0.96	°C/W
Single pulse avalanche energy <sup>1)</sup>	E <sub>AS</sub>	400	mJ
Junction Temperature	T <sub>J</sub>	150	°C
Storage Temperature	T <sub>STG</sub>	-55 ~ +150	°C

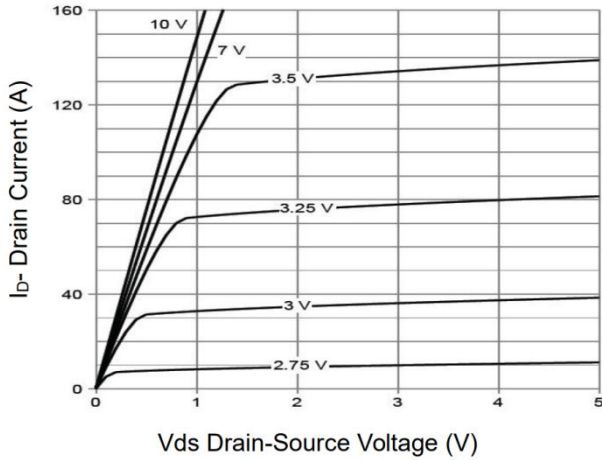
### Electrical characteristics (T<sub>c</sub>=25 °C, unless otherwise noted)

Parameter	Symbol	Test Condition	Min.	Typ.	Max.	Unit
<b>Static Characteristics</b>						
Drain-source breakdown voltage	V <sub>(BR)DSS</sub>	V <sub>GS</sub> = 0V, I <sub>D</sub> =250μA	120			V
Zero gate voltage drain current	I <sub>DSS</sub>	V <sub>DS</sub> =120V, V <sub>GS</sub> = 0V			1	μA
Gate-body leakage current	I <sub>GSS</sub>	V <sub>GS</sub> =±20V, V <sub>DS</sub> = 0V			±100	nA
Gate threshold voltage	V <sub>GS(th)</sub>	V <sub>DS</sub> =V <sub>GS</sub> , I <sub>D</sub> =250μA	1.2	1.8	2.5	V
Drain-source on-resistance	R <sub>DS(on)</sub>	V <sub>GS</sub> =10V, I <sub>D</sub> =45A		5.6	6.5	mΩ
		V <sub>GS</sub> =4.5V, I <sub>D</sub> =45A		6.9	7.8	
Forward Transconductance	g <sub>FS</sub>	V <sub>DS</sub> =5V, I <sub>D</sub> =45A		60		S
<b>Dynamic characteristics<sup>2)</sup></b>						
Input Capacitance	C <sub>iSS</sub>	V <sub>DS</sub> =60V, V <sub>GS</sub> =0V, f =1MHz		4900		pF
Output Capacitance	C <sub>oss</sub>			300		
Reverse Transfer Capacitance	C <sub>rSS</sub>			34		
Total Gate Charge	Q <sub>g</sub>	V <sub>DS</sub> =60V, V <sub>GS</sub> =10V, I <sub>D</sub> =45A		90		nC
Gate-Source Charge	Q <sub>gs</sub>			21		
Gate-Drain Charge	Q <sub>gd</sub>			23.5		
Turn-on delay time	t <sub>d(on)</sub>	V <sub>DD</sub> =60V, V <sub>GS</sub> =10V, I <sub>D</sub> =45A, R <sub>G</sub> =1.6Ω		20		nS
Turn-on rise time	t <sub>r</sub>			15		
Turn-off delay time	t <sub>d(off)</sub>			40		
Turn-off fall time	t <sub>f</sub>			10		
<b>Source-Drain Diode characteristics</b>						
Diode Forward Current	I <sub>S</sub>				100	A
Diode Forward voltage	V <sub>SD</sub>	V <sub>GS</sub> =0V, I <sub>S</sub> =45A			1.2	V
Reverse Recovery Time	t <sub>rr</sub>	T <sub>J</sub> =25°C, I <sub>F</sub> =45A,		70		nS
Reverse Recovery Charge	Q <sub>rr</sub>	di/dt =100A/μs		137		nC

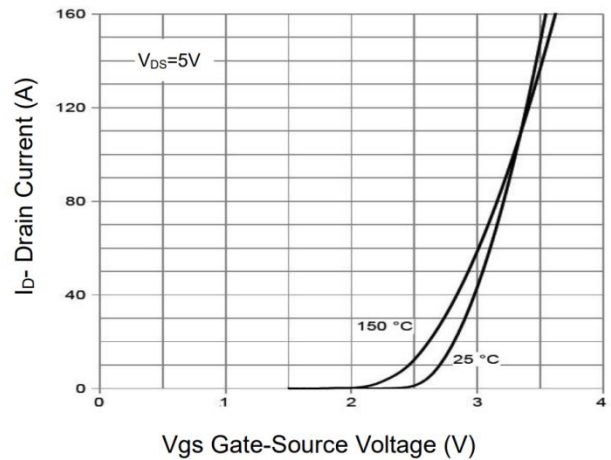
Notes:

- 1) EAS condition : T<sub>J</sub>=25°C, V<sub>DD</sub>=50V, V<sub>G</sub>=10V, L=0.25mH, R<sub>g</sub>=25Ω.
- 2) Guaranteed by design, not subject to production testing.
- 3) These curves are based on the junction-to-case thermal impedance which is measured with the device mounted to a large heatsink, assuming a maximum junction temperature of T<sub>J(MAX)</sub>=150°C. The SOA curve provides a single pulse rating.

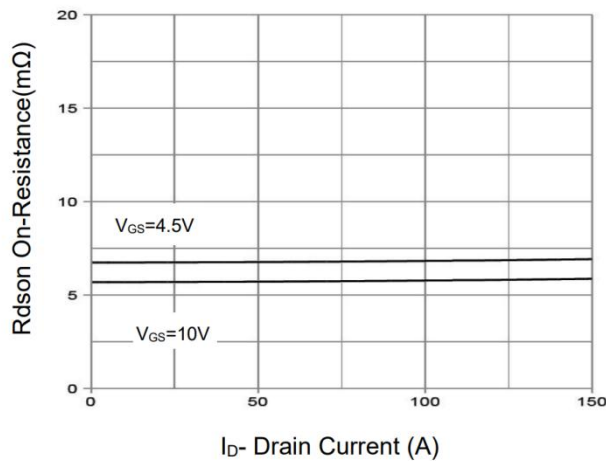
## Typical Characteristics



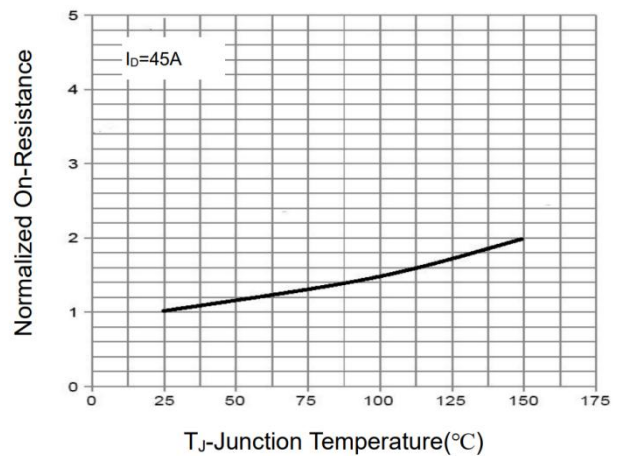
**Figure 1 Output Characteristics**



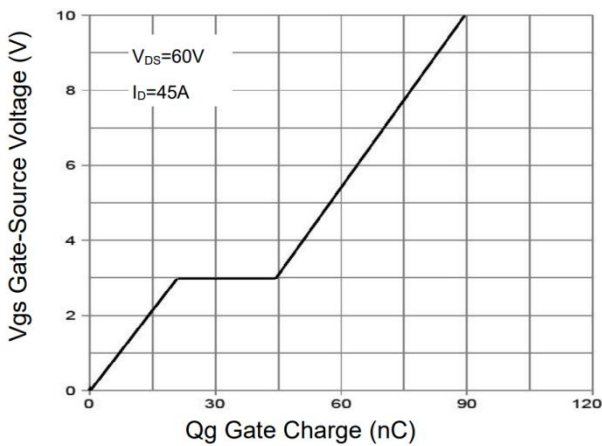
**Figure 2 Transfer Characteristics**



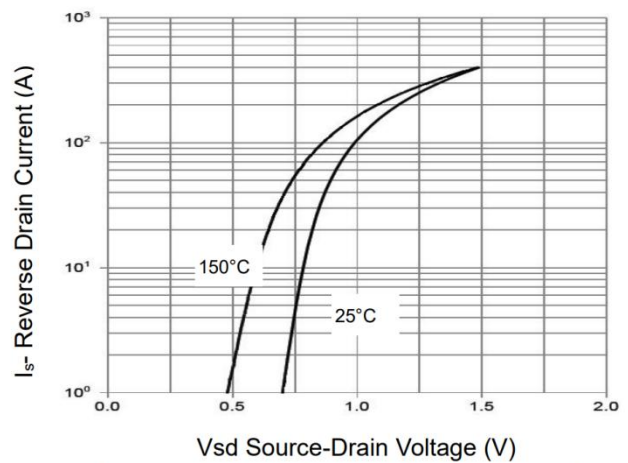
**Figure 3 Rds(on)- Drain Current**



**Figure 4 Rds(on)-Junction Temperature**

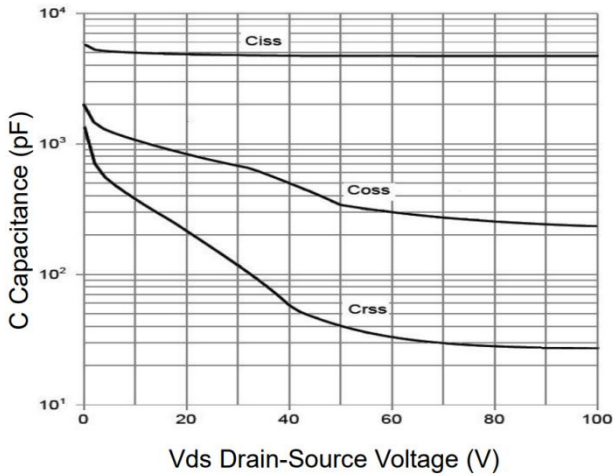


**Figure 5 Gate Charge**

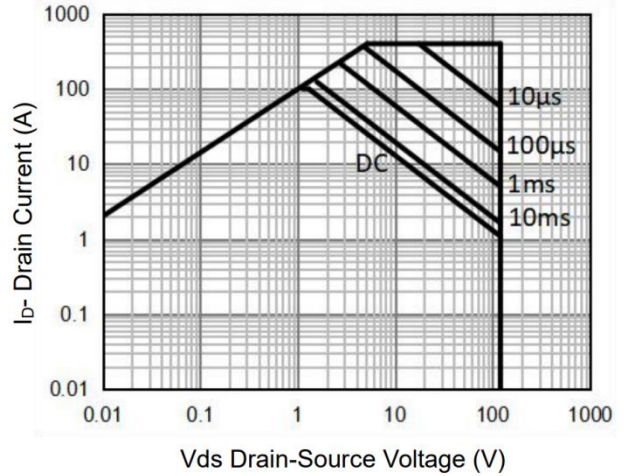


**Figure 6 Source- Drain Diode Forward**

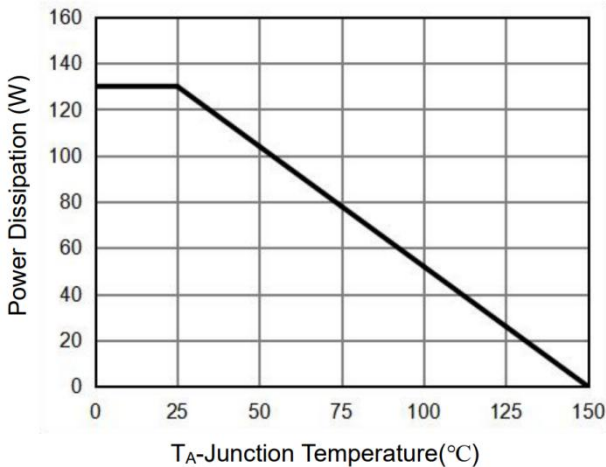
## Typical Characteristics



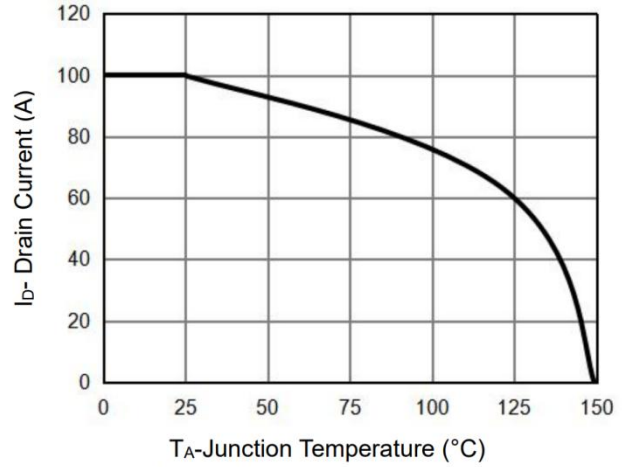
**Figure 7 Capacitance vs Vds**



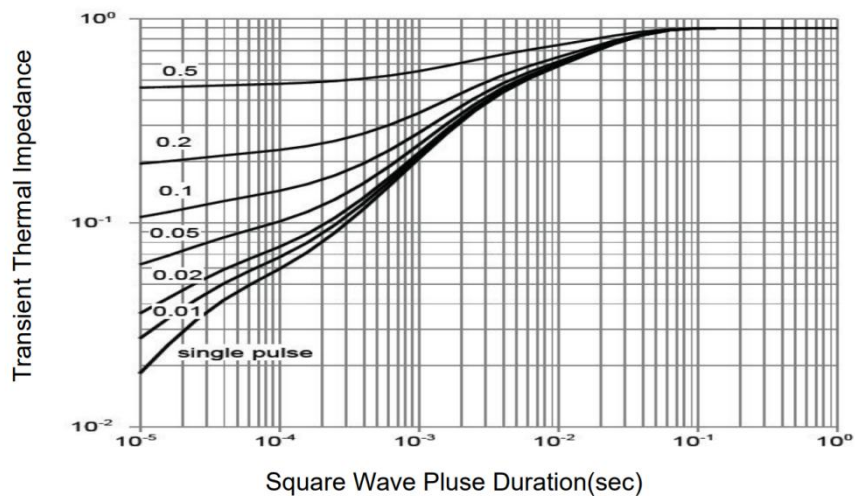
**Figure 8 Safe Operation Area** (Note3)



**Figure 9 Power De-rating**

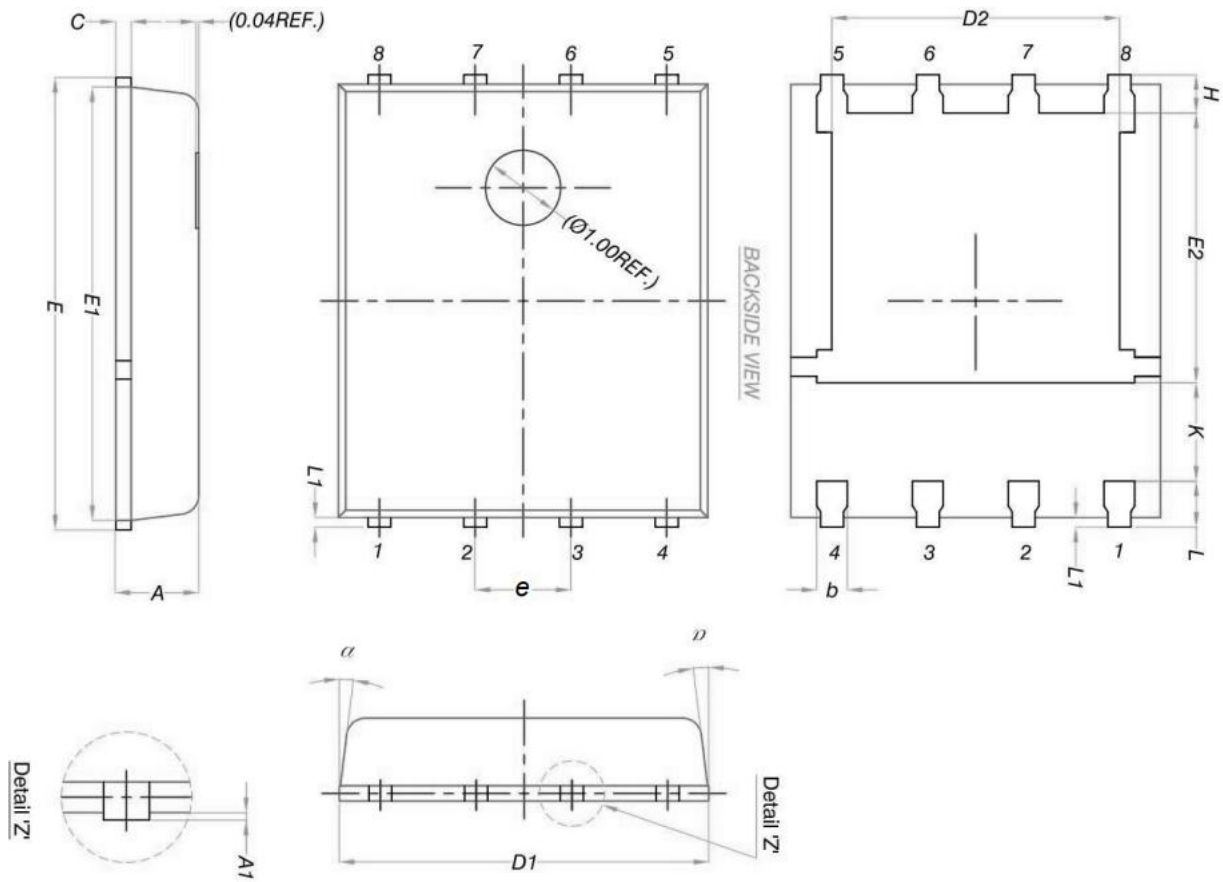


**Figure 10 Current De-rating**



**Figure 11 Normalized Maximum Transient Thermal Impedance**

### PDFN5\*6-8L Package Information



Symbol	Dimensions In Millimeters		Dimensions In Inches	
	Min.	Max.	Min.	Max.
A	0.900	1.100	0.035	0.043
A1	0.000	0.050	0.000	0.002
b	0.330	0.510	0.013	0.020
C	0.200	0.300	0.008	0.012
D1	4.800	5.000	0.189	0.197
D2	3.610	3.960	0.142	0.156
E	5.900	6.100	0.232	0.240
E1	5.700	5.800	0.224	0.228
E2	3.380	3.780	0.133	0.149
e	1.270 BSC		0.050 BSC	
H	0.410	0.610	0.016	0.024
K	1.100	-	0.043	-
L	0.510	0.710	0.020	0.028
L1	0.060	0.200	0.002	0.008
α	0°	12°	0°	12°