

### Features

- Zero or negligible reverse recovery
- Low forward voltage
- Positive temperature coefficient
- Extended surge current capability
- High junction temperature
- Temperature invariant switching behavior

$V_{RRM}$	=	1200	V
$I_F (T_C=152^\circ\text{C})$	=	10	A
$Q_C (V_R=800\text{V})$	=	43.5	nC

### Benefits

- System efficiency improvement over Si diodes
- Higher switching frequency
- Increased power density
- Essentially no switching losses

### Package

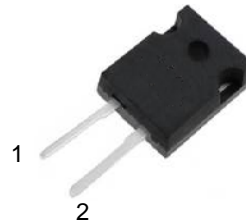

TO-247-2



### Applications

- Solar inverters
- Motor drivers
- Power Factor Correction
- SMPS

Part Number	Package	Marking
ASYD010120C	TO-247-2	ASYD010120C

### Electrical Specifications (T<sub>C</sub>=25°C, unless otherwise specified.)

Symbol	Parameter	Test Condition	Min	Typ	Max	Unit
V <sub>R</sub>	Reverse Blocking Voltage	I <sub>R</sub> =250uA	1200			V
I <sub>R</sub>	Reverse Current	V <sub>R</sub> =1200V T <sub>J</sub> = 25°C T <sub>J</sub> = 175°C		0.1 10	100 200	uA
V <sub>F</sub>	Forward Voltage	I <sub>F</sub> =10A T <sub>J</sub> = 25°C T <sub>J</sub> =175°C		1.5 2.3	1.7 2.7	V

Note: All characteristics are tested with the parts assembled in TO-247-2 package.

### Dynamic Characteristics (T<sub>C</sub>=25°C, unless otherwise specified.)

Symbol	Parameter	Test Condition	Min	Typ	Max	Unit
C <sub>j</sub>	Typical Junction Capacitance	V <sub>R</sub> =0.1 V, f=1 MHz V <sub>R</sub> =400 V, f=1 MHz V <sub>R</sub> =800 V, f=1 MHz		520 42 37		pF
Q <sub>C</sub>	Total Capacitive Charge	V <sub>R</sub> =400V V <sub>R</sub> =800V		28.5 43.5		nC
E <sub>C</sub>	Capacitive Stored Energy,	V <sub>R</sub> =400V V <sub>R</sub> =800V		3.35 11.8		uJ

Note: All characteristics are tested with the parts assembled in TO-247-2 package.

### Thermal Resistances (T<sub>C</sub>=25°C, unless otherwise specified.)

Symbol	Parameter	Test Condition	Min	Typ	Max	Unit
R <sub>th(j-c)</sub>	Thermal Resistance, Junction – Case			0.875	0.91	°C/W
R <sub>th(j-a)</sub>	Thermal Resistance, Junction –Ambient			35.5		°C/W

Note: All characteristics are tested with the parts assembled in TO-247-2 package.

### Absolute Maximum Ratings (T<sub>C</sub>=25°C, unless otherwise specified.)

Symbol	Parameter	Rating
V <sub>RRM</sub>	Repetitive Peak Reverse Voltage	1200V
I <sub>F</sub>	Continuous Forward Current T <sub>C</sub> =25 °C, D=1 T <sub>C</sub> =100 °C, D=1 T <sub>C</sub> =152 °C, D=1	27.7 A 19.7 A 10 A
I <sub>FSM</sub>	Non-Repetitive Forward Surge Current T <sub>C</sub> =25 °C, t <sub>p</sub> =10ms T <sub>C</sub> =125 °C, t <sub>p</sub> =10ms	99.5 A 70 A
I <sub>FRM</sub>	Repetitive Forward Surge Current T <sub>C</sub> =25 °C, t <sub>p</sub> =10ms T <sub>C</sub> =125 °C, t <sub>p</sub> =10ms	43 A 24.5 A
P <sub>TOT</sub>	Power dissipation for R <sub>th(j-c,max)</sub> , T <sub>C</sub> =25 °C	165 W
T <sub>j</sub> , T <sub>stg</sub>	Operating and Storage Temperature	-55°C to 175°C

Note: All characteristics are tested with the parts assembled in TO-247-2 package , and exposure to absolute maximum ratings for prolonged time periods may affect device reliability.

## Typical Performance

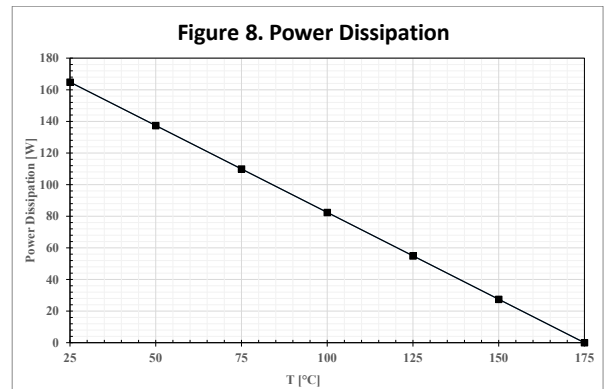
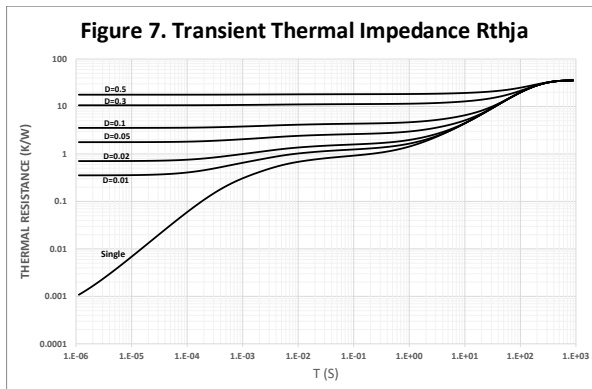
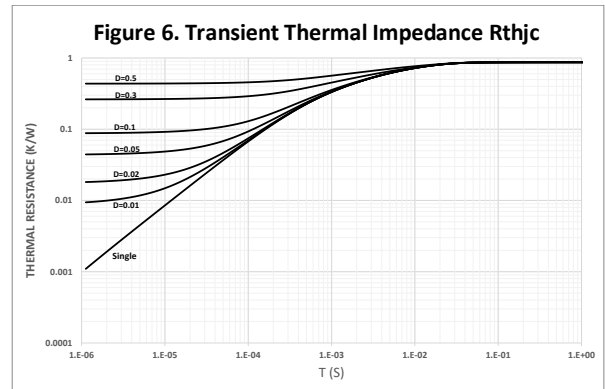
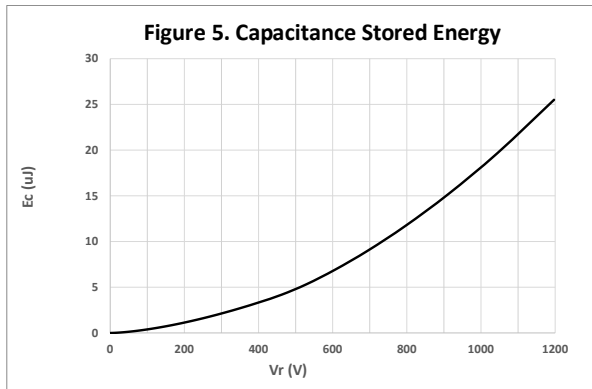
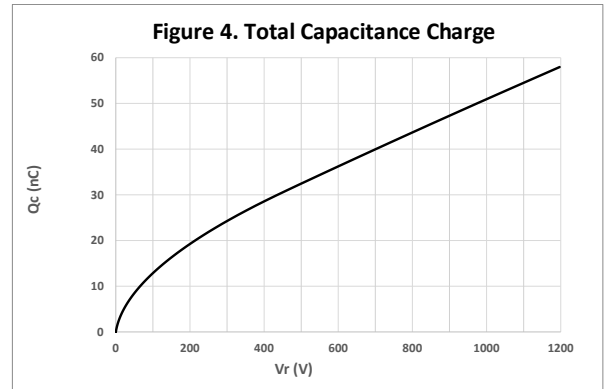
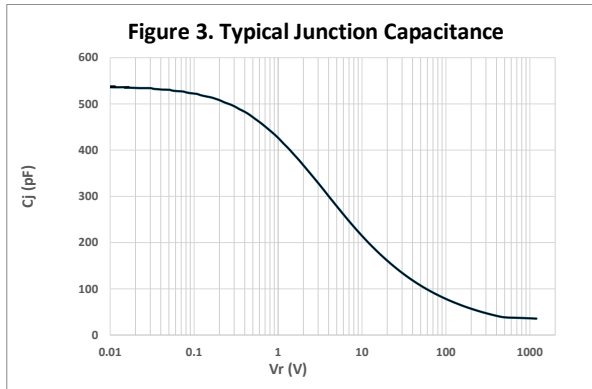
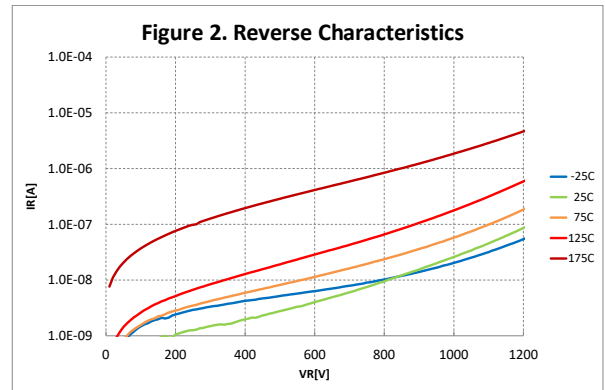
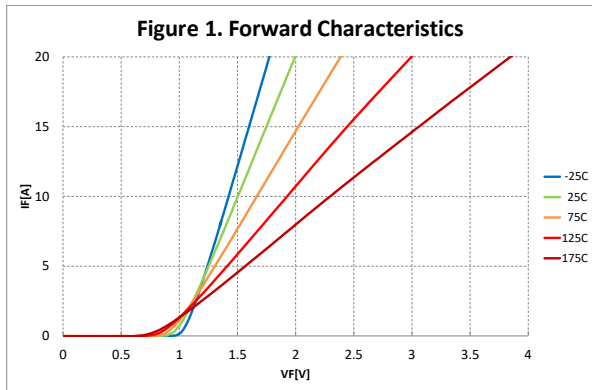

### Package Dimensions

Package TO-247-2

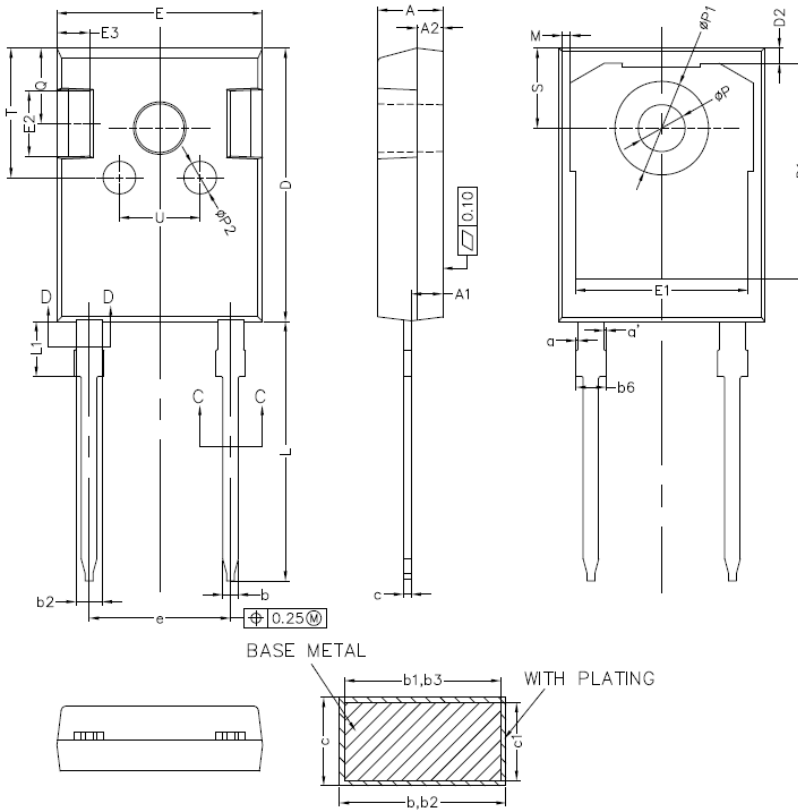

COMMON DIMENSIONS  
(UNITS OF MEASURE=MILLIMETER)

SYMBOL	MIN	NOM	MAX
A	4.90	5.00	5.10
A1	2.31	2.41	2.51
A2	1.90	2.00	2.10
a	0	-	0.15
a'	0	-	0.15
b	1.16	-	1.29
b1	1.15	1.20	1.25
b2	1.96	-	2.06
b3	1.95	2.00	2.02
b6	-	-	2.25
c	0.59	-	0.66
c1	0.58	0.60	0.62
D	20.90	21.00	21.10
D1	16.25	16.55	16.85
D2	1.05	1.20	1.35
E	15.70	15.80	15.90
E1	13.06	13.26	13.46
E2	4.90	5.00	5.10
E3	2.40	2.50	2.60
e	10.78	10.88	10.98
L	19.80	19.92	20.10
L1	3.93	-	4.46
M	0.35	-	0.95
P	3.50	3.60	3.70
P1	7.00	-	7.40
P2	2.40	2.50	2.60
Q	5.60	-	6.00
S	6.05	6.15	6.25
T	9.80	-	10.20
U	6.00	-	6.40

NOTES:  
 1. ALL DIMENSIONS REFER TO JEDEC STANDARD TO-247 AD DO NOT INCLUDE MOLD FLASH OR PROTRUSIONS.  
 2. EJECTION MARK DEPTH 0.10±0.15