

Product Summary

$V_{(BR)DSS}$	$R_{DS(on)MAX}$	I_b
60V	29mΩ@10V	23A
	49mΩ@4.5V	

Feature

- Excellent package for heat dissipation
- High density cell design for low $R_{DS(ON)}$
- Suffix “-Q1” for AEC-Q101

Application

- Power switching application
- Uninterruptible power supply
- DC-DC convertor

Package

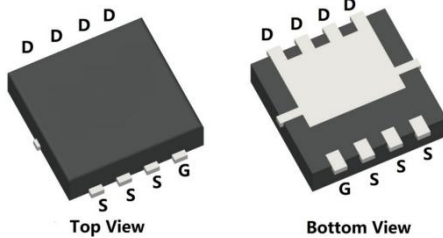

PDFN3.3*3.3-8L

Circuit diagram

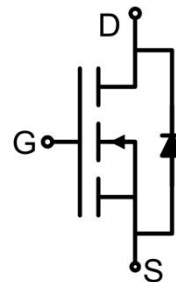

Marking

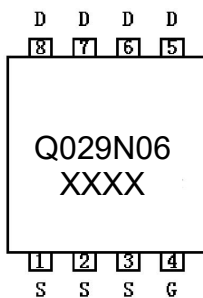

Absolute maximum ratings ($T_J=25^\circ\text{C}$ unless otherwise noted)

Parameter	Symbol	Value	Unit
Drain-Source Voltage	V_{DS}	60	V
Gate-Source Voltage	V_{GS}	± 20	V
Continuous Drain Current ^{1,3)} ($T_C=25^\circ\text{C}$)	I_D	23	A
Continuous Drain Current ^{1,3)} ($T_C=100^\circ\text{C}$)	$I_D(100^\circ\text{C})$	16	A
Pulsed Drain Current ($T_C=25^\circ\text{C}$, $t_p=100\mu\text{s}$)	I_{DM}	65	A
Single Pulse Avalanche Energy ²⁾	E_{AS}	31.9	mJ
Power Dissipation ^{1,3)}	P_D	45	W
Thermal Resistance Junction to Case	$R_{\theta JC}$	3.3	$^\circ\text{C}/\text{W}$
Operating Junction Temperature	T_J	-55 ~ +175	$^\circ\text{C}$
Storage Temperature	T_{STG}	-55 ~ +175	$^\circ\text{C}$

Electrical characteristics ($T_J=25^\circ\text{C}$, unless otherwise noted)

Parameter	Symbol	Test Condition	Min.	Typ.	Max.	Unit
Static Characteristics						
Drain-source breakdown voltage	$V_{(BR)DSS}$	$V_{GS}=0\text{V}$, $I_D=250\mu\text{A}$	60			V
Zero gate voltage drain current	I_{DSS}	$V_{DS}=60\text{V}$, $V_{GS}=0\text{V}$			1	μA
Gate-body leakage current	I_{GSS}	$V_{DS}=0\text{V}$, $V_{GS}=\pm 20\text{V}$			± 100	nA
Gate threshold voltage	$V_{GS(th)}$	$V_{DS}=V_{GS}$, $I_D=250\mu\text{A}$	1.5	2	2.5	V
Drain-source on-resistance	$R_{DS(on)}$	$V_{GS}=10\text{V}$, $I_D=20\text{A}$		23	29	m Ω
		$V_{GS}=4.5\text{V}$, $I_D=10\text{A}$		36	49	
Dynamic characteristics⁴⁾						
Input Capacitance	C_{iss}	$V_{DS}=30\text{V}$, $V_{GS}=0\text{V}$, $f=1\text{MHz}$		920		pF
Output Capacitance	C_{oss}			65		
Reverse Transfer Capacitance	C_{rss}			53		
Total Gate Charge	Q_g	$V_{DS}=30\text{V}$, $V_{GS}=10\text{V}$, $I_D=20\text{A}$		18		nC
Gate-Source Charge	Q_{gs}			2.8		
Gate-Drain Charge	Q_{gd}			2.4		
Turn-on delay time	$t_{d(on)}$	$V_{DS}=30\text{V}$, $V_{GS}=10\text{V}$, $I_D=20\text{A}$ $R_G=2.7\Omega$		9.3		nS
Turn-on rise time	t_r			48.5		
Turn-off delay time	$t_{d(off)}$			19.4		
Turn-off fall time	t_f			4.6		
Source-Drain Diode characteristics						
Diode Forward Current	I_S				23	A
Diode Forward voltage	V_{SD}	$V_{GS}=0\text{V}$, $I_S=20\text{A}$			1.2	V
Reverse Recovery Time	T_{rr}	$I_F=20\text{A}$, $di/dt=-100\text{A}/\mu\text{s}$		18.7		nS
Reverse Recovery Charge	Q_{rr}			15.3		nC

Notes:

1) The entire application environment impacts the thermal resistance values shown, they are not constants and are only valid for the particular conditions noted.

2) $T_J=25^\circ\text{C}$, $V_G=10\text{V}$, $R_G=25\Omega$, $L=0.5\text{mH}$, $I_{AS}=11.3\text{A}$.

3) Thermal resistance from junction to soldering point (on the exposed drain pad).

4) Guaranteed by design, not subject to production.

Typical Characteristics

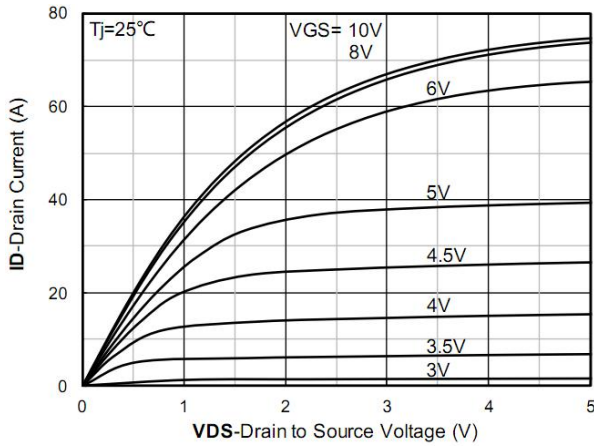

Figure 1. Output Characteristics

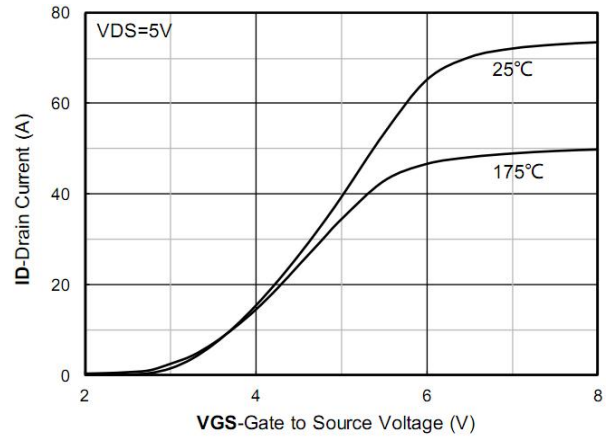

Figure 2. Transfer Characteristics

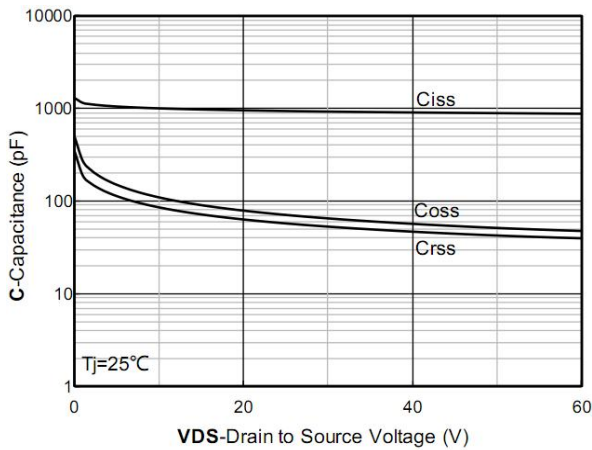

Figure 3. Capacitance Characteristics

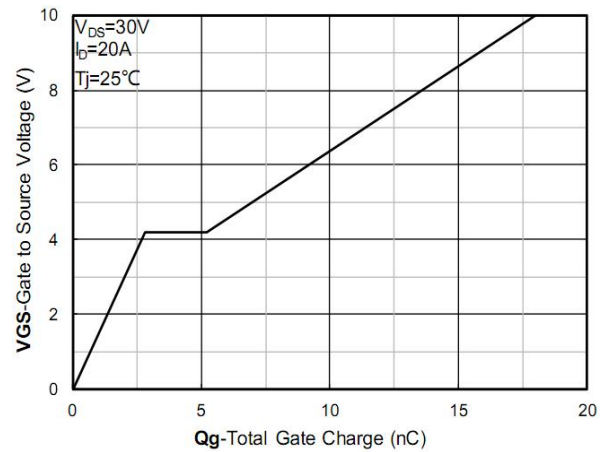

Figure 4. Gate Charge; typical values

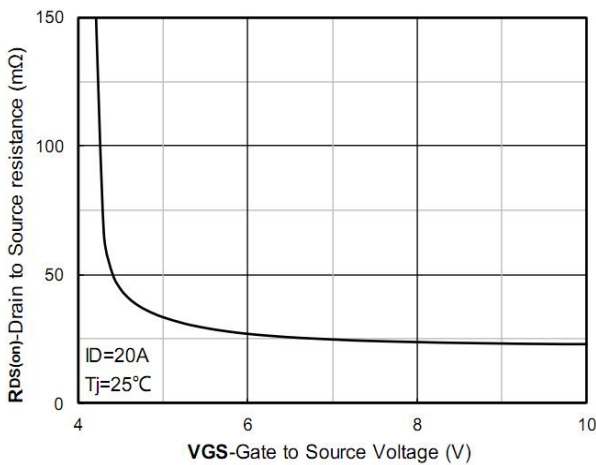

Figure 5. On-Resistance vs Gate to Source Voltage

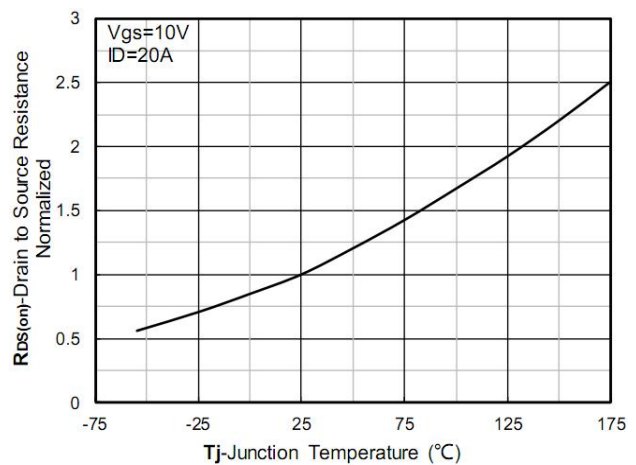

Figure 6. Normalized On-Resistance

Typical Characteristics

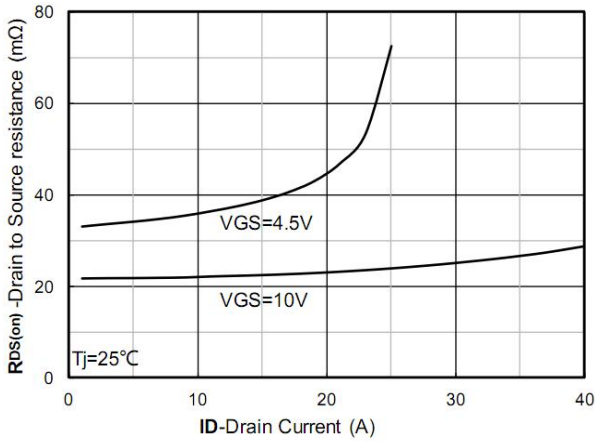

Figure 7. RDS(on) VS Drain Current

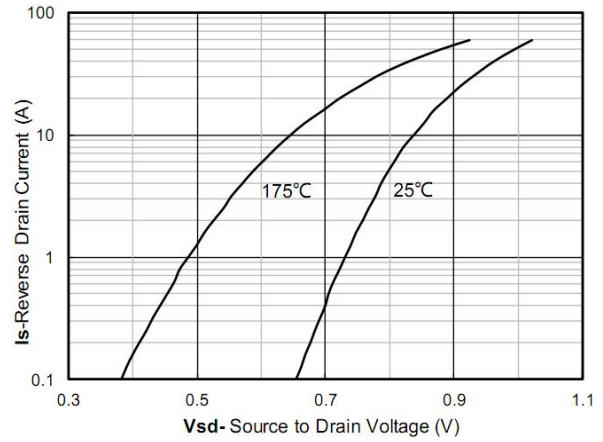

Figure 8. Forward characteristics of reverse diode

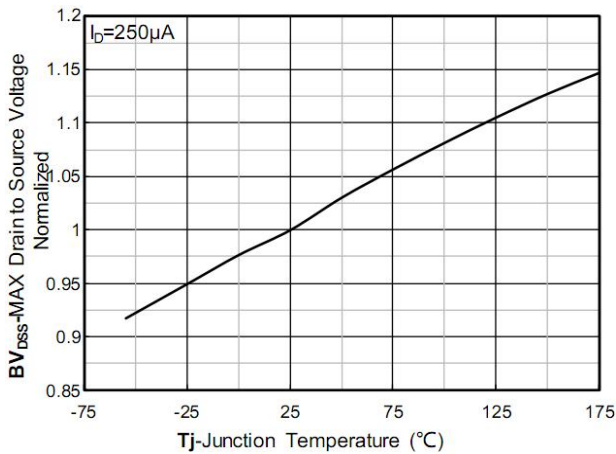

Figure 9. Normalized breakdown voltage

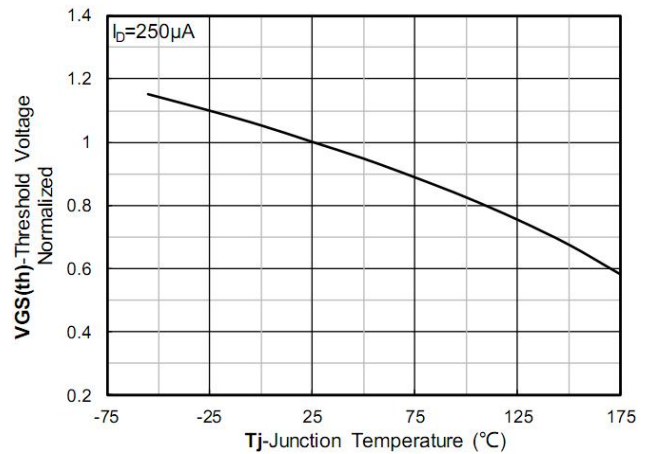

Figure 10. Normalized Threshold voltage

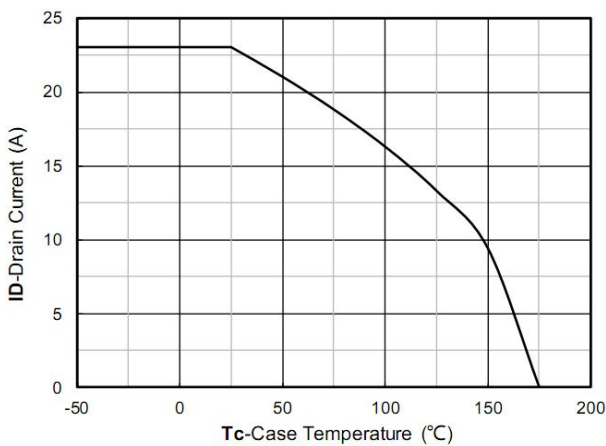

Figure 11. Current dissipation

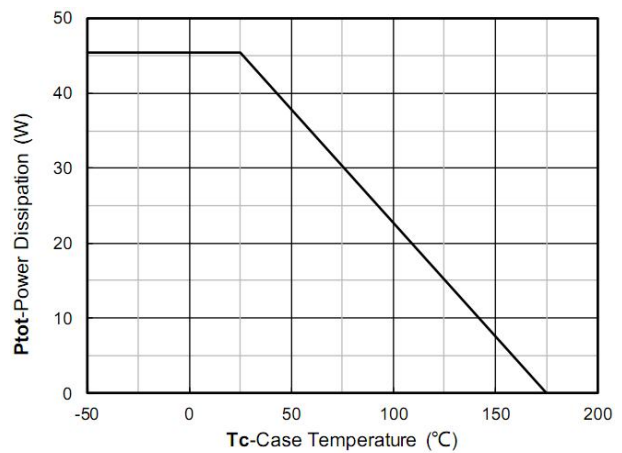

Figure 12. Power dissipation

Typical Characteristics

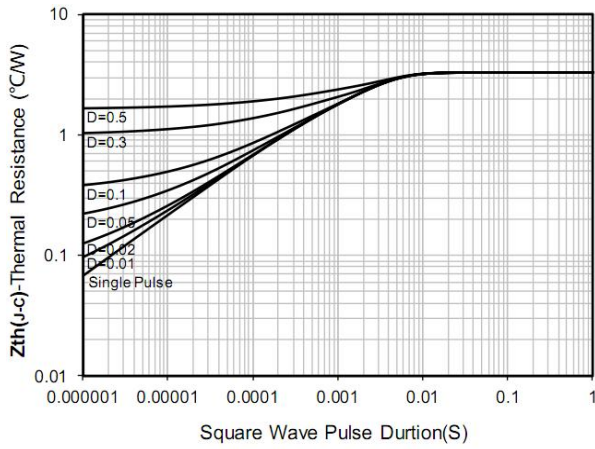

Figure 13. Maximum Transient Thermal Impedance

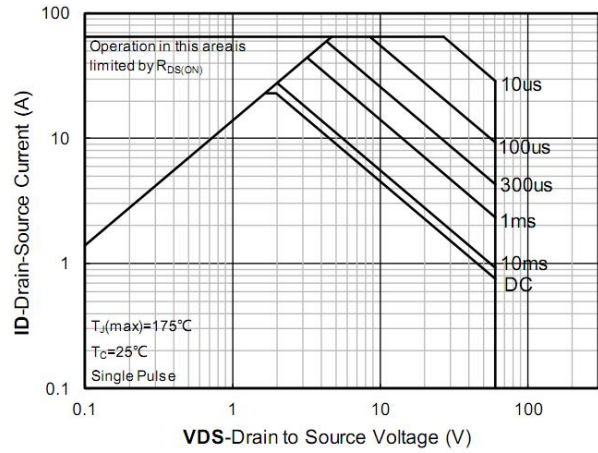
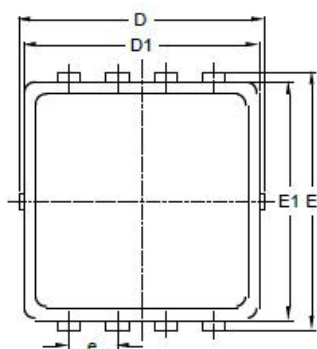
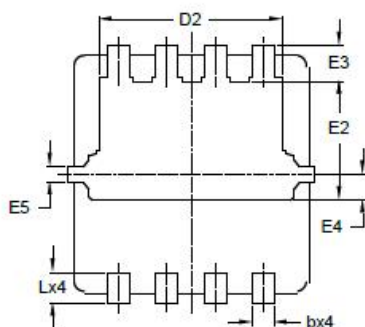

Figure 14. Safe Operation Area

PDFN3.3*3.3-8L Package Information



TOP VIEW



BOTTOM VIEW

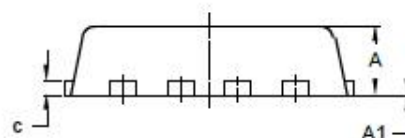

SIDE VIEW

Symbol	Dimensions In Millimeters		Dimensions In Inches	
	Min.	Max.	Min.	Max.
A	0.700	0.850	0.028	0.033
A1	0.000	0.050	0.000	0.002
b	0.200	0.400	0.008	0.016
c	0.100	0.250	0.004	0.010
D	3.150	3.450	0.124	0.136
D1	3.000	3.300	0.118	0.130
D2	2.250	2.650	0.089	0.104
E	3.150	3.450	0.124	0.136
E1	2.900	3.200	0.114	0.126
E2	1.320	1.720	0.052	0.068
E3	0.280	0.650	0.011	0.026
E4	0.330 REF.		0.013 REF.	
E5	0.200 REF.		0.008 REF.	
e	0.650 BSC.		0.026 BSC.	
L	0.300	0.500	0.012	0.020