

Product Summary

$V_{(BR)DSS}$	$R_{DS(on)MAX}$	I_D
-40V	9.9mΩ@-10V	-62A
	14mΩ@-4.5V	

Feature

- Low $R_{DS(on)}$
- Surface-mounted package
- Suffix “-Q1” for AEC-Q101

Application

- Load switch
- Power management
- PWM application

Package

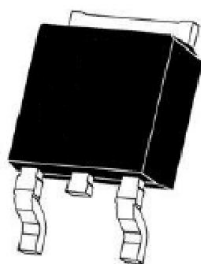

TO-252AB

Circuit diagram

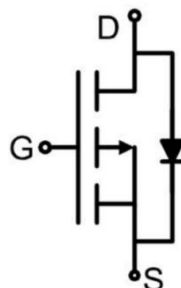

Marking

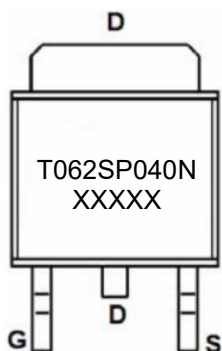

Absolute maximum ratings ($T_A=25^\circ\text{C}$ unless otherwise noted)

Parameter	Symbol	Value	Unit
Drain-Source Voltage	V_{DS}	-40	V
Gate-Source Voltage	V_{GS}	± 20	V
Continuous Drain Current ($T_C=25^\circ\text{C}$)	I_D	-62	A
Continuous Drain Current ($T_C=100^\circ\text{C}$)	$I_D(100^\circ\text{C})$	-39	A
Pulsed Drain Current ¹⁾	I_{DM}	-248	A
Single Pulse Avalanche Energy ²⁾	E_{AS}	167	mJ
Power Dissipation ($T_C=25^\circ\text{C}$)	P_D	56	W
Thermal Resistance Junction to Case	$R_{\theta JC}$	2.2	$^\circ\text{C}/\text{W}$
Operating Junction Temperature	T_J	-55 ~ +150	$^\circ\text{C}$
Storage Temperature	T_{STG}	-55 ~ +150	$^\circ\text{C}$

Electrical characteristics ($T_A=25^\circ\text{C}$ unless otherwise noted)

Parameter	Symbol	Test Condition	Min.	Typ.	Max.	Unit
Static Characteristics						
Drain-source breakdown voltage	$V_{(BR)DSS}$	$V_{GS}=0\text{V}, I_D=-250\mu\text{A}$	-40			V
Zero gate voltage drain current	I_{DSS}	$V_{DS}=-40\text{V}, V_{GS}=0\text{V}$			-1	μA
Gate-body leakage current	I_{GSS}	$V_{DS}=0\text{V}, V_{GS}=\pm 20\text{V}$			± 100	nA
Gate threshold voltage	$V_{GS(th)}$	$V_{DS}=V_{GS}, I_D=-250\mu\text{A}$	-1	-1.5	-2.2	V
Drain-source on-resistance	$R_{DS(on)}$	$V_{GS}=-10\text{V}, I_D=-15\text{A}$		7.8	9.9	m Ω
		$V_{GS}=-4.5\text{V}, I_D=-10\text{A}$			14	
Dynamic characteristics³⁾						
Input Capacitance	C_{iss}	$V_{DS}=-20\text{V}, V_{GS}=0\text{V}, f=1\text{MHz}$		2874		pF
Output Capacitance	C_{oss}			326		
Reverse Transfer Capacitance	C_{rss}			222		
Total Gate Charge	Q_g	$V_{DS}=-20\text{V}, V_{GS}=-10\text{V}, I_D=-15\text{A}$		57		nC
Gate-Source Charge	Q_{gs}			9.5		
Gate-Drain Charge	Q_{gd}			13		
Turn-on delay time	$t_{d(on)}$	$V_{DS}=-20\text{V}, V_{GS}=-10\text{V}, I_D=-15\text{A}, R_G=3.3\Omega$		11		nS
Turn-on rise time	t_r			36		
Turn-off delay time	$t_{d(off)}$			86		
Turn-off fall time	t_f			22.5		
Source-Drain Diode characteristics						
Diode Forward Current	I_S				-62	A
Diode Forward Voltage	V_{SD}	$V_{GS}=0\text{V}, I_S=-1\text{A}$			-1	V
Reverse Recovery Time	T_{rr}	$I_F=-15\text{A}, di/dt=-100\text{A}/\mu\text{s}$		26		nS
Reverse Recovery Charge	Q_{rr}			24		nC

Notes:

- 1) Pulse Test: Pulse Width $\leq 100\mu\text{s}$, Duty Cycle $\leq 2\%$, Repetitive rating, pulse width limited by junction temperature $T_{J(MAX)} = 150^\circ\text{C}$.
- 2) Limited by $T_{J(MAX)}$, starting $T_J = 25^\circ\text{C}$, $L = 0.5\text{mH}$, $R_G = 25\Omega$, $I_{AS} = -25.9\text{A}$, $V_{GS} = -10\text{V}$.
- 3) Guaranteed by design, not subject to production testing.

Typical Characteristics

Fig. 1 Typical Output Characteristics

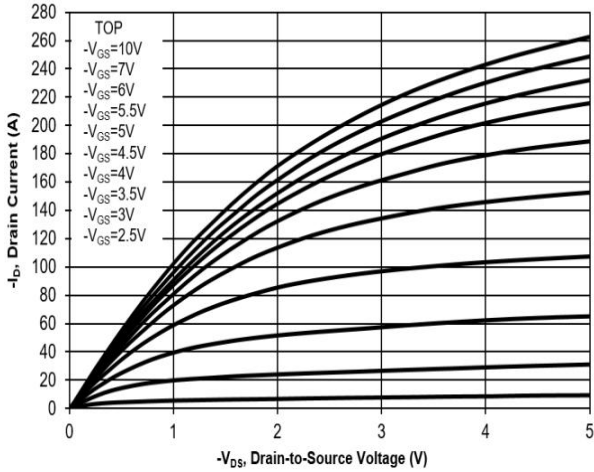

Fig. 2 Typical Transfer Characteristics

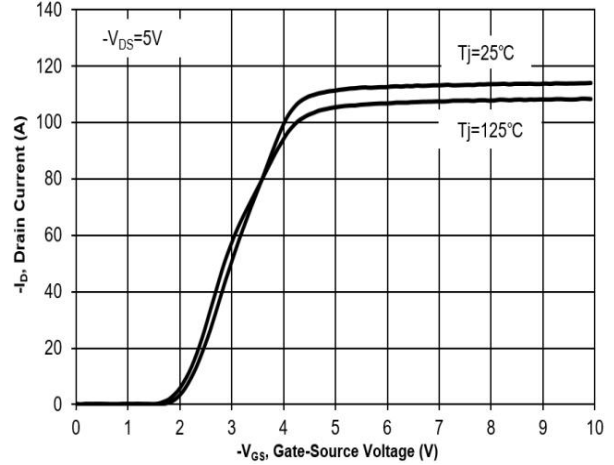

Fig. 3 On-Resistance vs. Drain Current

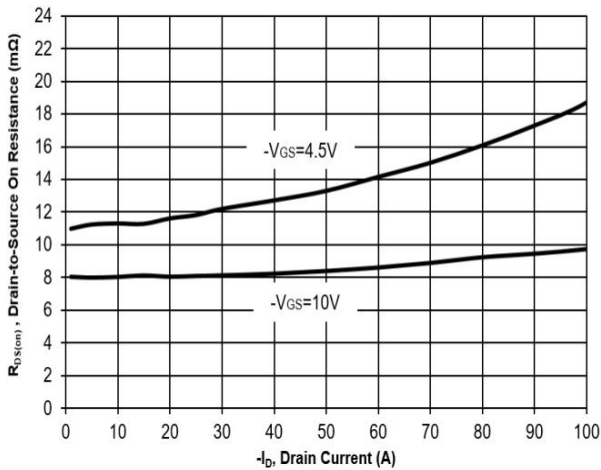

Fig. 4 On-Resistance vs. Gate to Source Voltage

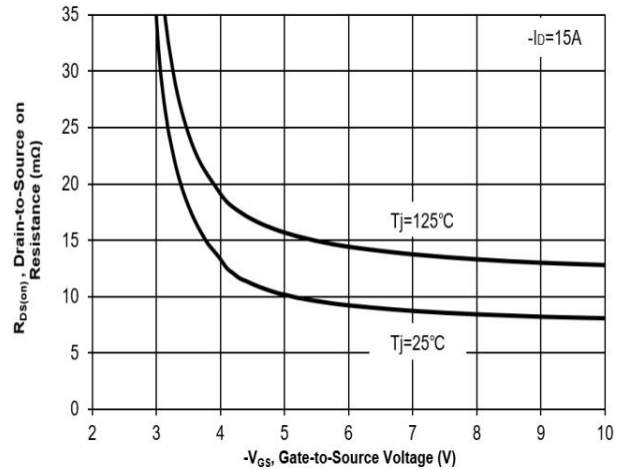

Fig. 5 On-Resistance vs. Tj

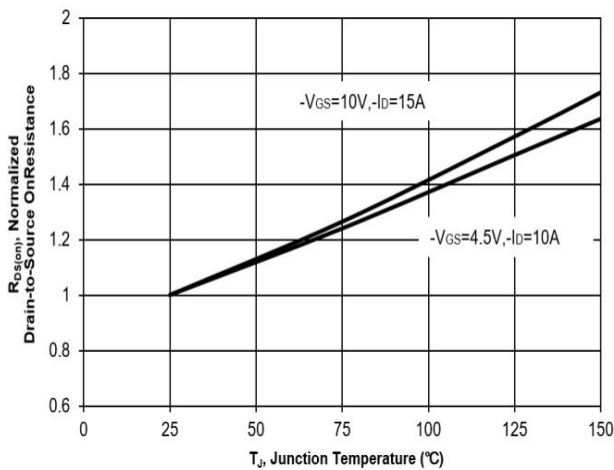
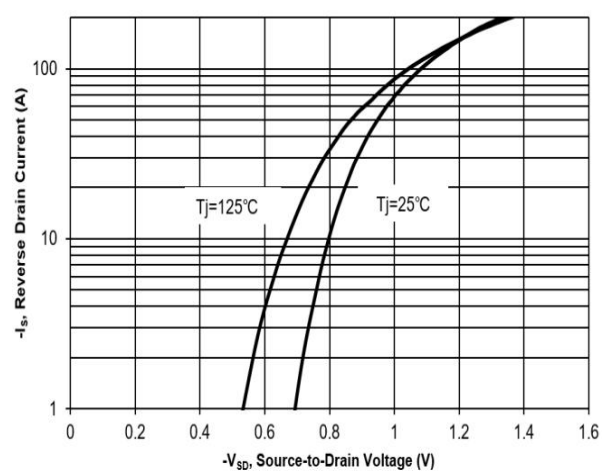

Fig. 6 Typical Body-Diode Forward Characteristics



Typical Characteristics

Fig. 7 Typical Junction Capacitance

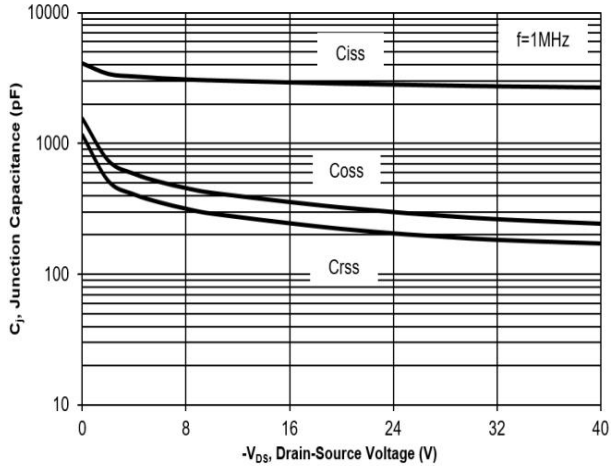

Fig. 8 Drain-Source Leakage Current vs. T_j

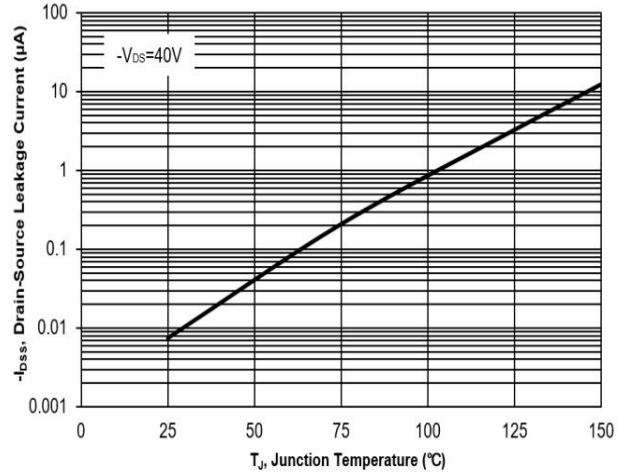

Fig. 9 V_{(BR)DSS} vs. Junction Temperature

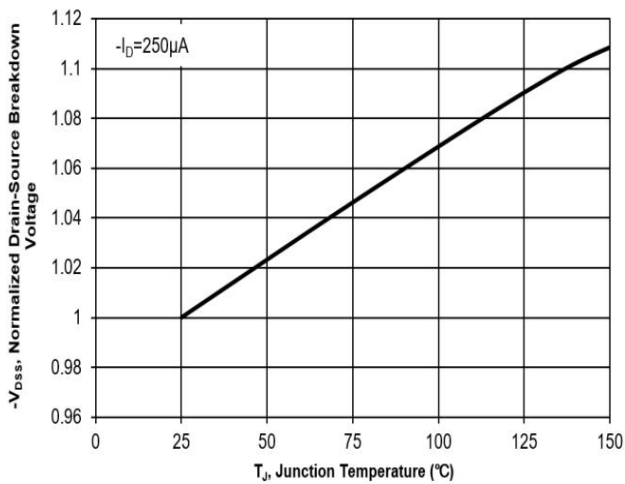

Fig. 10 Gate Threshold Variation vs. T_j

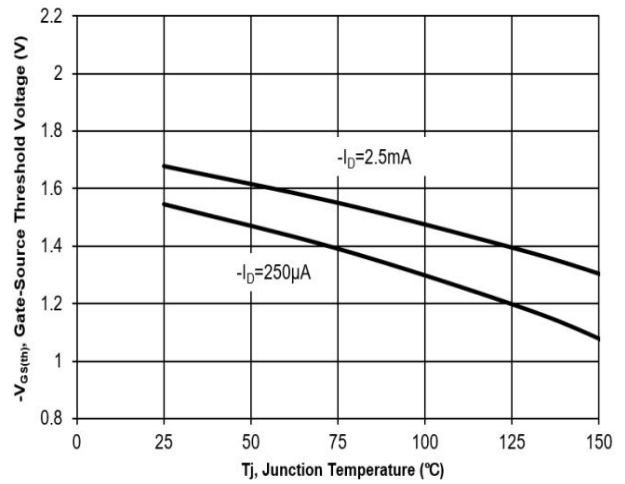

Fig. 11 Gate Charge

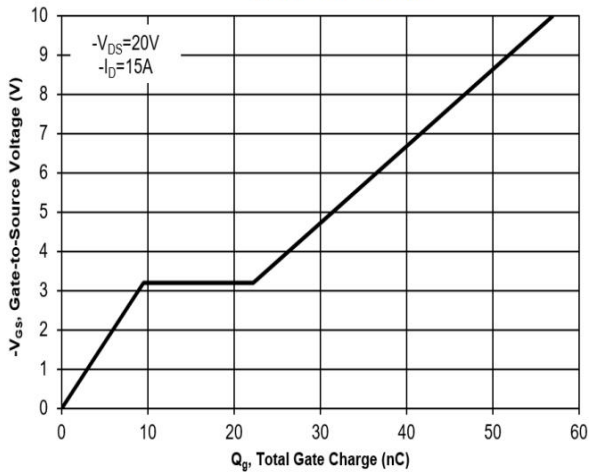
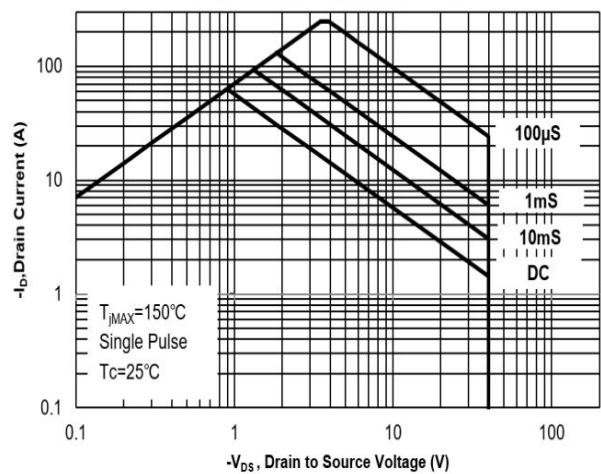

Fig. 12 Safe Operation Area



Typical Characteristics

Fig. 13 Normalized Maximum Transient Thermal Impedance($Z_{\theta JC}$)

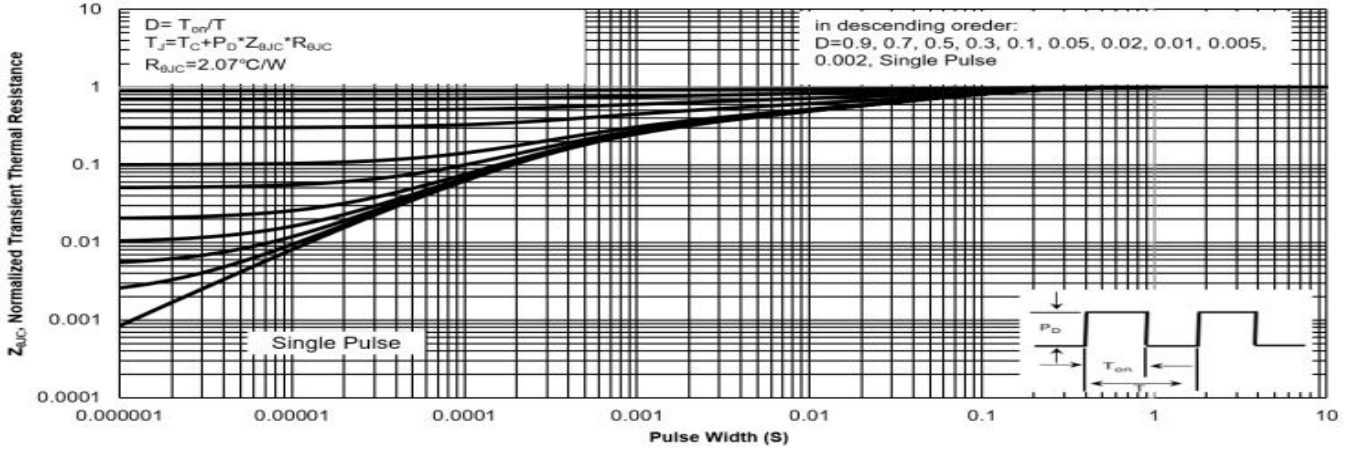
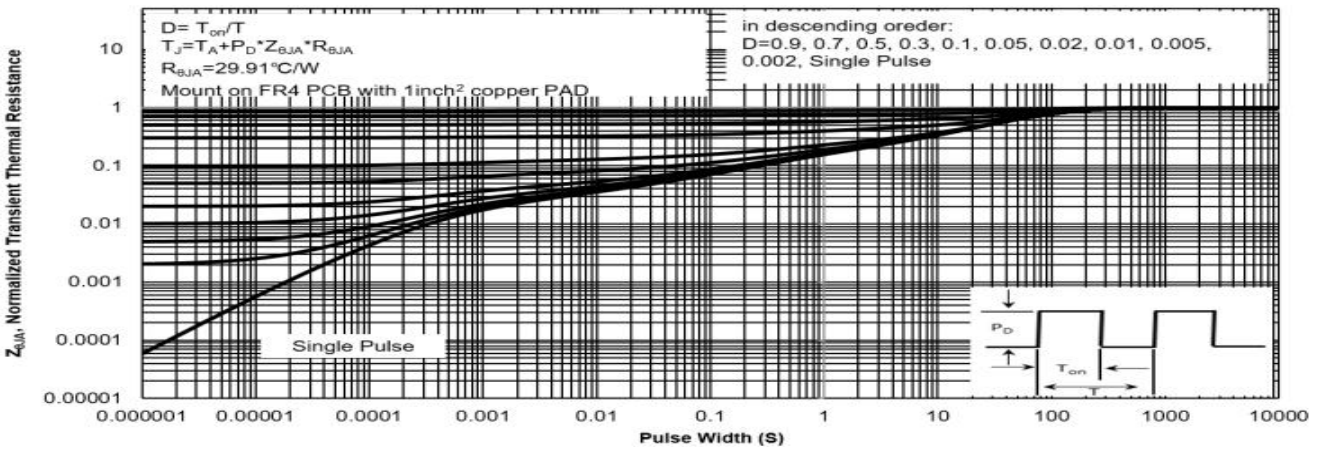
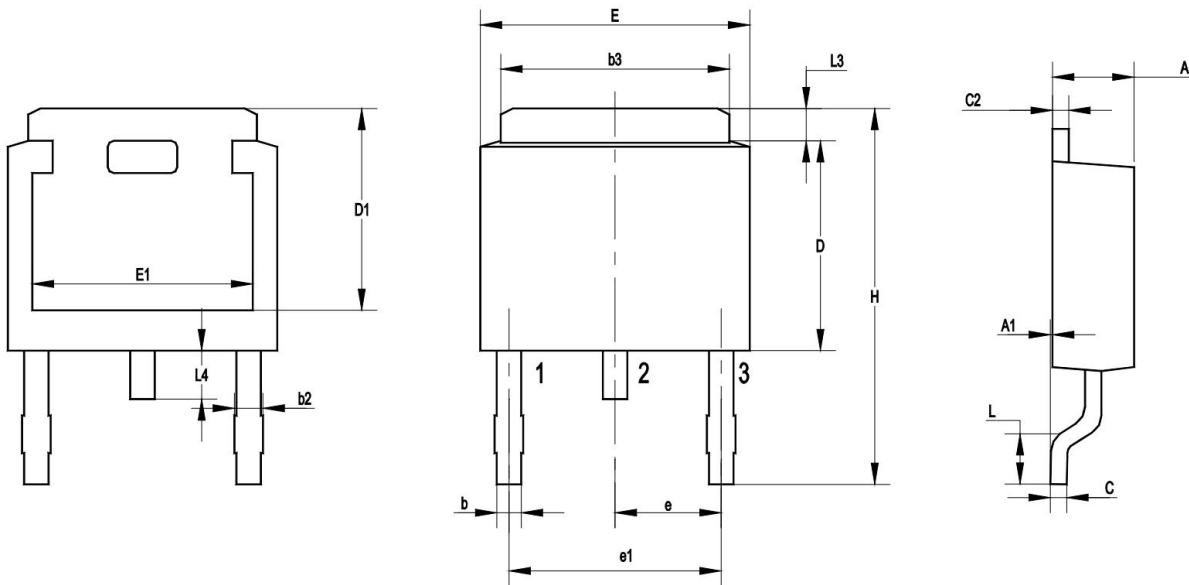

Fig. 14 Normalized Maximum Transient Thermal Impedance($Z_{\theta JA}$)



TO-252AB Package Information



Symbol	Dimensions In Millimeters		Dimensions In Inches	
	Min.	Max.	Min.	Max.
A	2.100	2.500	0.083	0.098
A1	0.000	0.150	0.000	0.006
b	0.500	1.000	0.020	0.039
b2	0.650	1.150	0.026	0.045
b3	4.900	5.500	0.193	0.217
C	0.400	0.650	0.016	0.026
C2	0.400	0.650	0.016	0.026
D	5.600	6.200	0.220	0.244
D1	5.000	5.400	0.197	0.213
E	6.100	6.700	0.240	0.264
E1	4.600	5.000	0.181	0.197
e	2.300 TYP.		0.091 TYP.	
e1	4.600 TYP.		0.181 TYP.	
H	9.000	10.700	0.354	0.421
L	1.400	1.780	0.055	0.070
L3	0.850	1.200	0.033	0.047
L4	0.510	1.100	0.020	0.043