

### Product Summary

$V_{(BR)DSS}$	$R_{DS(on)MAX}$	$I_D$
85V	3.8mΩ@10V	160A

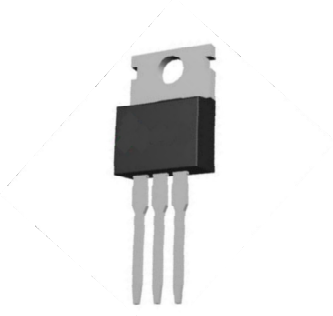
### Feature

- High density cell design for ultra low Rdson
- Fully characterized avalanche voltage and current
- Good stability and uniformity with high  $E_{AS}$
- Excellent package for good heat dissipation

### Application

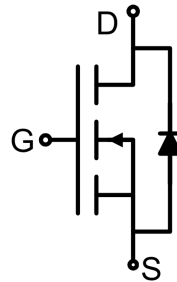
- DC/DC Converter
- Ideal for high-frequency switching and synchronous rectification

### Package

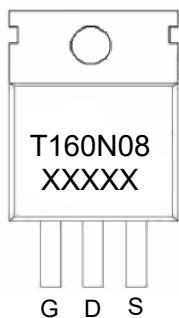


TO-220AB

### Circuit diagram



### Marking



### Absolute maximum ratings (Ta=25°C unless otherwise noted)

Parameter	Symbol	Value	Unit
Drain-Source Voltage	V <sub>DS</sub>	85	V
Gate-Source Voltage	V <sub>GS</sub>	±20	V
Continuous Drain Current	I <sub>D</sub>	160	A
Drain Current-Continuous(T <sub>C</sub> =100°C)	I <sub>D</sub> (100°C)	112	A
Pulsed Drain Current	I <sub>DM</sub>	480	A
Power Dissipation	P <sub>D</sub>	220	W
Thermal Resistance,Junction-to-Case	R <sub>θJC</sub>	0.6	°C/W
Single pulse avalanche energy	E <sub>AS</sub>	1440	mJ
Junction Temperature	T <sub>J</sub>	150	°C
Storage Temperature	T <sub>STG</sub>	-55 ~ +150	°C

### Electrical characteristics (T<sub>A</sub>=25 °C, unless otherwise noted)

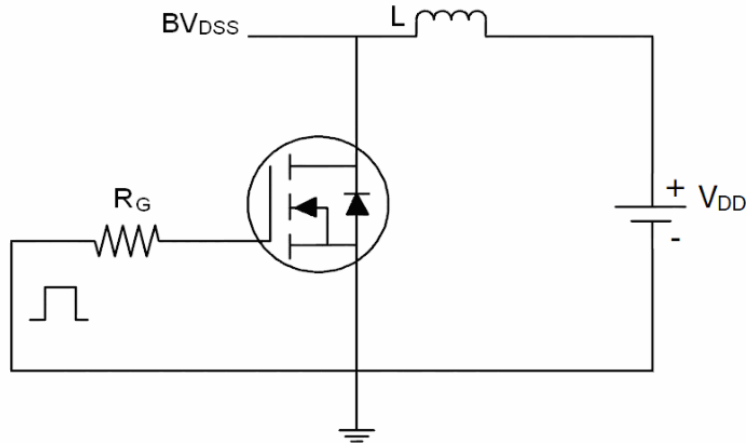
Parameter	Symbol	Test Condition	Min.	Typ.	Max.	Unit
<b>Static Characteristics</b>						
Drain-source breakdown voltage	V <sub>(BR)DSS</sub>	V <sub>GS</sub> = 0V, I <sub>D</sub> =250μA	85			V
Zero gate voltage drain current	I <sub>DSS</sub>	V <sub>DS</sub> =85V, V <sub>GS</sub> = 0V			1	μA
Gate-body leakage current	I <sub>GSS</sub>	V <sub>GS</sub> =±20V, V <sub>DS</sub> = 0V			±100	nA
Gate threshold voltage	V <sub>GS(th)</sub>	V <sub>DS</sub> =V <sub>GS</sub> , I <sub>D</sub> =250μA	2.5		4.5	V
Drain-source on-resistance <sup>1)</sup>	R <sub>DS(on)</sub>	V <sub>GS</sub> =10V, I <sub>D</sub> =80A		3.1	3.8	mΩ
Forward transconductance <sup>1)</sup>	g <sub>FS</sub>	V <sub>DS</sub> =10V, I <sub>D</sub> =80A	75			S
<b>Dynamic characteristics<sup>2)</sup></b>						
Input Capacitance	C <sub>iss</sub>	V <sub>DS</sub> =40V, V <sub>GS</sub> =0V, f =1MHz		8500		pF
Output Capacitance	C <sub>oss</sub>			1520		
Reverse Transfer Capacitance	C <sub>rss</sub>			81		
Total Gate Charge	Q <sub>g</sub>	V <sub>DS</sub> =40V, V <sub>GS</sub> =10V, I <sub>D</sub> =80A		105		nC
Gate-Source Charge	Q <sub>gs</sub>			39		
Gate-Drain Charge	Q <sub>gd</sub>			28		
Turn-on delay time	t <sub>d(on)</sub>	V <sub>DD</sub> =40V, V <sub>GS</sub> =10V, I <sub>D</sub> =80A, R <sub>GEN</sub> =4.7Ω		30.5		nS
Turn-on rise time	t <sub>r</sub>			29		
Turn-off delay time	t <sub>d(off)</sub>			95		
Turn-off fall time	t <sub>f</sub>			34.5		
<b>Source-Drain Diode characteristics</b>						
Diode Forward Current <sup>1)</sup>	I <sub>S</sub>				160	A
Diode Forward voltage	V <sub>DS</sub>	V <sub>GS</sub> =0V, I <sub>S</sub> =80A			1.2	V
Reverse Recovery Time	t <sub>rr</sub>	T <sub>J</sub> = 25°C, I <sub>F</sub> = I <sub>S</sub> di/dt = 100A/μs <sup>1)</sup>		95		nS
Reverse Recovery Charge	Q <sub>rr</sub>			225		nC

Notes:

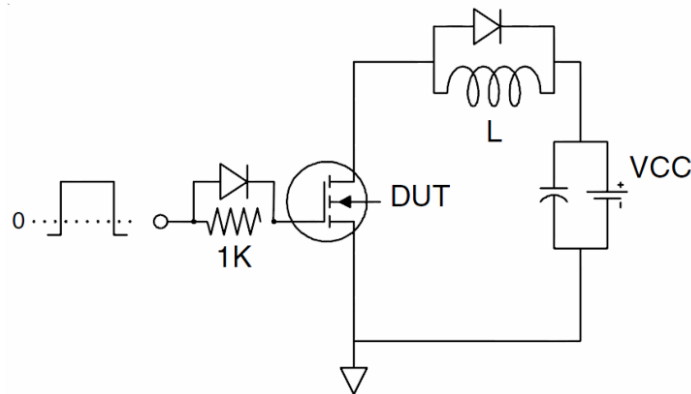
- 1) Pulse Test: Pulse Width < 300μs, Duty Cycle ≤2%.
- 2) Guaranteed by design, not subject to production testing.

## Test Circuit

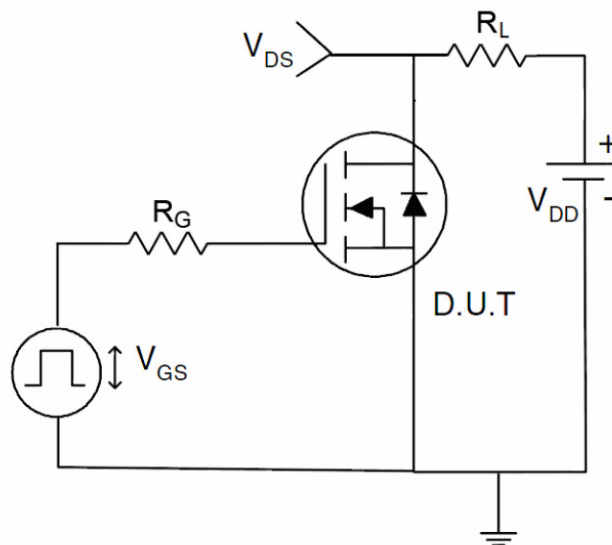
### 1) E<sub>AS</sub> test Circuit



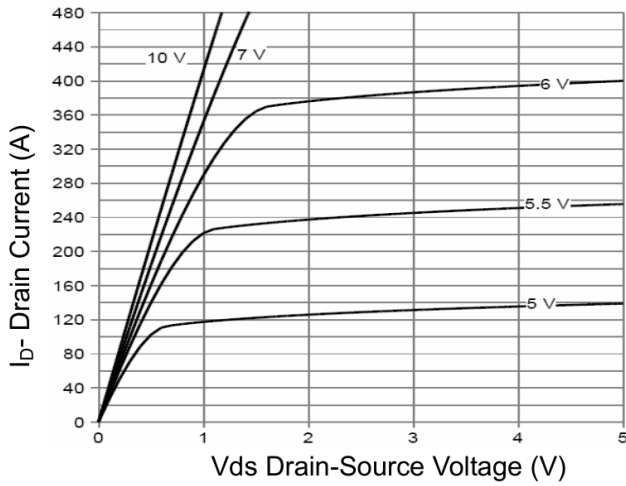
### 2) Gate charge test Circuit



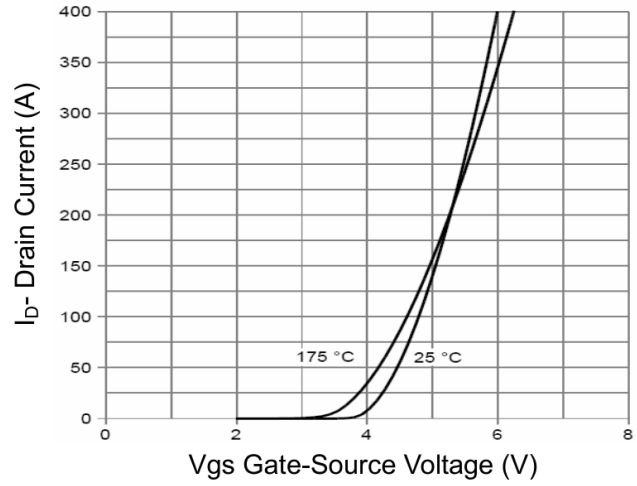
### 3) Switch Time Test Circuit



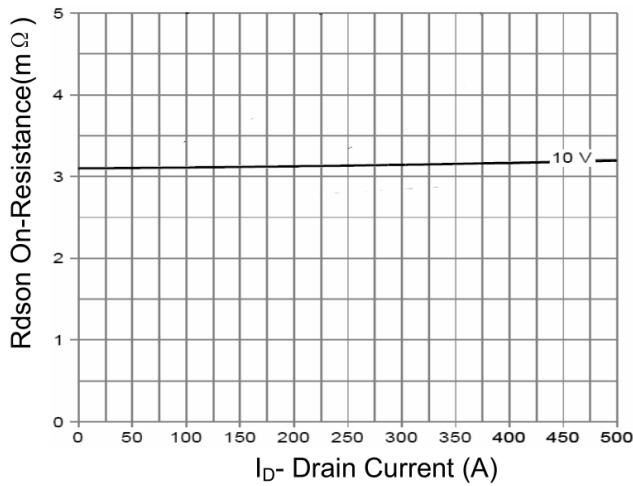
## Typical Characteristics



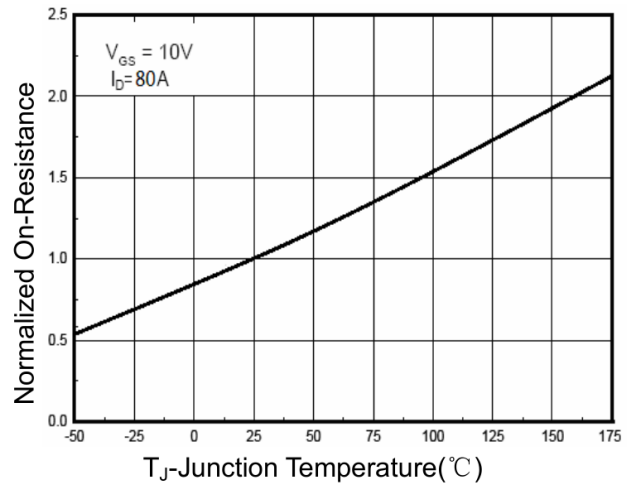
**Figure 1 Output Characteristics**



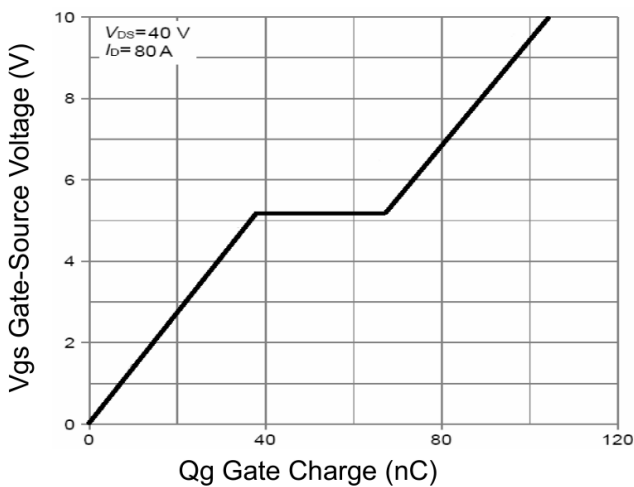
**Figure 2 Transfer Characteristics**



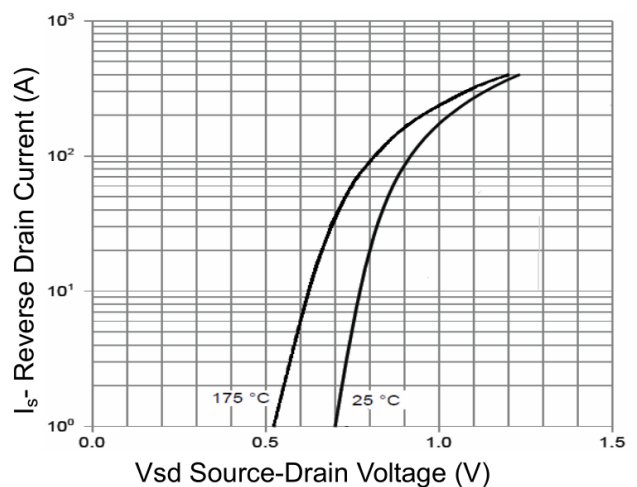
**Figure 3 Rdson- Drain Current**



**Figure 4 Rdson-Junction Temperature**

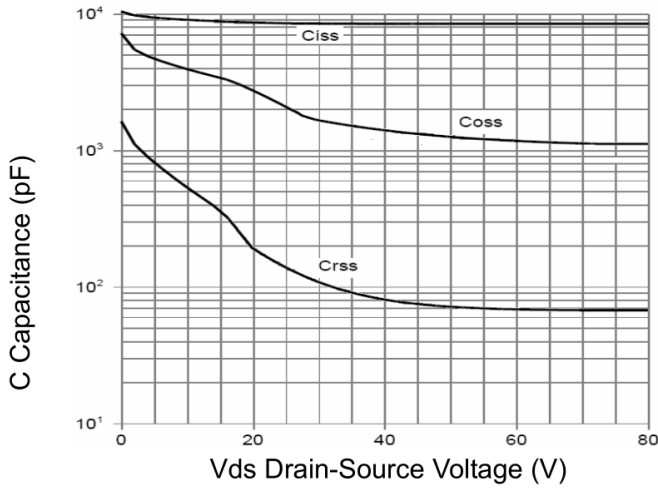


**Figure 5 Gate Charge**

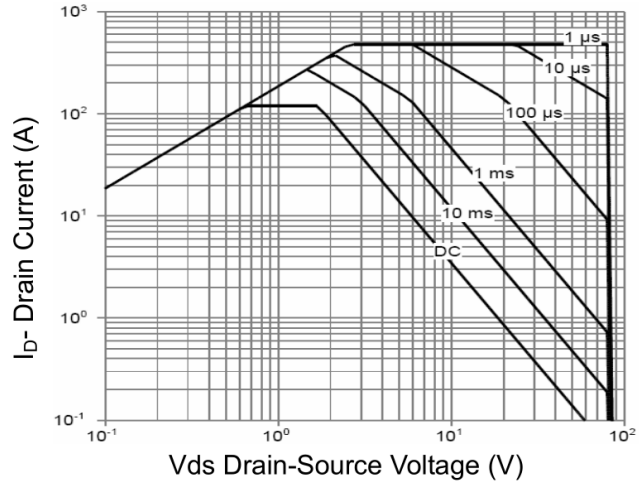


**Figure 6 Source- Drain Diode Forward**

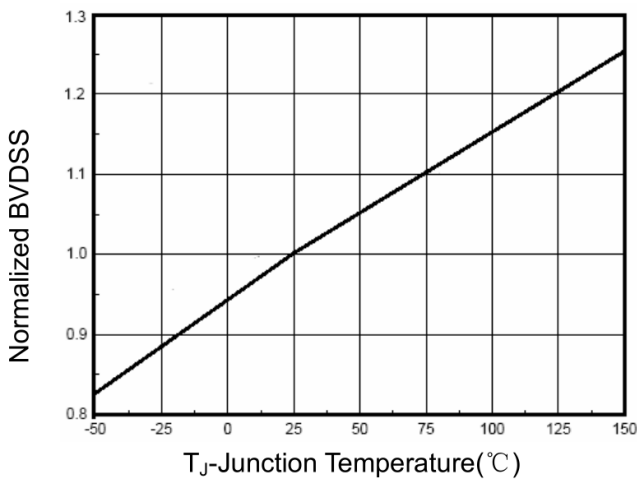
## Typical Characteristics



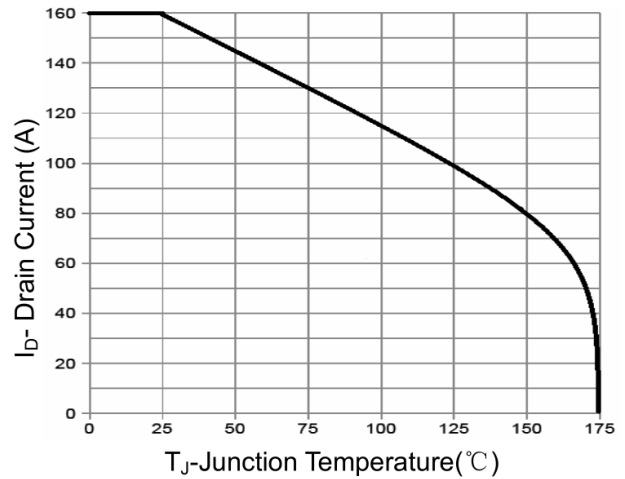
**Figure 7 Capacitance vs Vds**



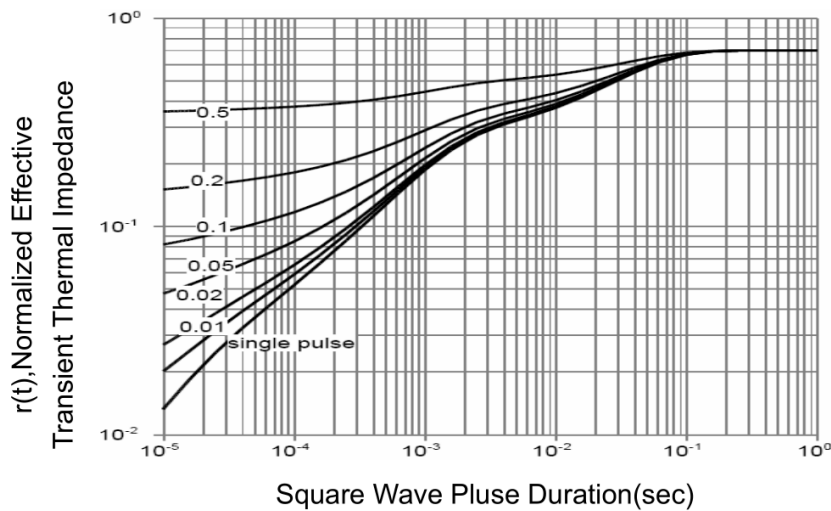
**Figure 8 Safe Operation Area**



**Figure 9 BV<sub>DSS</sub> vs Junction Temperature**

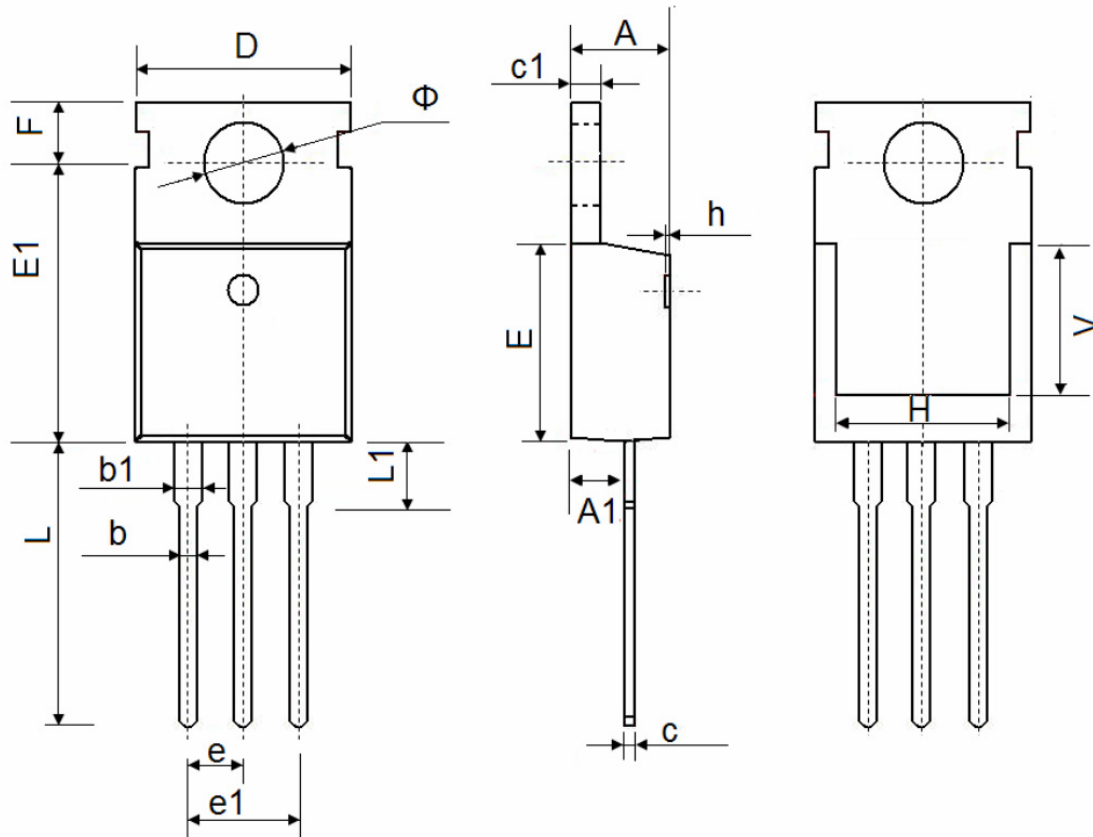


**Figure 10 Current De-rating**



**Figure 11 Normalized Maximum Transient Thermal Impedance**

### TO-220AB Package Information



Symbol	Dimensions In Millimeters		Dimensions In Inches	
	Min.	Max.	Min.	Max.
A	4.400	4.600	0.173	0.181
A1	2.250	2.550	0.089	0.100
b	0.710	0.910	0.028	0.036
b1	1.170	1.370	0.046	0.054
c	0.330	0.650	0.013	0.026
c1	1.200	1.400	0.047	0.055
D	9.910	10.250	0.390	0.404
E	8.9500	9.750	0.352	0.384
E1	12.650	12.950	0.498	0.510
e	2.540 TYP.		0.100 TYP.	
e1	4.980	5.180	0.196	0.204
F	2.650	2.950	0.104	0.116
H	7.900	8.100	0.311	0.319
h	0.000	0.300	0.000	0.012
L	12.900	13.400	0.508	0.528
L1	2.850	3.250	0.112	0.128
V	7.500 REF.		0.295 REF.	
Φ	3.400	3.800	0.134	0.150