

Product Summary

$V_{(BR)DSS}$	$R_{DS(on)MAX}$	I_D
30V	47mΩ@10V	10A
	78mΩ@4.5V	

Feature

- Trench Power LV MOSFET technology
- High density cell design for low $R_{DS(ON)}$
- Excellent package for heat dissipation
- Suffix "-Q1" for AEC-Q101

Application

- Power switching application
- Uninterruptible power supply
- DC-DC convertor

Package

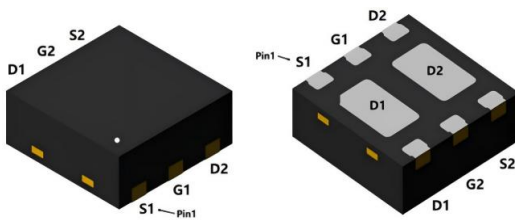

DFN2*2-6L

Circuit diagram

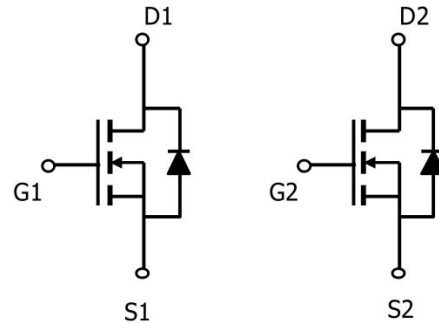

Marking

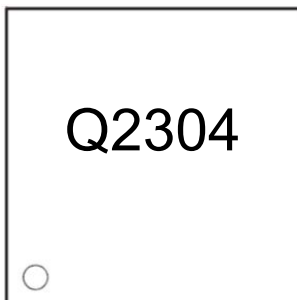

Absolute maximum ratings ($T_A=25^\circ\text{C}$ unless otherwise noted)

Parameter	Symbol	Value	Unit
Drain-Source Voltage	V_{DS}	30	V
Gate-Source Voltage	V_{GS}	± 20	V
Continuous Drain Current ($T_C=25^\circ\text{C}$)	I_D	10	A
Continuous Drain Current ($T_C=100^\circ\text{C}$)	$I_D(100^\circ\text{C})$	6	A
Pulsed Drain Current ¹⁾	I_{DM}	30	A
Power Dissipation ²⁾ ($T_C=25^\circ\text{C}$)	P_D	8.9	W
Thermal Resistance Junction to Case	$R_{\theta JC}$	14	$^\circ\text{C}/\text{W}$
Operating Junction Temperature	T_J	-55 ~ +150	$^\circ\text{C}$
Storage Temperature	T_{STG}	-55 ~ +150	$^\circ\text{C}$

Electrical characteristics ($T_J=25^\circ\text{C}$ unless otherwise noted)

Parameter	Symbol	Test Condition	Min.	Typ.	Max.	Unit
Static Characteristics						
Drain-source breakdown voltage	$V_{(BR)DSS}$	$V_{GS}=0\text{V}, I_D=250\mu\text{A}$	30			V
Zero gate voltage drain current	I_{DSS}	$V_{DS}=30\text{V}, V_{GS}=0\text{V}$			1	μA
Gate-body leakage current	I_{GSS}	$V_{DS}=0\text{V}, V_{GS}=\pm 20\text{V}$			± 100	nA
Gate threshold voltage	$V_{GS(th)}$	$V_{DS}=V_{GS}, I_D=250\mu\text{A}$	1	1.5	2.5	V
Drain-source on-resistance	$R_{DS(on)}$	$V_{GS}=10\text{V}, I_D=5\text{A}$		37	47	m Ω
		$V_{GS}=4.5\text{V}, I_D=4\text{A}$		56	78	
Dynamic characteristics³⁾						
Input Capacitance	C_{iss}	$V_{DS}=15\text{V}, V_{GS}=0\text{V}, f=1\text{MHz}$		155		pF
Output Capacitance	C_{oss}			35		
Reverse Transfer Capacitance	C_{rss}			25		
Total Gate Charge	Q_g	$V_{DS}=15\text{V}, V_{GS}=10\text{V}, I_D=3.5\text{A}$		4.4		nC
Gate-Source Charge	Q_{gs}			1.1		
Gate-Drain Charge	Q_{gd}			0.85		
Turn-on delay time	$t_{d(on)}$	$V_{DS}=15\text{V}, V_{GS}=10\text{V}, I_D=3.5\text{A}$ $R_G=3\Omega$		1.1		nS
Turn-on rise time	t_r			36		
Turn-off delay time	$t_{d(off)}$			9.5		
Turn-off fall time	t_f			7.5		
Source-Drain Diode characteristics						
Diode Forward Current	I_S				10	A
Diode Forward voltage	V_{SD}	$V_{GS}=0\text{V}, I_S=4\text{A}$			1.2	V
Reverse Recovery Time	T_{rr}	$I_F=3.5\text{A}, di/dt=-60\text{A}/\mu\text{s}$		9.5		nS
Reverse Recovery Charge	Q_{rr}			0.7		nC

Notes:

- 1) Repetitive Rating: Pulse Width Limited by Maximum Junction Temperature.
- 2) P_D is based on max. junction temperature, using junction-case thermal resistance.
- 3) Guaranteed by design, not subject to production.

Typical Characteristics

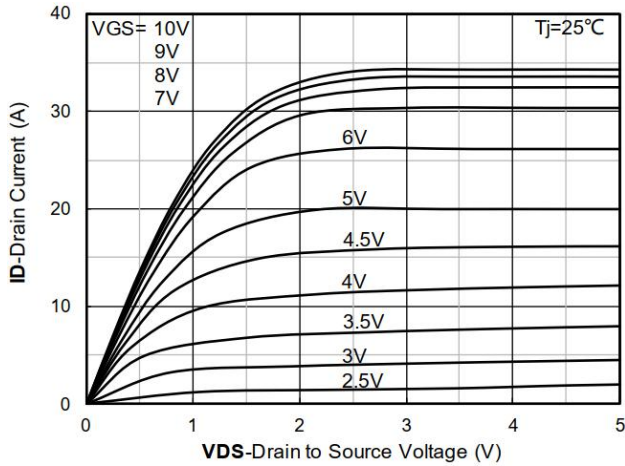

Figure 1. Output Characteristics

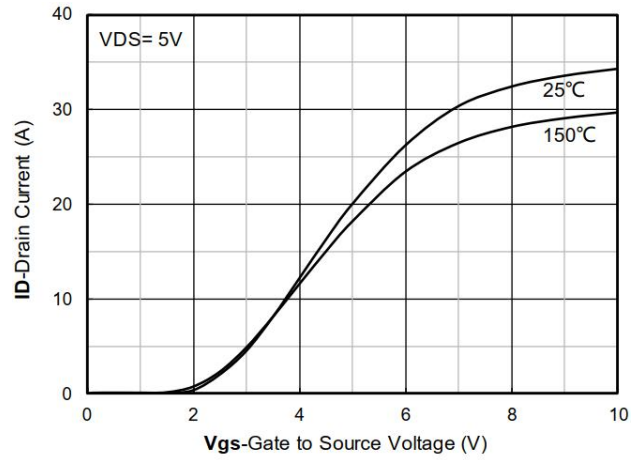

Figure 2. Transfer Characteristics

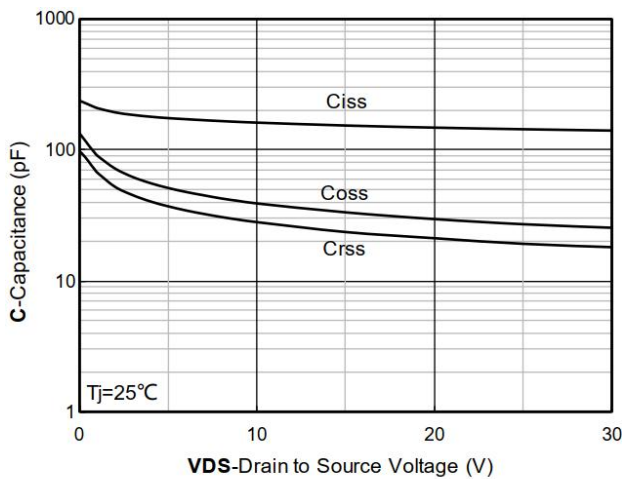

Figure 3. Capacitance Characteristics

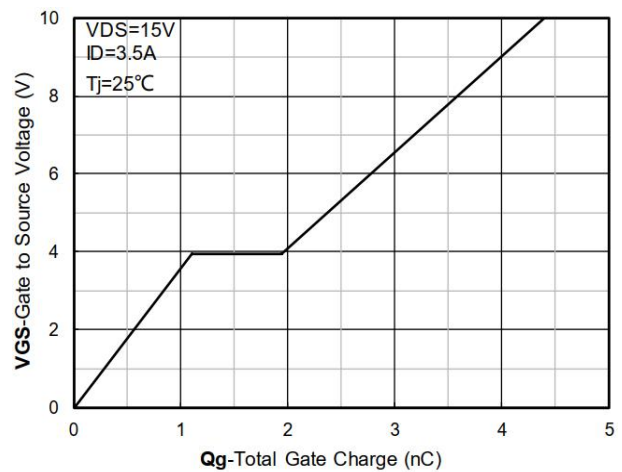

Figure 4. Gate Charge

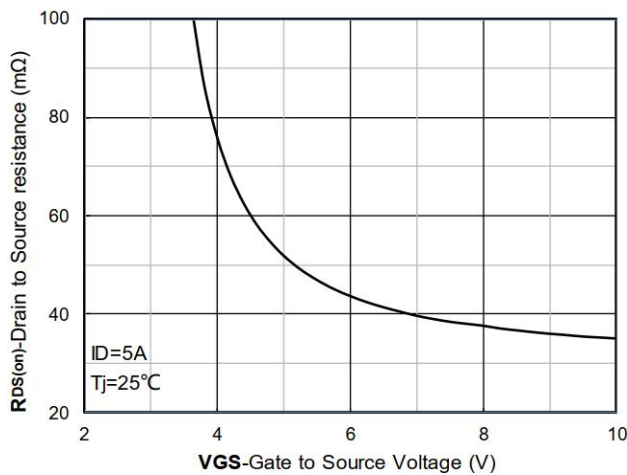

Figure 5. On-Resistance vs Gate to Source Voltage

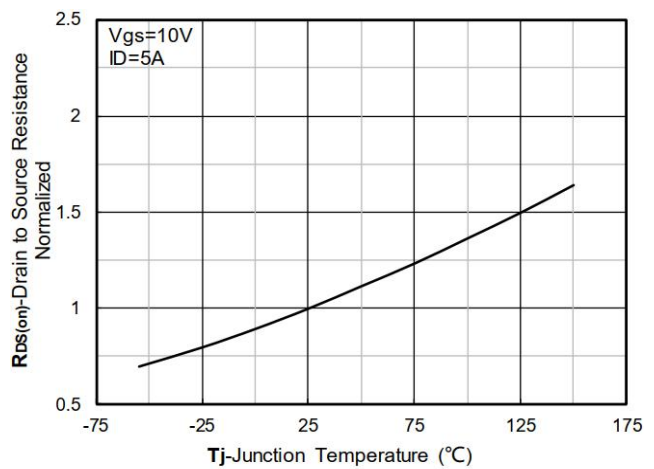

Figure 6. Normalized On-Resistance

Typical Characteristics

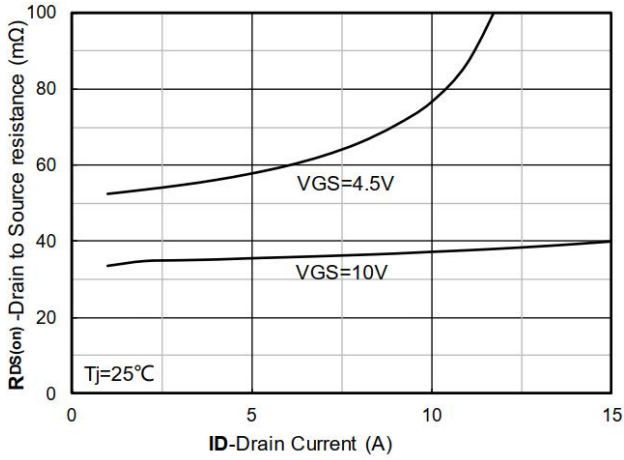

Figure 7. $R_{DS(on)}$ VS Drain Current

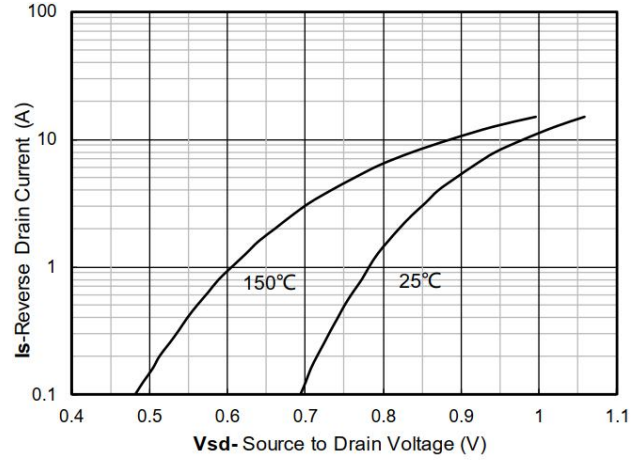

Figure 8. Forward characteristics of reverse diode

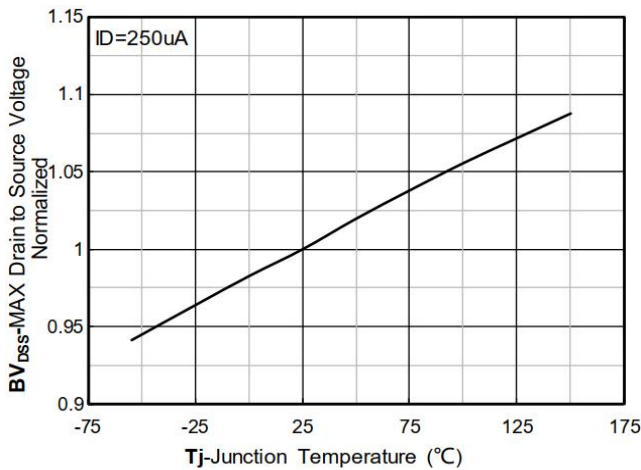

Figure 9. Normalized breakdown voltage

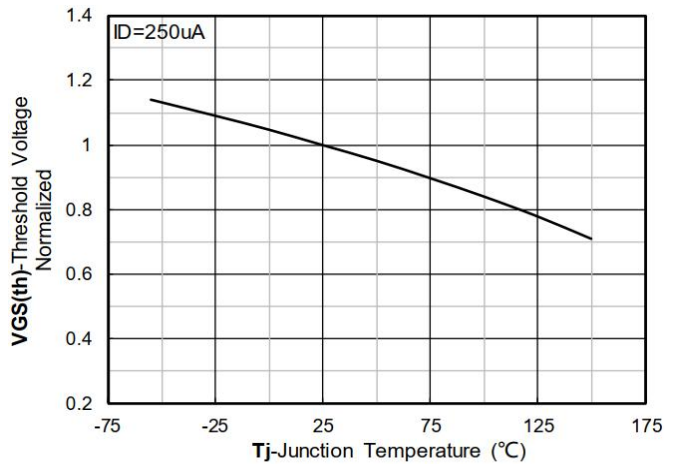

Figure 10. Normalized Threshold voltage

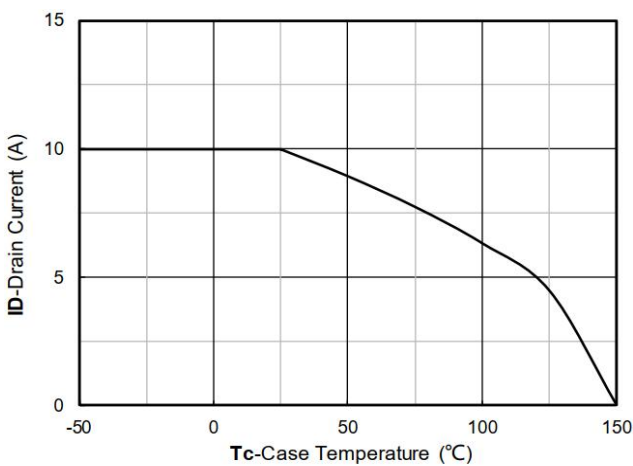

Figure 11. Current dissipation

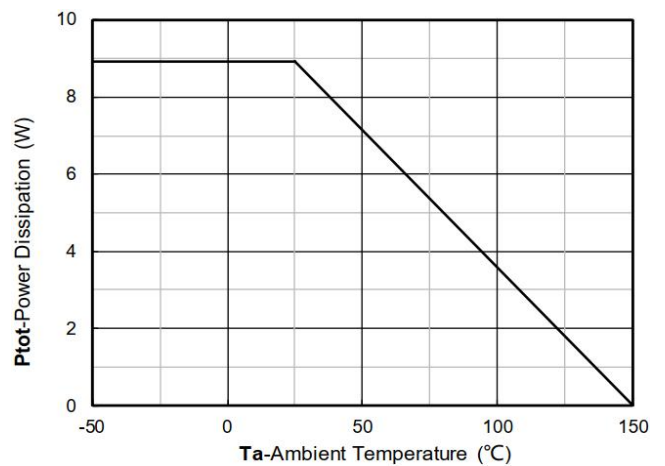

Figure 12. Power dissipation

Typical Characteristics

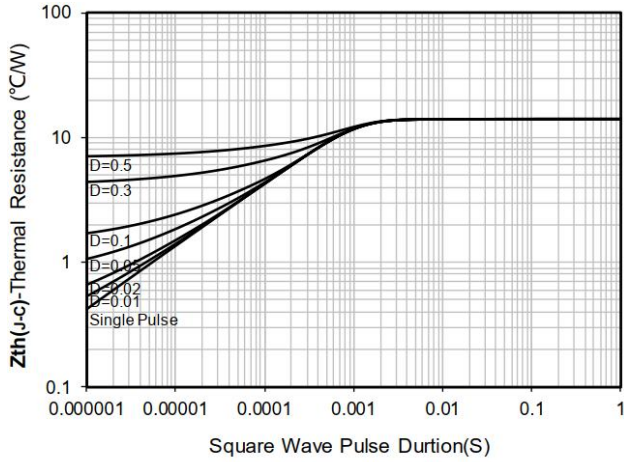

Figure 13. Maximum Transient Thermal Impedance

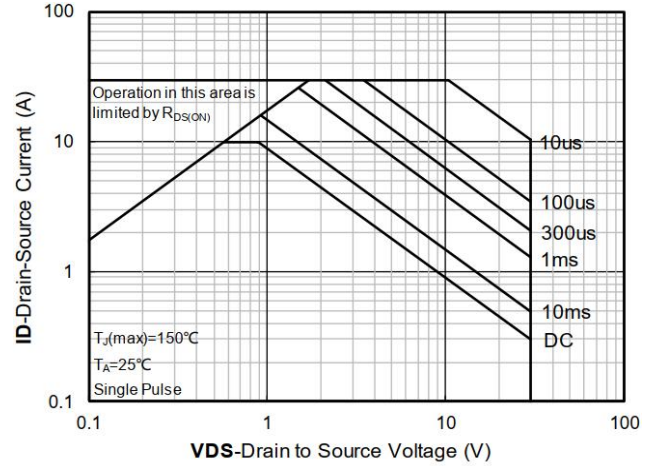
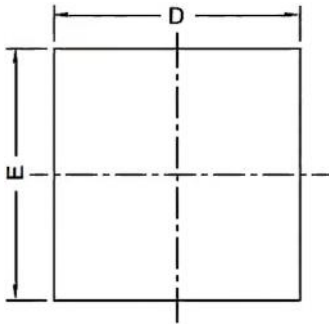
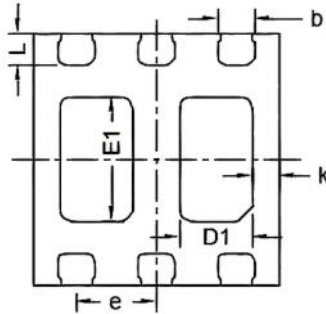

Figure 14. Safe Operation Area

DFN2*2-6L Package Information



Top View



Bottom View

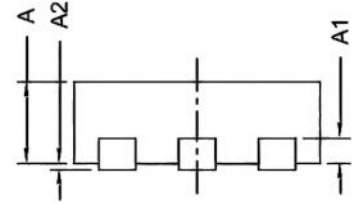

Side View

Symbol	Dimensions In Millimeters		Dimensions In Inches	
	Min.	Max.	Min.	Max.
D	1.900	2.100	0.075	0.083
E	1.900	2.100	0.075	0.083
A	0.550	0.750	0.022	0.030
A1	0.200 BSC.		0.008 BSC.	
A2	-	0.100	-	0.004
D1	0.490	0.690	0.019	0.027
E1	0.890	1.090	0.035	0.043
L	0.150	0.350	0.006	0.014
b	0.200	0.400	0.008	0.016
e	0.650 BSC.		0.026 BSC.	
k	0.215 BSC.		0.008 BSC.	