

Product Summary

$V_{(BR)DSS}$	$R_{DS(on)MAX}$	I_b
30V	20mΩ@10V	6.5A
	41mΩ@4.5V	

Feature

- Trench power LV MOSFET technology
- High density cell design for low $R_{DS(ON)}$
- High speed switching
- Suffix "-Q1" for AEC-Q101

Application

- Battery protection
- Load switch
- Power management

Package



SOP-8

Circuit diagram

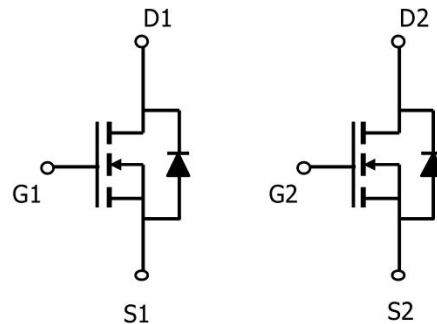

Marking



Absolute maximum ratings ($T_A=25^{\circ}\text{C}$ unless otherwise noted)

Parameter	Symbol	Value	Unit
Drain-Source Voltage	V_{DS}	30	V
Gate-Source Voltage	V_{GS}	± 20	V
Continuous Drain Current	I_D	6.5	A
Continuous Drain Current ($T_A=100^{\circ}\text{C}$)	$I_{D(100^{\circ}\text{C})}$	4.1	A
Pulsed Drain Current ¹⁾	I_{DM}	50	A
Power Dissipation ²⁾	P_D	1.25	W
Thermal Resistance Junction to Ambient ³⁾	$R_{\theta JA}$	100	$^{\circ}\text{C}/\text{W}$
Operating Junction Temperature	T_J	-55 ~ +150	$^{\circ}\text{C}$
Storage Temperature	T_{STG}	-55 ~ +150	$^{\circ}\text{C}$

Electrical characteristics ($T_J=25^{\circ}\text{C}$, unless otherwise noted)

Parameter	Symbol	Test Condition	Min.	Typ.	Max.	Unit
Static Characteristics						
Drain-source breakdown voltage	$V_{(BR)DSS}$	$V_{GS} = 0\text{V}, I_D = 250\mu\text{A}$	30			V
Zero gate voltage drain current	I_{DSS}	$V_{DS} = 30\text{V}, V_{GS} = 0\text{V}$			1	μA
Gate-body leakage current	I_{GSS}	$V_{DS} = 0\text{V}, V_{GS} = \pm 20\text{V}$			± 100	nA
Gate threshold voltage	$V_{GS(th)}$	$V_{DS} = V_{GS}, I_D = 250\mu\text{A}$	1	1.5	2.2	V
Drain-source on-resistance	$R_{DS(on)}$	$V_{GS} = 10\text{V}, I_D = 6.5\text{A}$		15.5	20	m Ω
		$V_{GS} = 4.5\text{V}, I_D = 6\text{A}$		30	41	
Dynamic characteristics⁴⁾						
Input Capacitance	C_{iss}	$V_{DS} = 15\text{V}, V_{GS} = 0\text{V}, f = 1\text{MHz}$		390		pF
Output Capacitance	C_{oss}			70		
Reverse Transfer Capacitance	C_{rss}			55		
Total Gate Charge	Q_g	$V_{DS} = 15\text{V}, V_{GS} = 10\text{V}, I_D = 5.6\text{A}$		8.3		nC
Gate-Source Charge	Q_{gs}			1.5		
Gate-Drain Charge	Q_{gd}			2.5		
Turn-on delay time	$t_{d(on)}$	$V_{DS} = 15\text{V}, V_{GS} = 10\text{V}, I_D = 5.6\text{A}$ $R_G = 2.2\Omega$		5		nS
Turn-on rise time	t_r			31		
Turn-off delay time	$t_{d(off)}$			13		
Turn-off fall time	t_f			3		
Source-Drain Diode characteristics						
Diode Forward Current	I_S				6.5	A
Diode Forward voltage	V_{SD}	$V_{GS} = 0\text{V}, I_S = 6.5\text{A}$			1.2	V
Reverse recover time	T_{rr}	$I_F = 5.6\text{A}, di/dt = -175\text{A}/\mu\text{s}$		9		nS
Reverse recovery charge	Q_{rr}			6		nC

Notes:

- 1) Repetitive rating; pulse width limited by max. junction temperature.
- 2) P_D is based on max. junction temperature, using junction-case thermal resistance.
- 3) The value of $R_{\theta JA}$ is measured with the device mounted on the minimum recommend pad size, in the still air environment with $T_A = 25^{\circ}\text{C}$. The maximum allowed junction temperature of 150°C .
The value in any given application depends on the user's specific board design.
- 4) Guaranteed by design, not subject to production testing.

Typical Characteristics

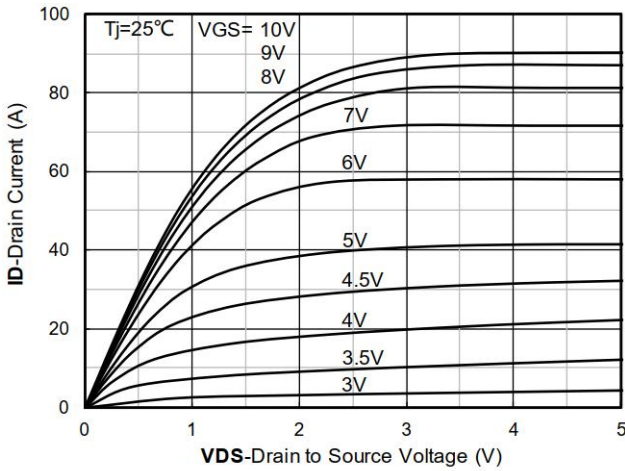

Figure 1. Output Characteristics

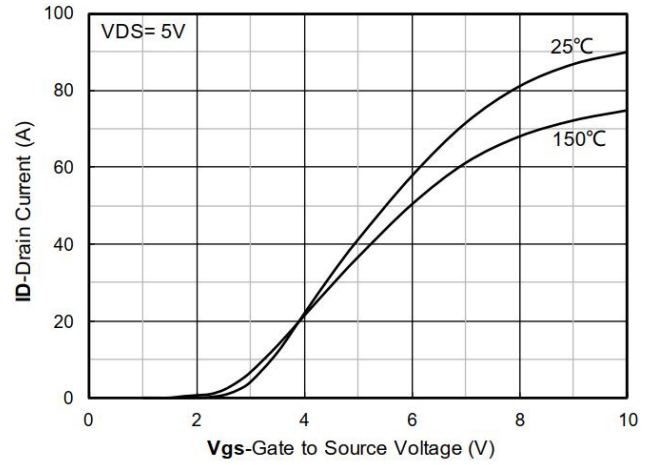

Figure 2. Transfer Characteristics

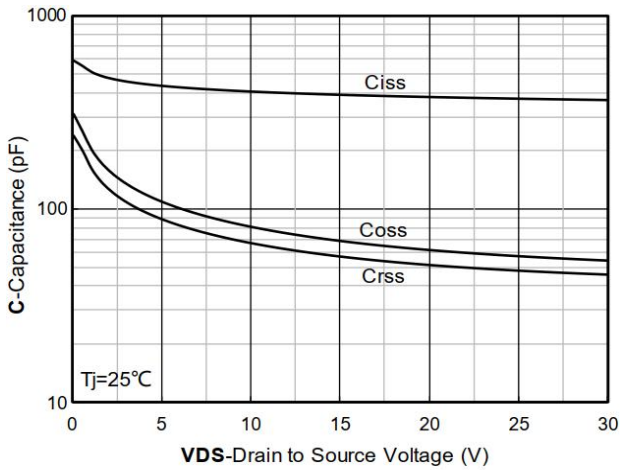

Figure 3. Capacitance Characteristics

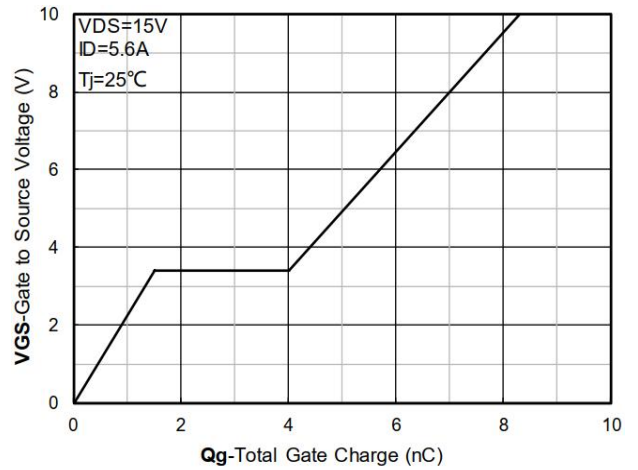

Figure 4. Gate Charge

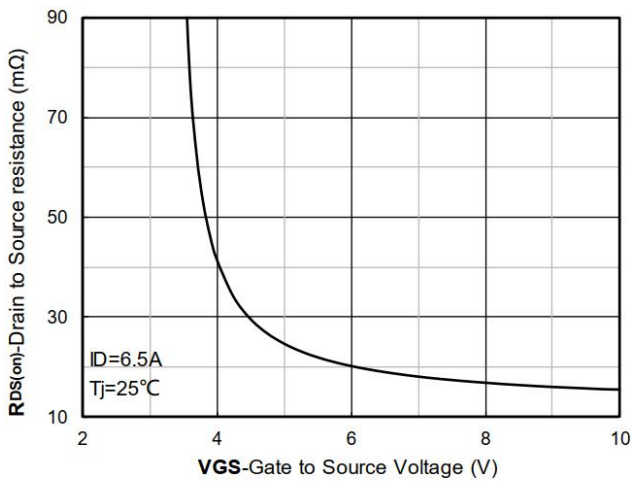

Figure 5. On-Resistance vs Gate to Source Voltage

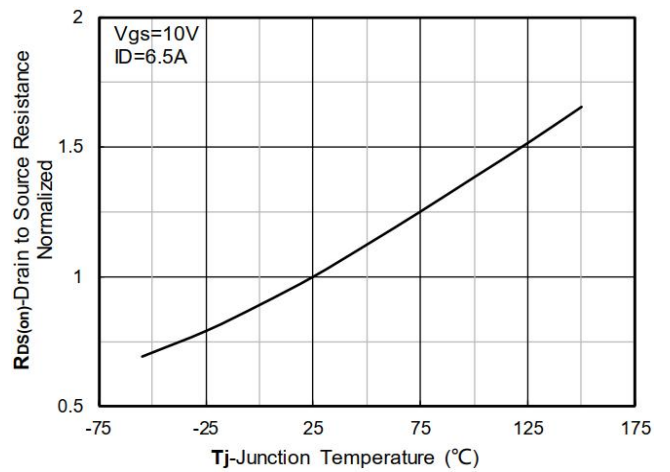

Figure 6. Normalized On-Resistance

Typical Characteristics

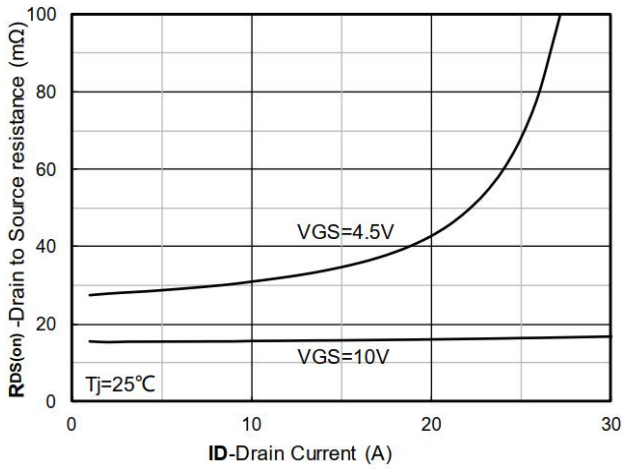

Figure 7. $R_{DS(on)}$ VS Drain Current

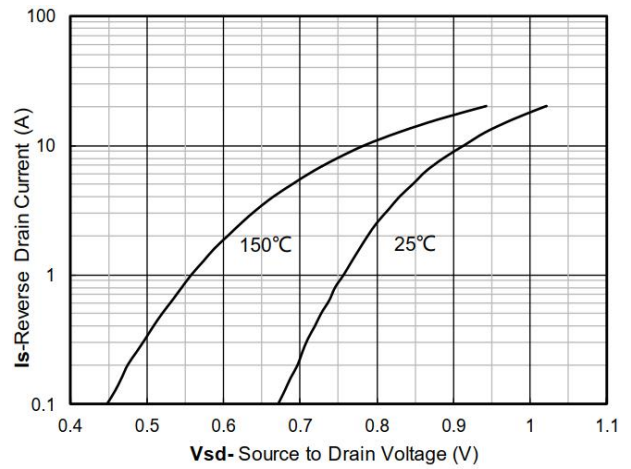

Figure 8. Forward characteristics of reverse diode

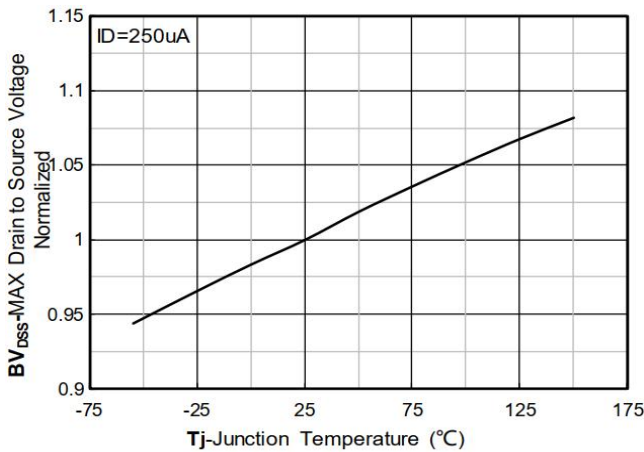

Figure 9. Normalized breakdown voltage

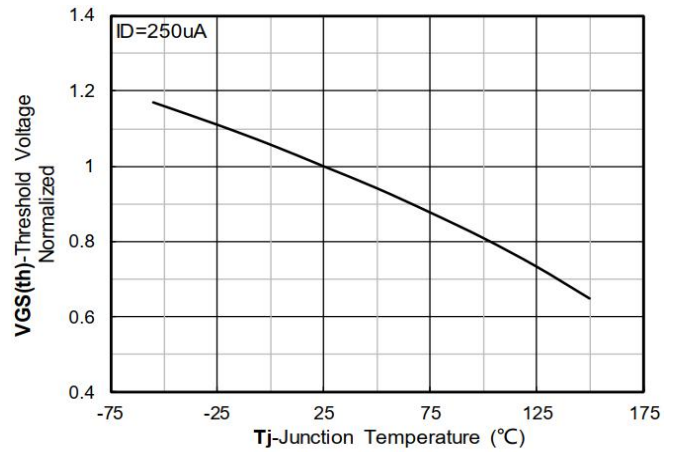

Figure 10. Normalized Threshold voltage

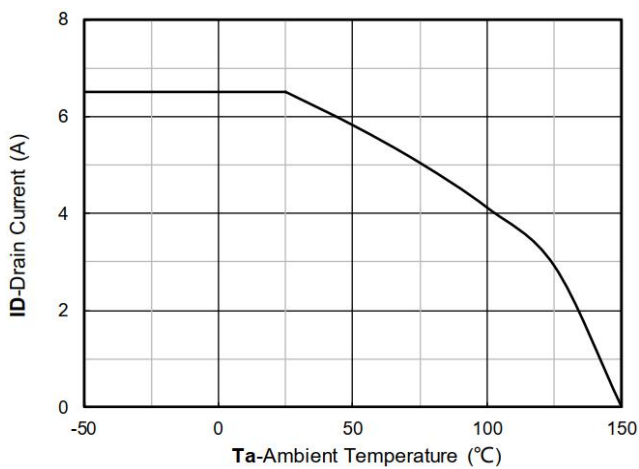

Figure 11. Current dissipation

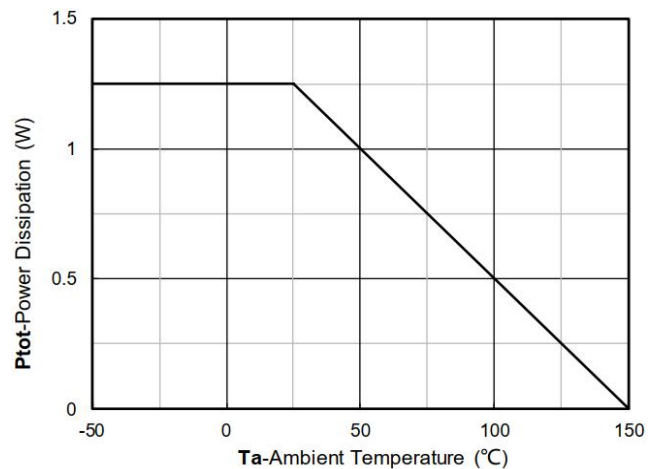

Figure 12. Power dissipation

Typical Characteristics

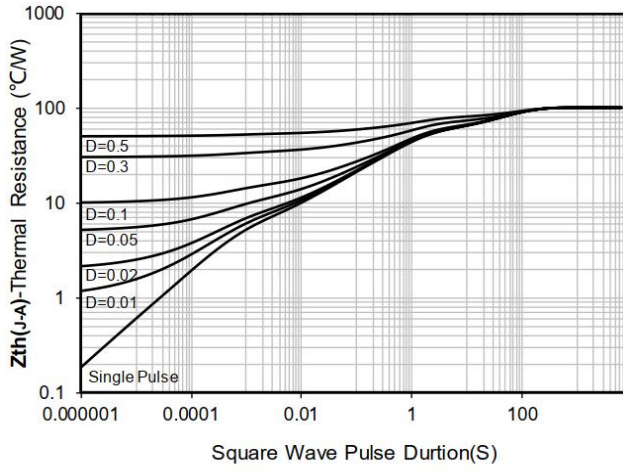

Figure 13. Maximum Transient Thermal Impedance

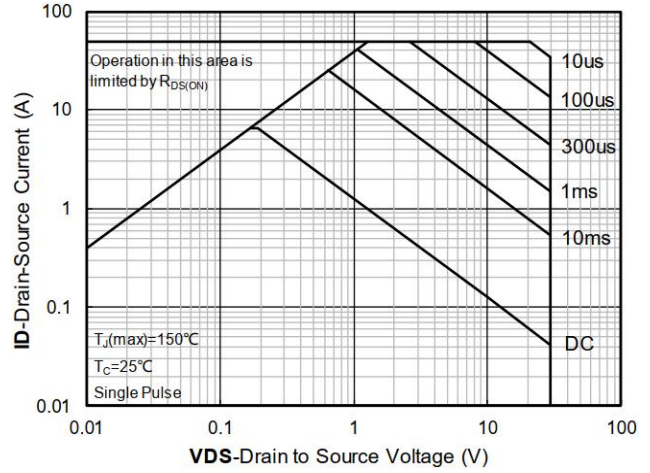
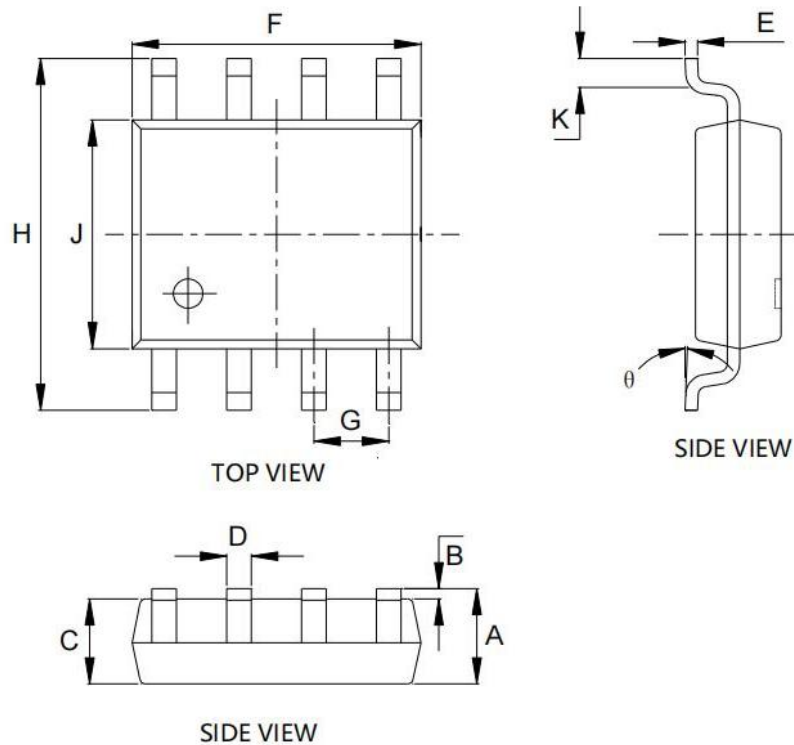

Figure 14. Safe Operation Area

SOP-8 Package Information



Symbol	Dimensions In Millimeters		Dimensions In Inches	
	Min.	Max.	Min.	Max.
A	1.350	1.750	0.053	0.069
B	0.100	0.250	0.004	0.010
C	1.350	1.550	0.053	0.061
D	0.330	0.510	0.013	0.020
E	0.170	0.250	0.007	0.010
F	4.800	5.000	0.189	0.197
G	1.270 BSC.		0.050 BSC.	
H	5.800	6.200	0.228	0.244
J	3.800	4.000	0.150	0.157
K	0.400	1.270	0.016	0.050
θ	0°	8°	0°	8°