

Product Summary

$V_{(BR)DSS}$	$R_{DS(on)MAX}$	I_D
100V	8.5mΩ@10V	78A
	12.0mΩ@4.5V	

Feature

- Excellent gate charge x $R_{DS(on)}$ product(FOM)
- Very low on-resistance $R_{DS(on)}$
- Pb-free lead plating
- Suffix "-Q1" for AEC-Q101

Application

- DC/DC Converter
- Ideal for high-frequency switching and synchronous rectification

Package

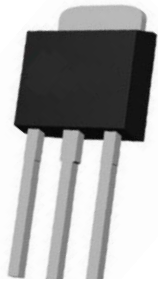

TO-251AB

Circuit diagram

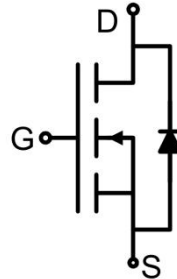

Marking



Absolute maximum ratings (Ta=25°C unless otherwise noted)

Parameter	Symbol	Value	Unit
Drain-Source Voltage	V _{DS}	100	V
Gate-Source Voltage	V _{GS}	±20	V
Continuous Drain Current	I _D	78	A
Drain Current-Continuous(T _C =100 °C)	I _D (100 °C)	60	A
Pulsed Drain Current	I _{DM}	320	A
Power Dissipation	P _D	125	W
Thermal Resistance,Junction-to-Case	R _{θJC}	1.2	°C/W
Single pulse avalanche energy	E _{AS}	320	mJ
Junction Temperature	T _J	150	°C
Storage Temperature	T _{STG}	-55 ~ +150	°C

Electrical characteristics (T_A=25 °C, unless otherwise noted)

Parameter	Symbol	Test Condition	Min.	Typ.	Max.	Unit
Static Characteristics						
Drain-source breakdown voltage	V _{(BR)DSS}	V _{GS} = 0V, I _D =250μA	100			V
Zero gate voltage drain current	I _{DSS}	V _{DS} =100V,V _{GS} = 0V			1	μA
Gate-body leakage current	I _{GSS}	V _{GS} =±20V, V _{DS} = 0V			±100	nA
Gate threshold voltage	V _{GS(th)}	V _{DS} =V _{GS} , I _D =250μA	1.2		2.2	V
Drain-source on-resistance ¹⁾	R _{DS(on)}	V _{GS} =10V, I _D =39A		7.2	8.5	mΩ
		V _{GS} =4.5V, I _D =39A		9.5	12.0	
Dynamic characteristics²⁾						
Input Capacitance	C _{iss}	V _{DS} =50V,V _{GS} =0V,f =1MHz		4200		pF
Output Capacitance	C _{oss}			354		
Reverse Transfer Capacitance	C _{rss}			23		
Total Gate Charge	Q _g	V _{DS} =50V,V _{GS} =10V,I _D =39A		65		nC
Gate-Source Charge	Q _{gs}			15.3		
Gate-Drain Charge	Q _{gd}			9		
Turn-on delay time	t _{d(on)}	V _{DD} =50V, V _{GS} =10V I _D =39A,R _{GEN} =4.7Ω		15		nS
Turn-on rise time	t _r			10		
Turn-off delay time	t _{d(off)}			41		
Turn-off fall time	t _f			6		
Diode Forward Current ¹⁾	I _S				78	A
Diode Forward voltage	V _{DS}	V _{GS} =0V, I _S =78A			1.2	V
Reverse Recovery Time	t _{rr}	T _J = 25°C, I _F = I _S		101		nS
Reverse Recovery Charge	Q _{rr}	di/dt = 100A/μs ¹⁾		193		nC

Notes:

1) Pulse Test: Pulse Width < 300μs, Duty Cycle ≤2%.

2) Guaranteed by design, not subject to production testing.

Test Circuit

1) E_{AS} test Circuit

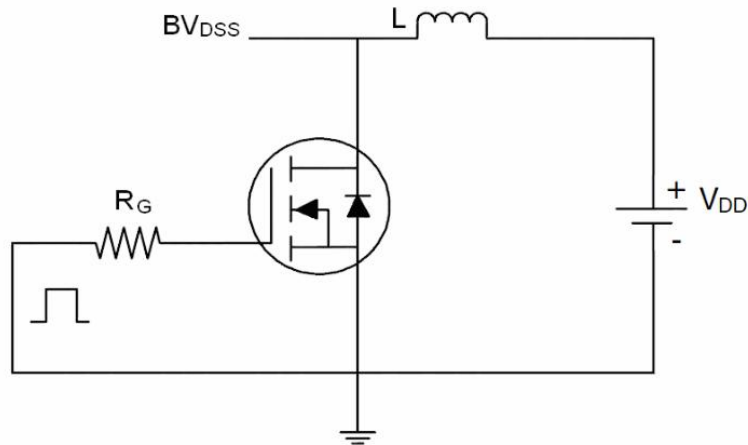

2) Gate charge test Circuit

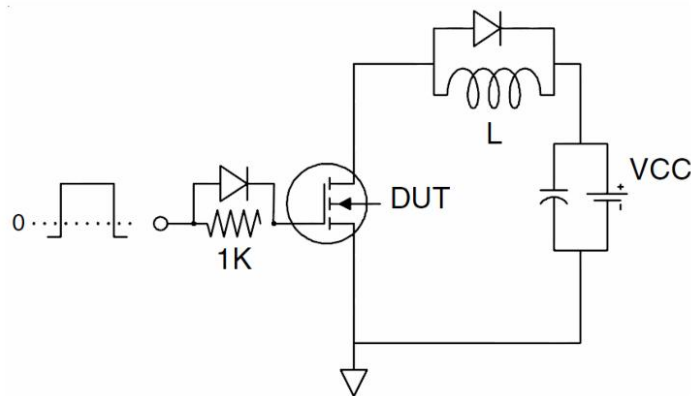

3) Switch Time Test Circuit

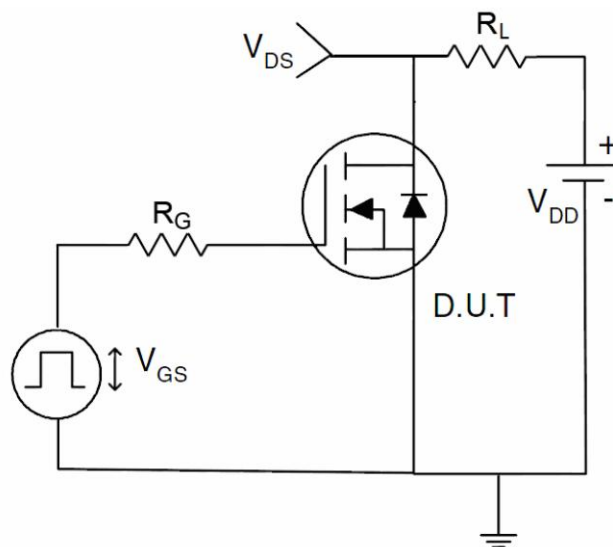

Typical Characteristics

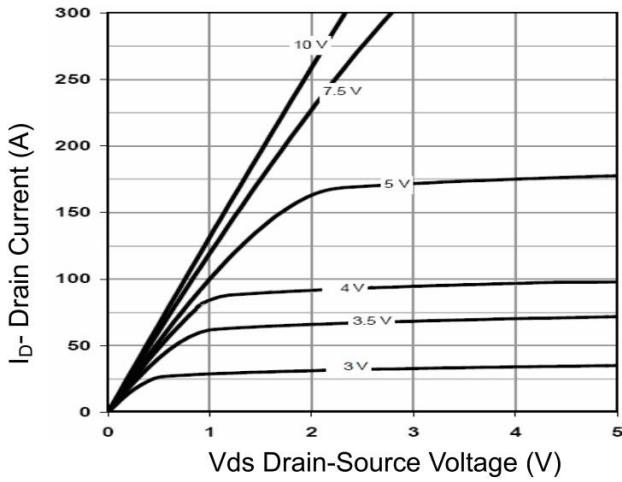

Figure 1 Output Characteristics

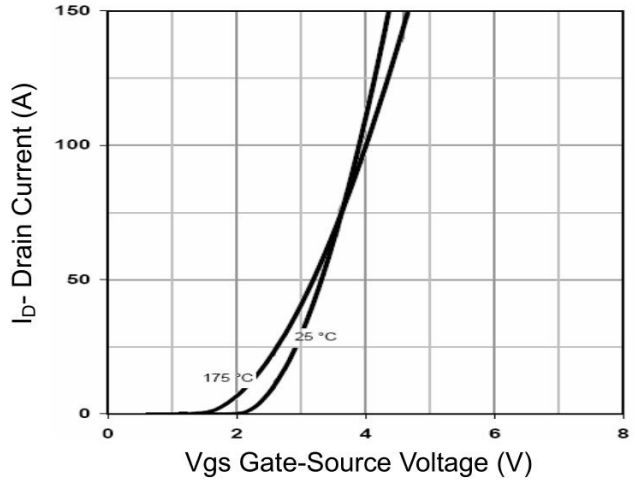

Figure 2 Transfer Characteristics

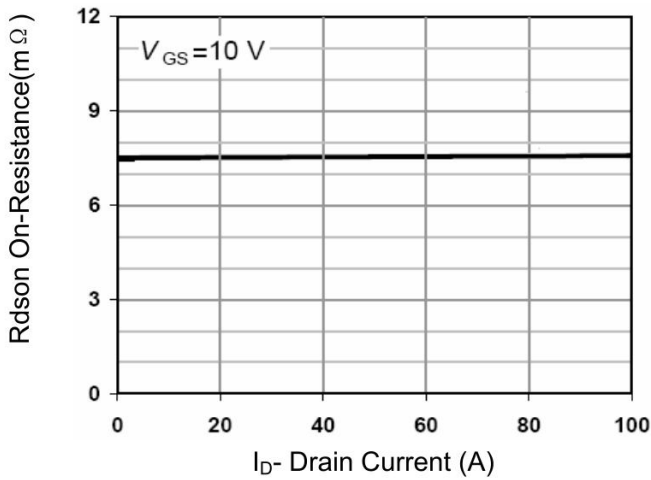

Figure 3 Rdson- Drain Current

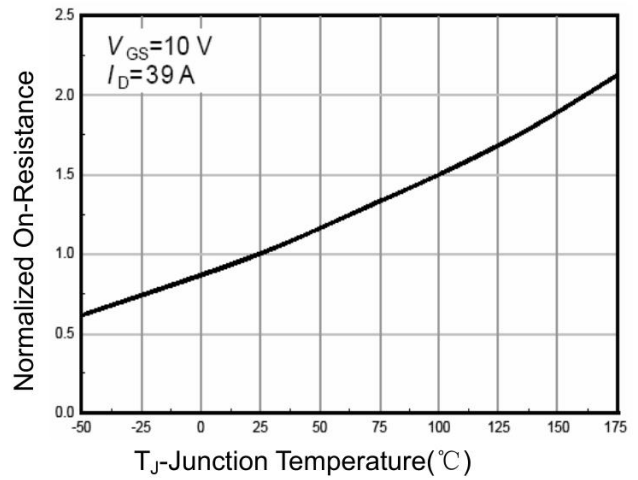

Figure 4 Rdson-Junction Temperature

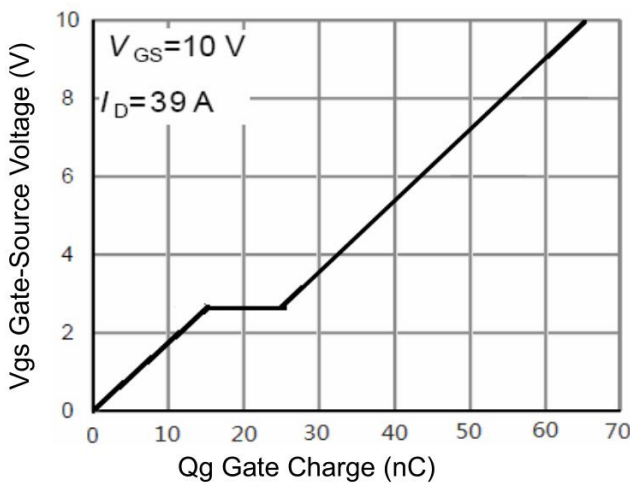

Figure 5 Gate Charge

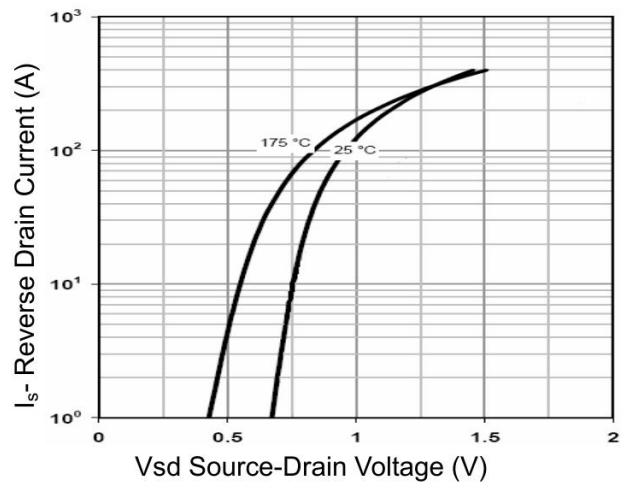

Figure 6 Source- Drain Diode Forward

Typical Characteristics

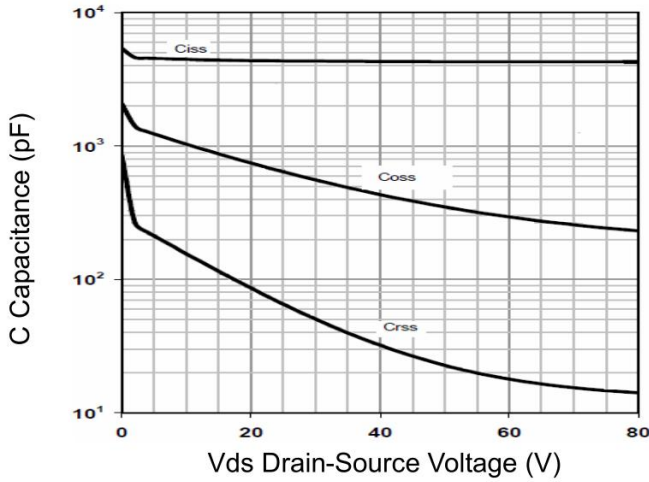

Figure 7 Capacitance vs Vds

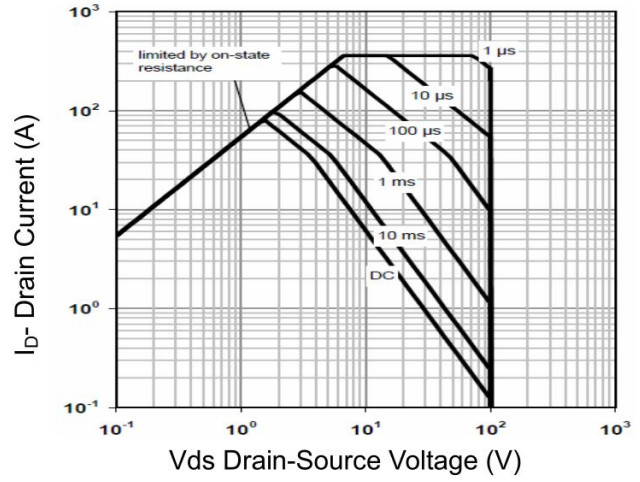

Figure 8 Safe Operation Area

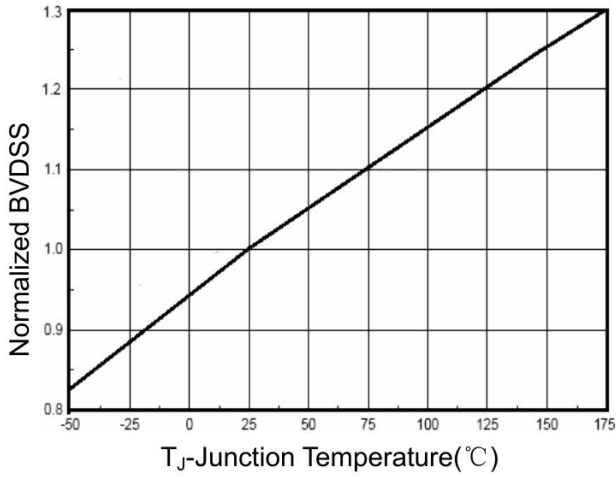

Figure 9 BV_{DSS} vs Junction Temperature

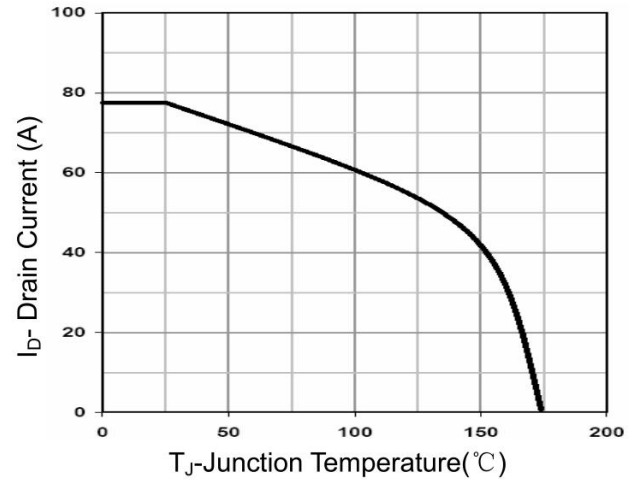

Figure 10 Current De-rating

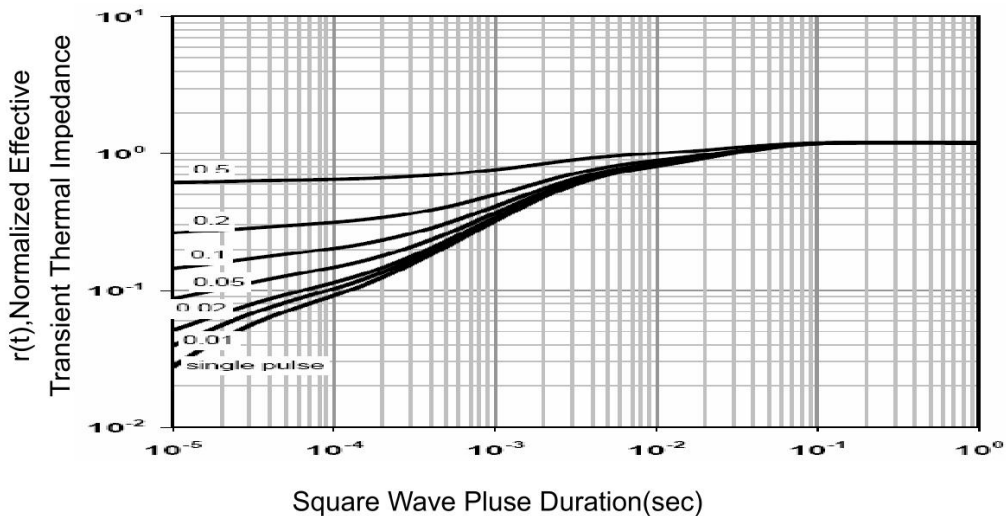
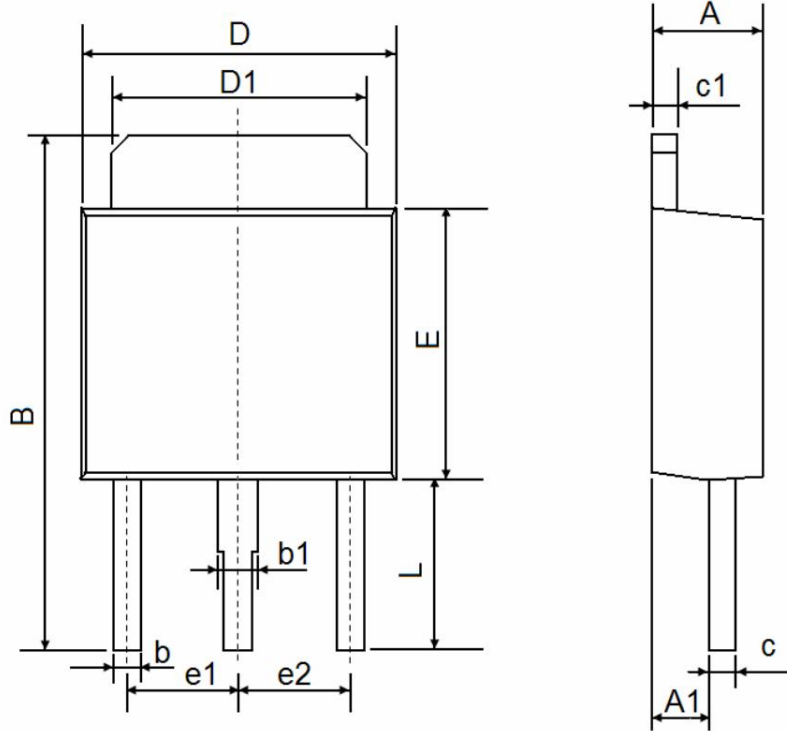

Figure 11 Normalized Maximum Transient Thermal Impedance

TO-251AB Package Information



Symbol	Dimensions In Millimeters		Dimensions In Inches	
	Min.	Max.	Min.	Max.
A	2.250	2.350	0.089	0.093
A1	1.150	1.250	0.045	0.049
B	10.200	10.800	0.402	0.425
b	0.550	0.650	0.022	0.026
b1	0.750	0.850	0.030	0.033
c	0.480	0.540	0.019	0.021
c1	0.480	0.540	0.019	0.021
D	6.400	6.600	0.252	0.260
D1	5.250	5.350	0.207	0.211
E	5.400	5.600	0.213	0.220
e1	2.300 TYP.		0.091 TYP.	
e2	2.300 TYP.		0.091 TYP.	
L	3.300	3.700	0.130	0.146