

Product Summary

$V_{(BR)DSS}$	$R_{DS(on)MAX}$	I_D
150V	300mΩ@10V	2A

Feature

- High density cell design for ultra low Rdson
- Fully characterized avalanche voltage and current
- Excellent package for good heat dissipation
- Suffix "-Q1" for AEC-Q101

Application

- Power switching application
- Hard switched and high frequency circuits

Package

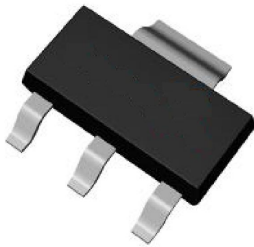

SOT-223

Circuit diagram

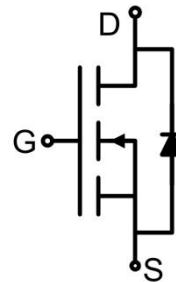

Marking



Absolute maximum ratings (Ta=25°C unless otherwise noted)

Parameter	Symbol	Value	Unit
Drain-Source Voltage	V _{DS}	150	V
Gate-Source Voltage	V _{GS}	±20	V
Continuous Drain Current	I _D	2	A
Pulsed Drain Current ¹⁾	I _{DM}	6	A
Power Dissipation	P _D	2	W
Thermal Resistance from Junction to Ambient ²⁾	R _{θJA}	62.5	°C/W
Junction Temperature	T _J	150	°C
Storage Temperature	T _{STG}	-55 ~ +150	°C

Electrical characteristics (T_A=25°C, unless otherwise noted)

Parameter	Symbol	Test Condition	Min.	Typ.	Max.	Unit
Static Characteristics						
Drain-source breakdown voltage	V _{(BR)DSS}	V _{GS} = 0V, I _D = 250μA	150			V
Zero gate voltage drain current	I _{DSS}	V _{DS} = 150V, V _{GS} = 0V			1	μA
Gate-body leakage current	I _{GSS}	V _{GS} = ±20V, V _{DS} = 0V			±100	nA
Gate threshold voltage ³⁾	V _{GS(th)}	V _{DS} = V _{GS} , I _D = 250μA	1.5	2.0	2.5	V
Drain-source on-resistance ³⁾	R _{DS(on)}	V _{GS} = 10V, I _D = 1.5A		260	300	mΩ
Forward Transconductance ³⁾	g _{FS}	V _{DS} = 15V, I _D = 1.5A		3		S
Dynamic characteristics⁴⁾						
Input Capacitance	C _{iss}	V _{DS} = 25V, V _{GS} = 0V, f = 1MHz		235		pF
Output Capacitance	C _{oss}			36		
Reverse Transfer Capacitance	C _{rss}			20		
Total Gate Charge	Q _g	V _{DS} = 75V, V _{GS} = 10V, I _D = 1.5A		8		nC
Gate-Source Charge	Q _{gs}			1.4		
Gate-Drain Charge	Q _{gd}			2.1		
Turn-on delay time	t _{d(on)}	V _{DD} = 75V, V _{GS} = 10V, I _D = 1A R _L = 75Ω, R _G = 6Ω		8		nS
Turn-on rise time	t _r			10		
Turn-off delay time	t _{d(off)}			20		
Turn-off fall time	t _f			15		
Source-Drain Diode characteristics						
Diode Forward Voltage ³⁾	V _{SD}	V _{GS} = 0V, I _S = 2A			1.2	V
Diode Forward Current ²⁾	I _S				2	A

Notes:

- 1) Repetitive Rating: Pulse width limited by maximum junction temperature
- 2) Surface Mounted on FR4 Board, t ≤ 10 sec.
- 3) Pulse Test: Pulse Width ≤ 300μs, Duty Cycle ≤ 2%.
- 4) Guaranteed by design, not subject to production.

Typical Characteristics

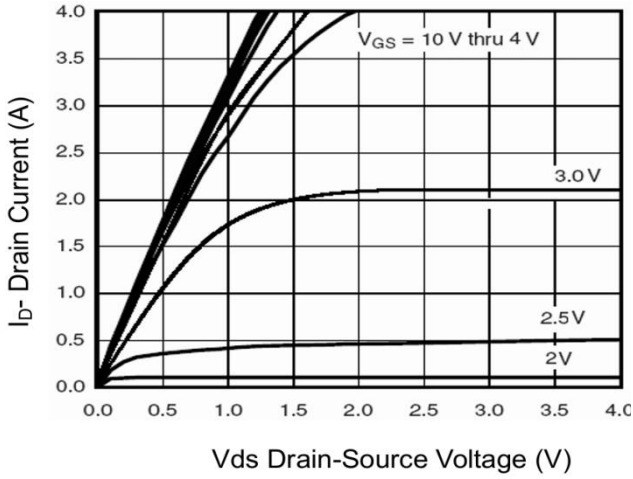

Figure 1 Output Characteristics

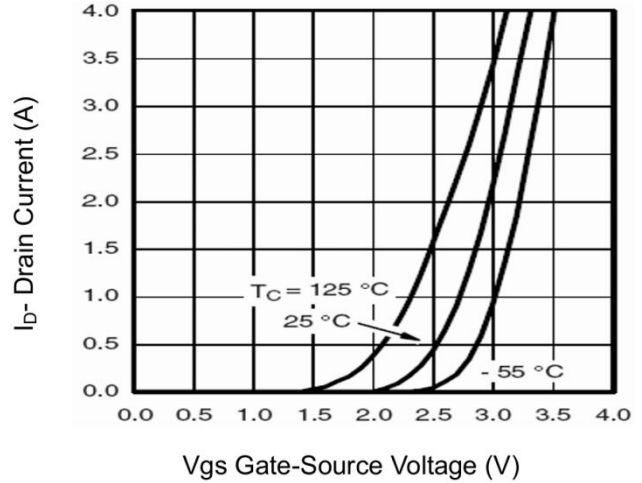

Figure 2 Transfer Characteristics

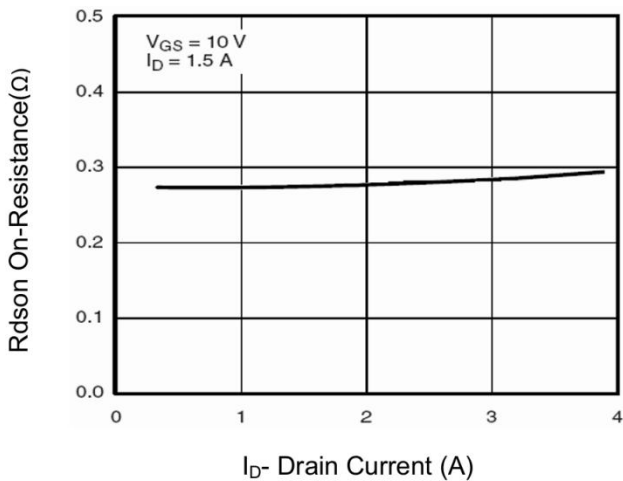

Figure 3 Rdson- Drain Current

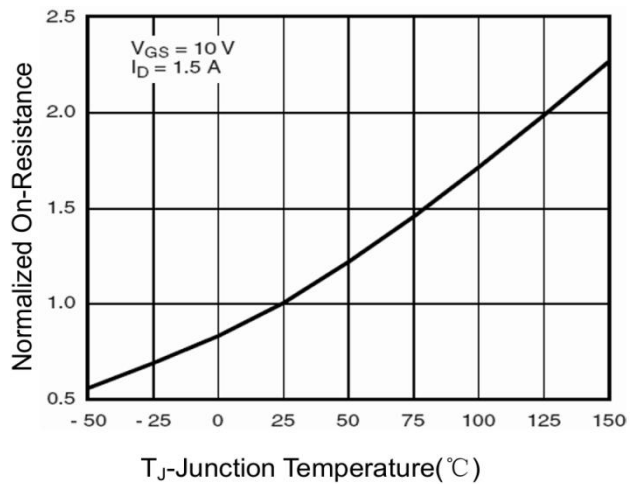

Figure 4 Rdson- Junction Temperature

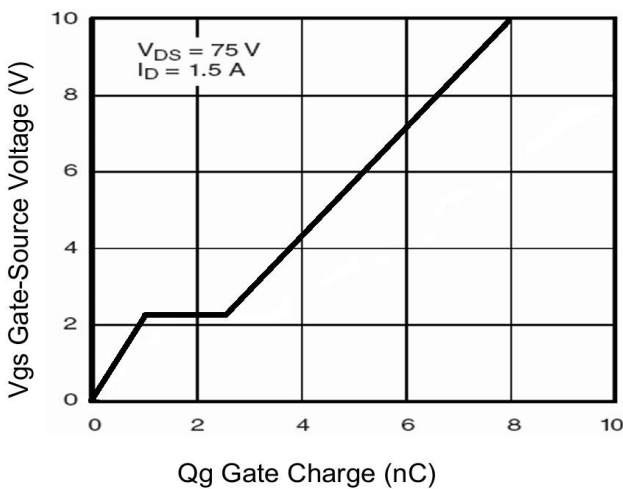

Figure 5 Gate Charge

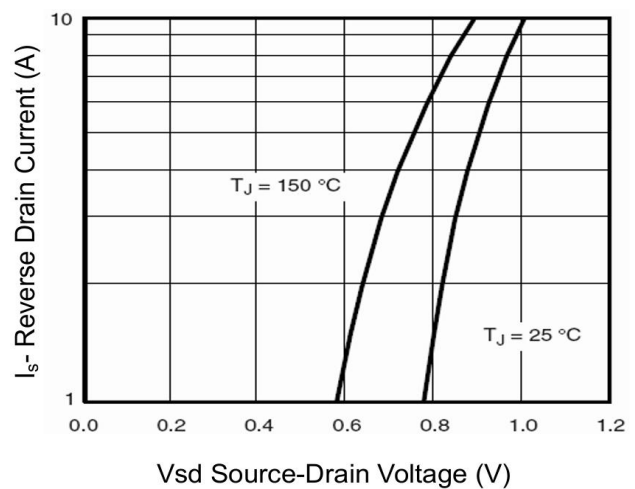

Figure 6 Source- Drain Diode Forward

Typical Characteristics

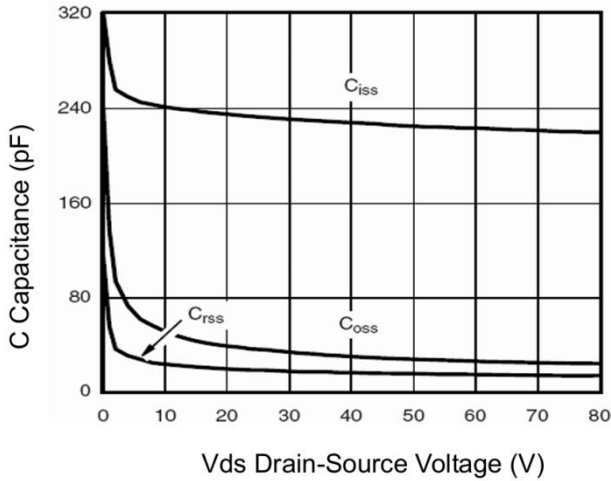

Figure 7 Capacitance vs Vds

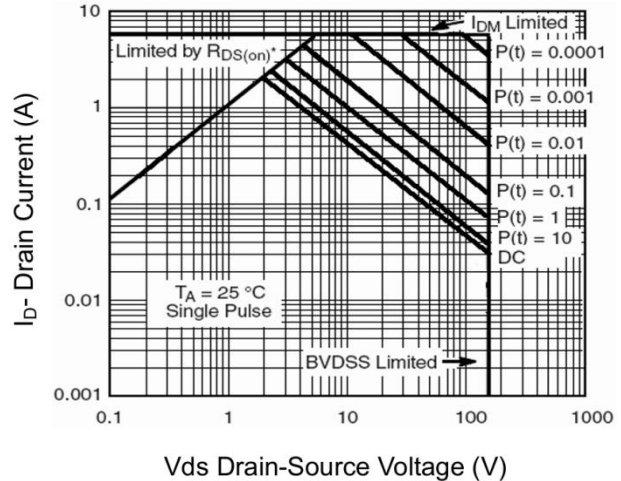

Figure 8 Safe Operation Area

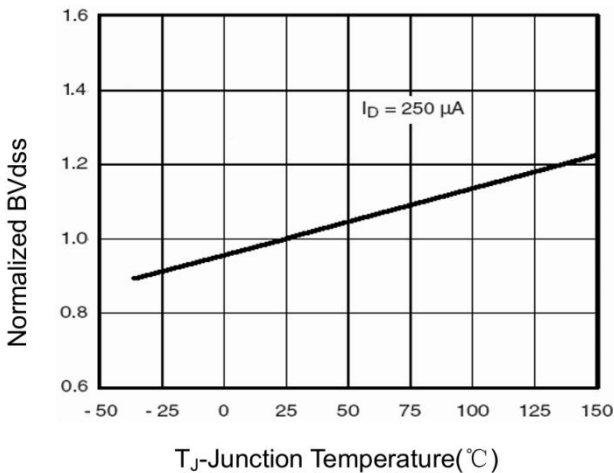

Figure 9 BV_{DSS} vs Junction Temperature

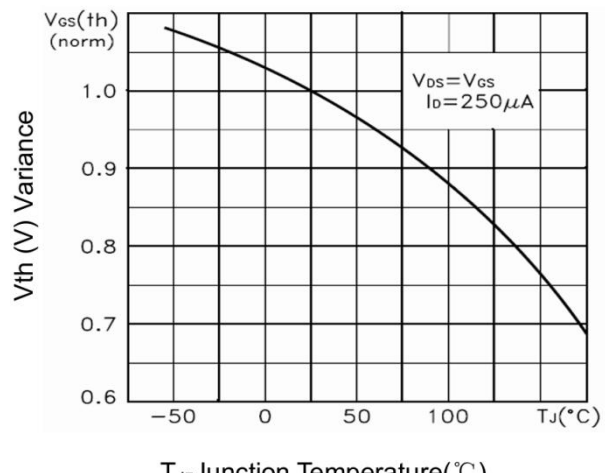

Figure 10 V_{GS(th)} vs Junction Temperature

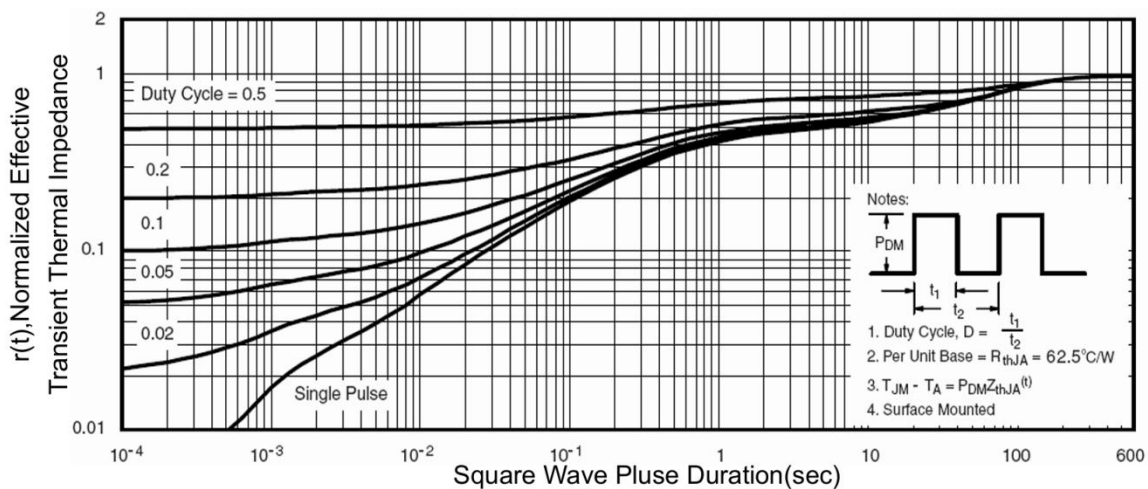
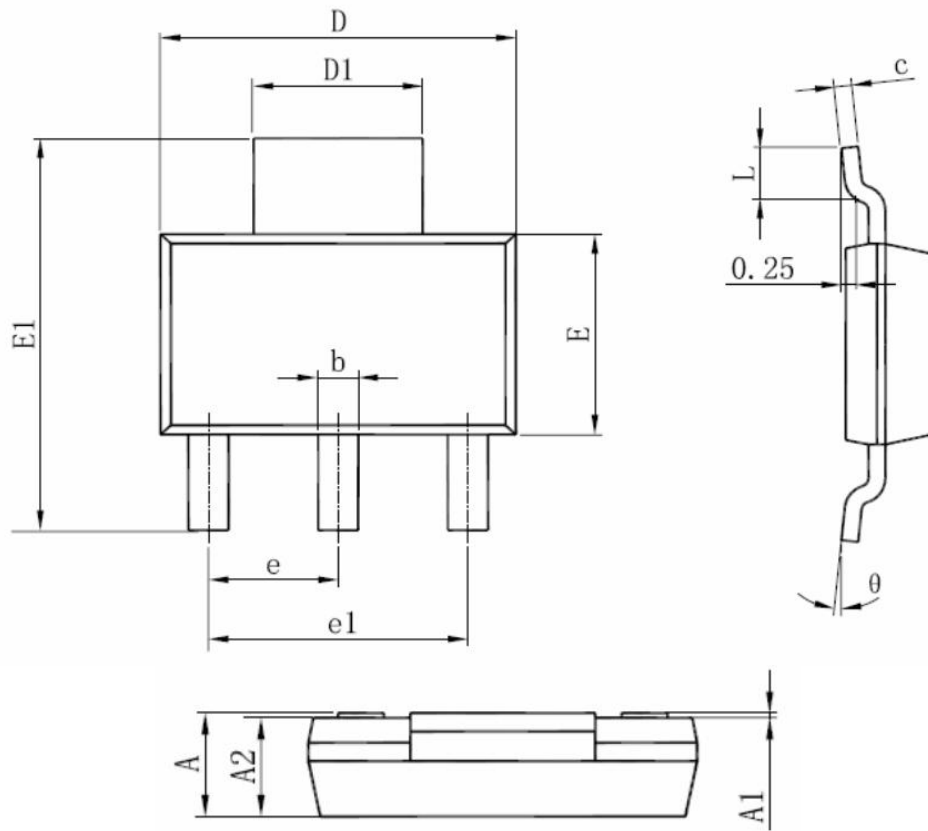

Figure 11 Normalized Maximum Transient Thermal Impedance

SOT-223 Package Information



Symbol	Dimensions In Millimeters		Dimensions In Inches	
	Min.	Max.	Min.	Max.
A	1.520	1.800	0.060	0.071
A1	0.000	0.120	0.000	0.005
A2	1.450	1.750	0.057	0.069
b	0.600	0.820	0.024	0.032
c	0.240	0.350	0.010	0.014
D	6.200	6.500	0.244	0.256
D1	2.900	3.100	0.114	0.122
E	3.300	3.700	0.130	0.146
E1	6.700	7.300	0.264	0.287
e	2.300(BSC)		0.091(BSC)	
e1	4.500	4.700	0.177	0.185
L	0.900	1.150	0.035	0.045
θ	0°	10°	0°	10°