

Product Summary

$V_{(BR)DSS}$	$R_{DS(on)MAX}$	I_D
100V	110mΩ@10V	4A
	120mΩ@4.5V	

Feature

- High density cell design for ultra low $R_{DS(ON)}$
- Trench Power MV MOSFET technology
- Excellent package for good heat dissipation
- Suffix "-Q1" for AEC-Q101

Application

- DC-DC Converters
- Power management functions

Package

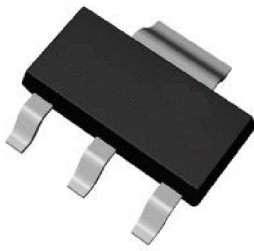

SOT-223

Circuit diagram

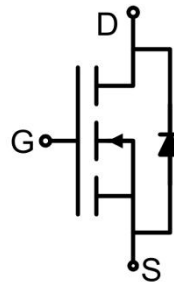

Marking

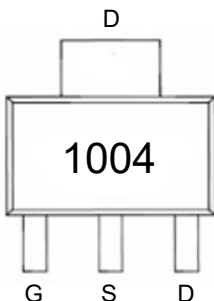

Absolute maximum ratings (Ta=25°C unless otherwise noted)

Parameter	Symbol	Value	Unit
Drain-Source Voltage	V_{DS}	100	V
Gate-Source Voltage	V_{GS}	±20	V
Continuous Drain Current	I_D	4	A
Pulsed Drain Current	I_{DM}	16	A
Power Dissipation	P_D	2.5	W
Thermal Resistance from Junction to Ambient	$R_{\theta JA}$	50	°C/W
Junction Temperature	T_J	150	°C
Storage Temperature	T_{STG}	-55 ~ +150	°C

Electrical characteristics (Ta=25 °C, unless otherwise noted)

Parameter	Symbol	Test Condition	Min.	Typ.	Max.	Unit
Static Characteristics						
Drain-source breakdown voltage	$V_{(BR)DSS}$	$V_{GS} = 0V, I_D = 250\mu A$	100			V
Zero gate voltage drain current	I_{DSS}	$V_{DS} = 100V, V_{GS} = 0V$			1	μA
Gate-body leakage current	I_{GSS}	$V_{GS} = \pm 20V, V_{DS} = 0V$			±100	nA
Gate threshold voltage	$V_{GS(th)}$	$V_{DS} = V_{GS}, I_D = 250\mu A$	1.1		3.0	V
Drain-source on-resistance ¹⁾	$R_{DS(on)}$	$V_{GS} = 10V, I_D = 4.0A$			110	mΩ
		$V_{GS} = 4.5V, I_D = 3.2A$			120	
Dynamic characteristics²⁾						
Input Capacitance	C_{iss}	$V_{DS} = 50V, V_{GS} = 0V, f = 1MHz$		800		pF
Output Capacitance	C_{oss}			40		
Reverse Transfer Capacitance	C_{rss}			32		
Total Gate Charge	Q_g	$V_{DS} = 50V, V_{GS} = 10V, I_D = 4A$		16		nC
Gate-Source Charge	Q_{gs}			2.5		
Gate-Drain Charge	Q_{gd}			2.6		
Turn-on delay time	$t_{d(on)}$	$V_{DD} = 50V, V_{GS} = 10V, R_L = 6.4\Omega, R_{GEN} = 3\Omega$		6		nS
Turn-on rise time	t_r			41		
Turn-off delay time	$t_{d(off)}$			25		
Turn-off fall time	t_f			8		
Source-Drain Diode characteristics						
Diode Forward Current ¹⁾	I_S				4	A
Diode Forward voltage	V_{DS}	$V_{GS} = 0V, I_S = 4A$			1.2	V

Notes:

- 1) Pulse Test: Pulse Width < 300μs, Duty Cycle ≤2%.
- 2) Guaranteed by design, not subject to production testing.

Typical Characteristics

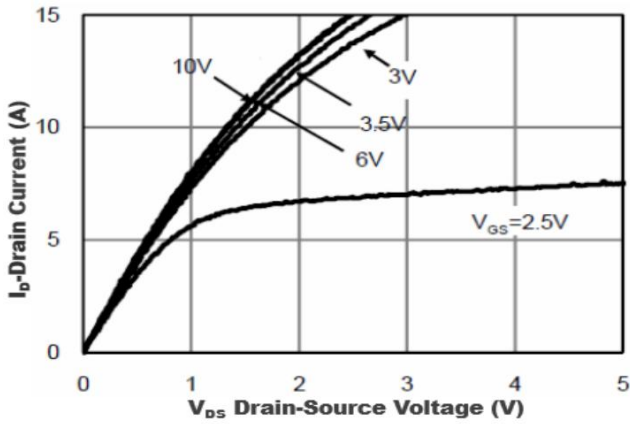

Figure1. Output Characteristics

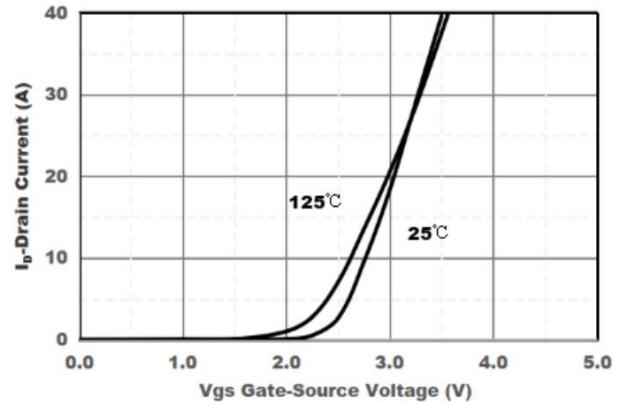

Figure2. Transfer Characteristics

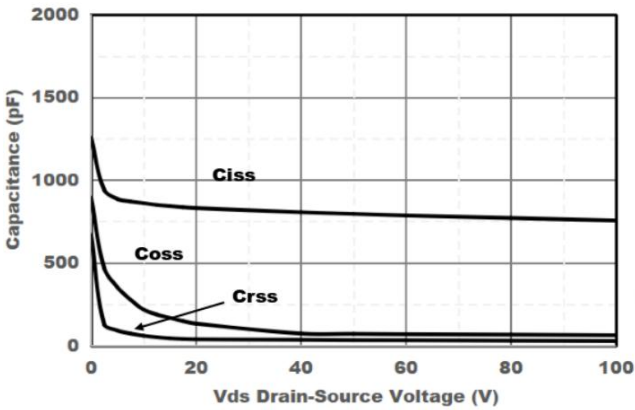

Figure3. Capacitance Characteristics

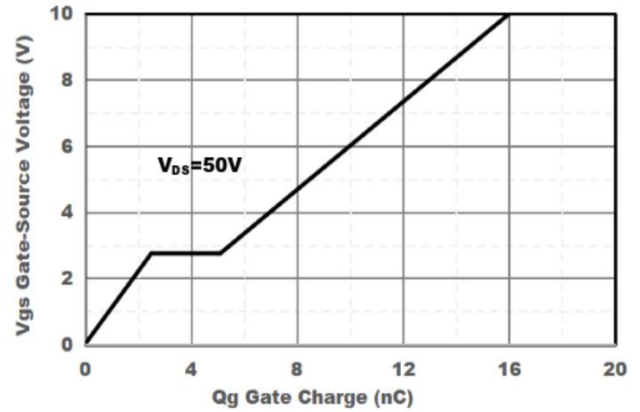

Figure4. Gate Charge

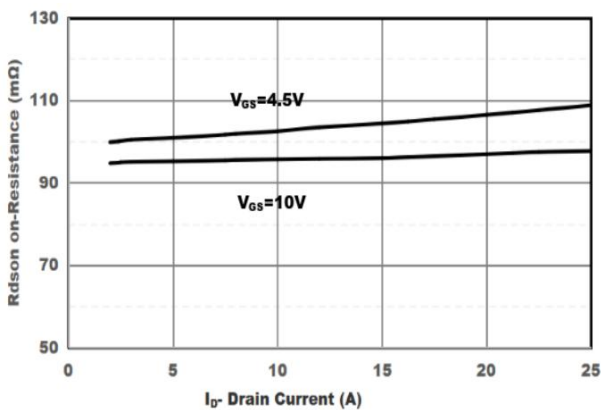

Figure5. Drain-Source on Resistance

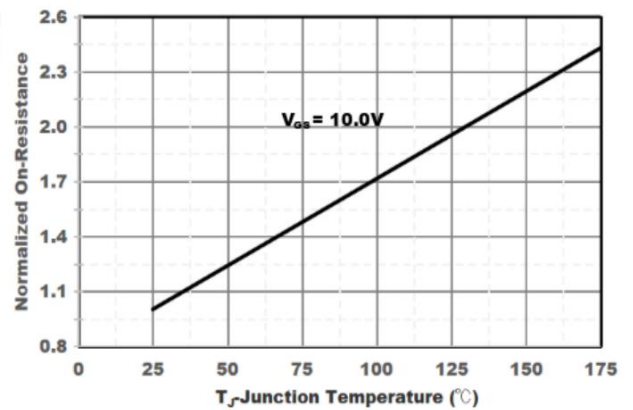
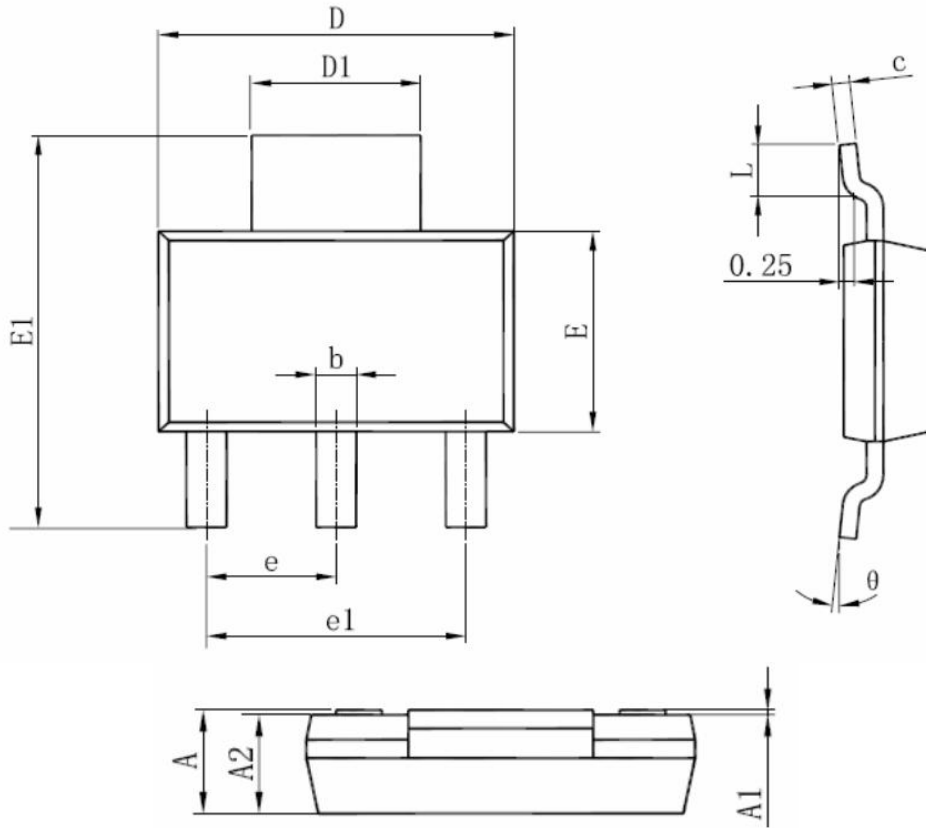

Figure6. Drain-Source on Resistance

SOT-223 Package Information



Symbol	Dimensions In Millimeters		Dimensions In Inches	
	Min.	Max.	Min.	Max.
A	1.520	1.800	0.060	0.071
A1	0.000	0.100	0.000	0.004
A2	1.500	1.700	0.059	0.067
b	0.660	0.820	0.026	0.032
c	0.250	0.350	0.010	0.014
D	6.200	6.400	0.244	0.252
D1	2.900	3.100	0.114	0.122
E	3.300	3.700	0.130	0.146
E1	6.830	7.070	0.269	0.278
e	2.300(BSC)		0.091(BSC)	
e1	4.500	4.700	0.177	0.185
L	0.900	1.150	0.035	0.045
θ	0°	10°	0°	10°