

FEATURES

- For general AF applications
- High collector current
- High current gain
- Low collector-emitter saturation voltage
- Complementary types: BC807 (PNP)
- Compliant to Halogen-free
- Suffix "-Q1" for AEC-Q101

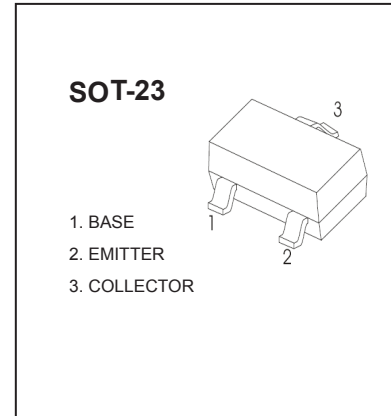

MAXIMUM RATINGS (T_a=25°C unless otherwise noted)

Symbol	Parameter	Value	Unit
V _{CBO}	Collector-Base Voltage	50	V
V _{CEO}	Collector-Emitter Voltage	45	V
V _{EBO}	Emitter-Base Voltage	5	V
I _C	Collector Current -Continuous	0.5	A
P _C	Collector Power Dissipation	0.3	W
T _j	Junction Temperature	150	°C
T _{stg}	Storage Temperature	-55-150	°C

ELECTRICAL CHARACTERISTICS (T_a=25°C unless otherwise specified)

Parameter	Symbol	Test conditions	Min	Typ	Max	Unit
Collector-base breakdown voltage	V _{CBO}	I _C = 10μA, I _E =0	50			V
Collector-emitter breakdown voltage	V _{CEO}	I _C = 10mA, I _B =0	45			V
Emitter-base breakdown voltage	V _{EBO}	I _E = 1μA, I _C =0	5			V
Collector cut-off current	I _{CBO}	V _{CB} = 45 V, I _E =0			0.1	μA
Emitter cut-off current	I _{EBO}	V _{EB} = 4V, I _C =0			0.1	μA
DC current gain	h _{FE(1)}	V _{CE} = 1V, I _C = 100mA	100		600	
	h _{FE(2)}	V _{CE} = 1V, I _C = 500mA	40			
Collector-emitter saturation voltage	V _{CE(sat)}	I _C = 500mA, I _B = 50mA			0.7	V
Base-emitter saturation voltage	V _{BE(sat)}	I _C = 500mA, I _B = 50mA			1.2	V
Base-emitter voltage	V _{BE}	V _{CE} = 1 V, I _C = 500mA			1.2	V
Collector capacitance	C _{ob}	V _{CB} =10V, f=1MHz		10		pF
Transition frequency	f _T	V _{CE} = 5 V, I _C = 10mA f=100MHz	100			MHz

CLASSIFICATION OF h_{FE(1)}

Rank	BC817-16-Q1	BC817-25-Q1	BC817-40-Q1
Range	100-250	160-400	250-600
Marking	6A	6B	6C

Typical Characteristics

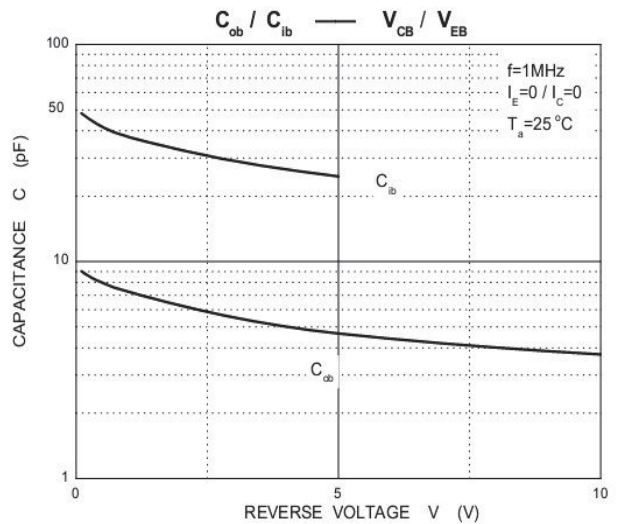
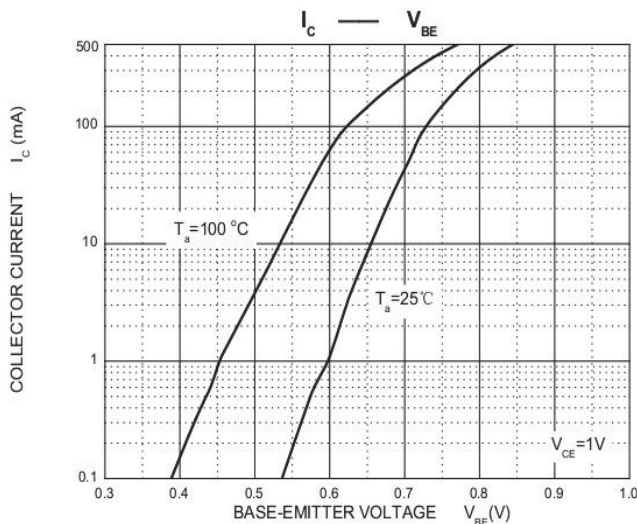
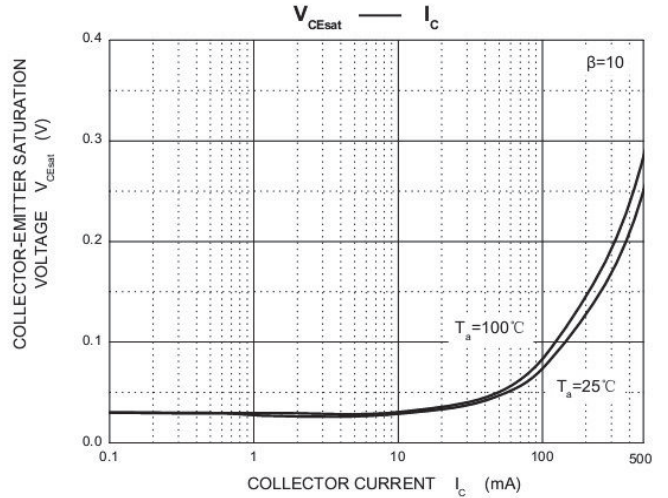
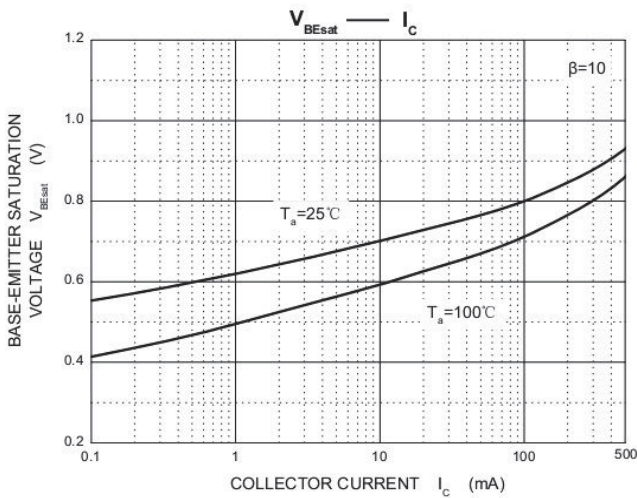
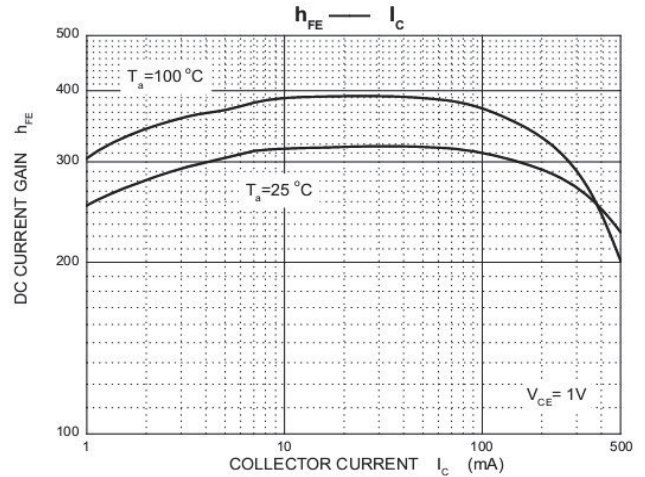
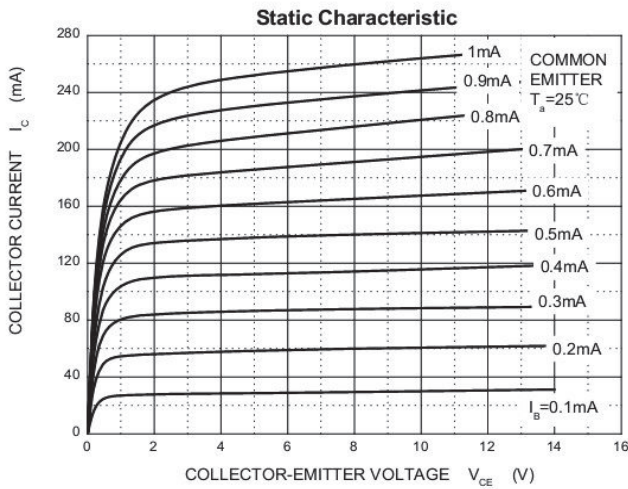

Typical Characteristics

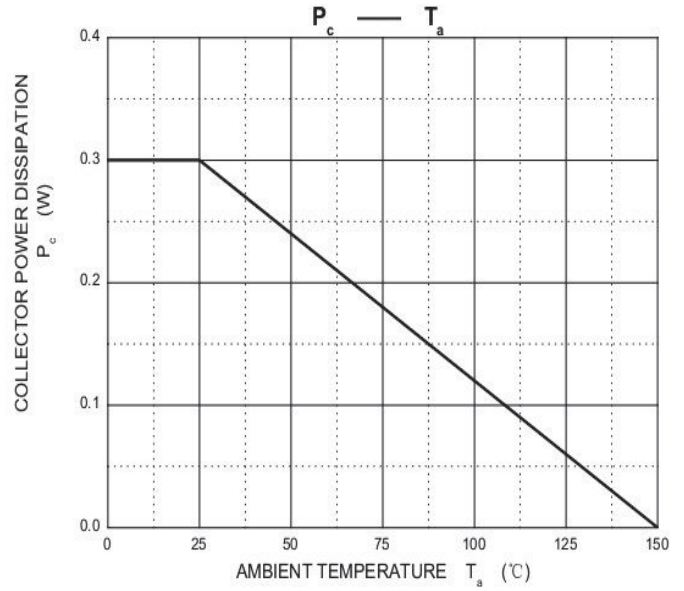
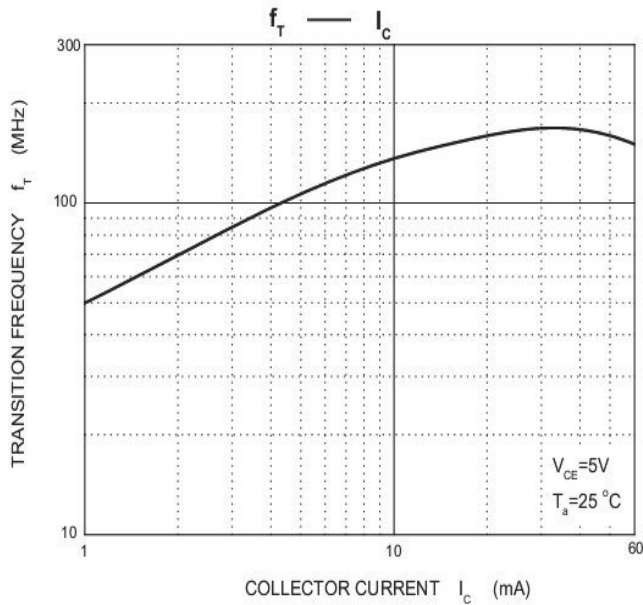

SOT-23 Package Outline Dimensions

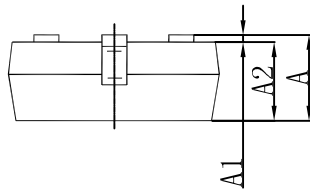
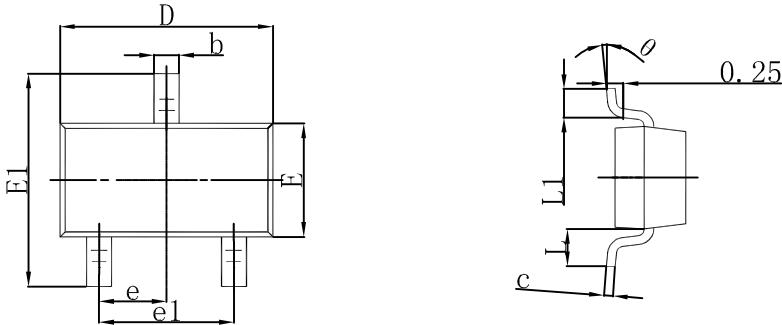

Symbol	Dimensions In Millimeters		Dimensions In Inches	
	Min	Max	Min	Max
A	0.900	1.150	0.035	0.045
A1	0.000	0.100	0.000	0.004
A2	0.900	1.050	0.035	0.041
b	0.300	0.500	0.012	0.020
c	0.080	0.150	0.003	0.006
D	2.800	3.000	0.110	0.118
E	1.200	1.400	0.047	0.055
E1	2.250	2.550	0.089	0.100
e	0.950 TYP		0.037 TYP	
e1	1.800	2.000	0.071	0.079
L	0.550 REF		0.022 REF	
L1	0.300	0.500	0.012	0.020
θ	0°	8°	0°	6°

SOT-23 Suggested Pad Layout

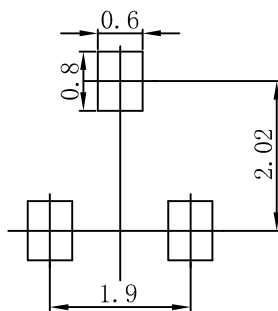

- Note:
1. Controlling dimension: in millimeters.
 2. General tolerance: $\pm 0.05\text{mm}$.
 3. The pad layout is for reference purposes only.