

Product Summary

$V_{(BR)DSS}$	$R_{DS(on)MAX}$	I_D
50V	2.5Ω@10V	0.34A
	3Ω@4.5V	

Feature

- Trench power MV MOSFET technology
- Voltage controlled small signal switch
- Low input capacitance
- Fast switching speed
- Low input/output leakage

Application

- Battery operated systems
- Solid-state relays
- Direct logic-level interface: TTL/CMOS

Package

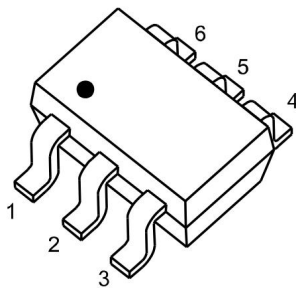

SOT-363

Circuit diagram

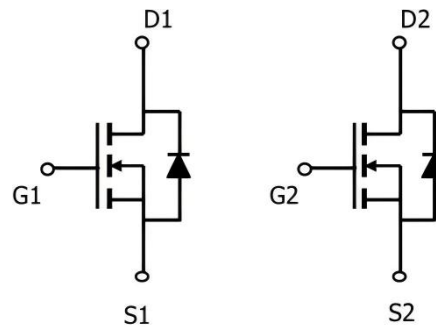

Marking

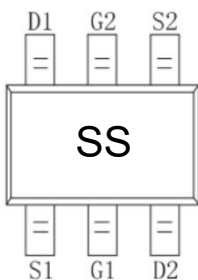

Absolute maximum ratings ($T_A=25^\circ\text{C}$ unless otherwise noted)

Parameter	Symbol	Value	Unit
Drain-Source Voltage	V_{DS}	50	V
Gate-Source Voltage	V_{GS}	± 20	V
Continuous Drain Current	I_D	340	A
Continuous Drain Current ($T_A=70^\circ\text{C}$)	$I_D(70^\circ\text{C})$	272	A
Pulsed Drain Current ¹⁾	I_{DM}	1.5	A
Power Dissipation	P_D	0.35	W
Thermal Resistance Junction to Ambient ²⁾	$R_{\theta JA}$	357	$^\circ\text{C}/\text{W}$
Operating Junction Temperature	T_J	-55 ~ +150	$^\circ\text{C}$
Storage Temperature	T_{STG}	-55 ~ +150	$^\circ\text{C}$

Electrical characteristics ($T_J=25^\circ\text{C}$, unless otherwise noted)

Parameter	Symbol	Test Condition	Min.	Typ.	Max.	Unit
Static Characteristics						
Drain-source breakdown voltage	$V_{(BR)DSS}$	$V_{GS} = 0\text{V}, I_D = 250\mu\text{A}$	50			V
Zero gate voltage drain current	I_{DSS}	$V_{DS} = 50\text{V}, V_{GS} = 0\text{V}$			1	μA
Gate-body leakage current	I_{GSS}	$V_{DS} = 0\text{V}, V_{GS} = \pm 20\text{V}$			± 100	nA
Gate threshold voltage	$V_{GS(th)}$	$V_{DS} = V_{GS}, I_D = 250\mu\text{A}$	0.8	1.2	1.6	V
Drain-source on-resistance	$R_{DS(on)}$	$V_{GS} = 10\text{V}, I_D = 0.3\text{A}$		1.1	2.5	Ω
		$V_{GS} = 4.5\text{V}, I_D = 0.2\text{A}$		1.2	3	
Dynamic characteristics³⁾						
Input Capacitance	C_{iss}	$V_{DS} = 25\text{V}, V_{GS} = 0\text{V}, f = 1\text{MHz}$		28.5		pF
Output Capacitance	C_{oss}			2.7		
Reverse Transfer Capacitance	C_{rss}			1.78		
Total Gate Charge	Q_g	$V_{DS} = 25\text{V}, V_{GS} = 10\text{V}, I_D = 0.3\text{A}$		1.7		nC
Gate-Source Charge	Q_{gs}			0.4		
Gate-Drain Charge	Q_{gd}			0.24		
Turn-on delay time	$t_{d(on)}$	$V_{DS} = 25\text{V}, V_{GS} = 10\text{V}, I_D = 0.3\text{A}$ $R_G = 6\Omega$		2.6		nS
Turn-on rise time	t_r			18.8		
Turn-off delay time	$t_{d(off)}$			9.7		
Turn-off fall time	t_f			47		
Source-Drain Diode characteristics						
Diode Forward Current	I_S				0.34	A
Diode Forward voltage	V_{SD}	$V_{GS} = 0\text{V}, I_S = 0.3\text{A}$			1.2	V
Reverse Recovery Time	T_{rr}	$I_S = 0.3\text{A}, di/dt = -100\text{A}/\mu\text{s}$		12.2		nS
Reverse Recovery Charge	Q_{rr}			2.65		nC

Notes:

- 1) Pulse Test: Pulse Width $\leq 300\mu\text{s}$, Duty Cycle $\leq 2\%$.
- 2) Device mounted on FR-4 PCB, 1 inch x 0.85 inch x 0.062 inch.
- 3) Guaranteed by design, not subject to production testing.

Typical Characteristics

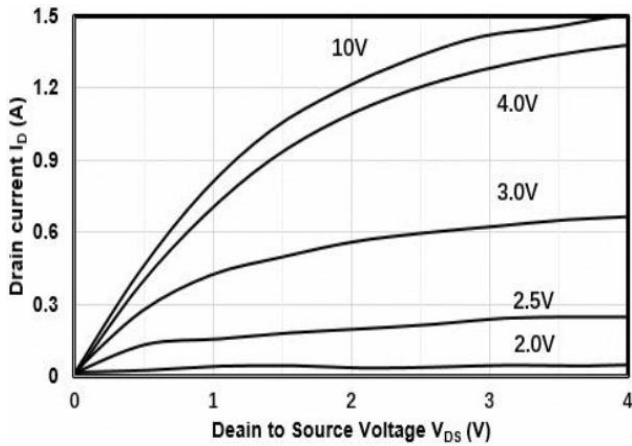

Figure1. Output Characteristics

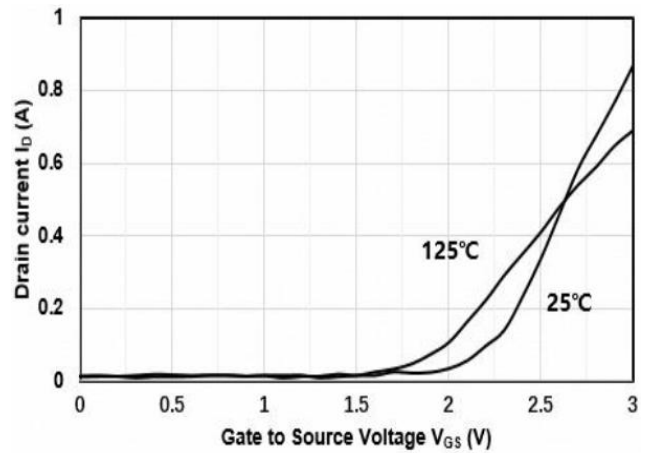

Figure2. Transfer Characteristics

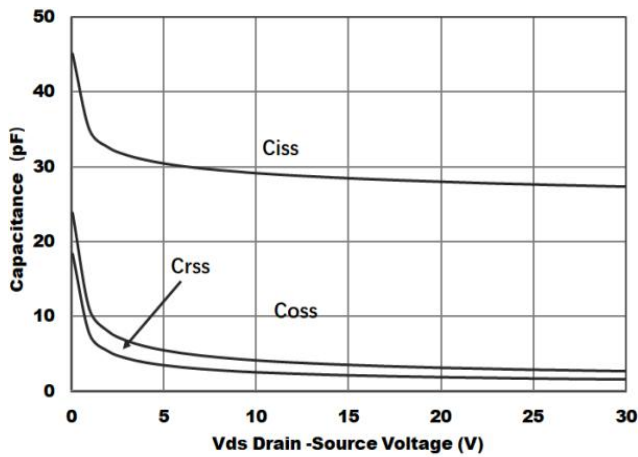

Figure3. Capacitance Characteristics

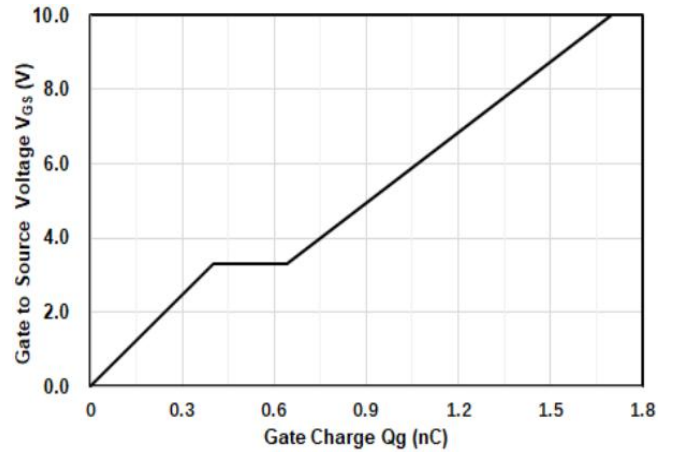

Figure4. Gate Charge

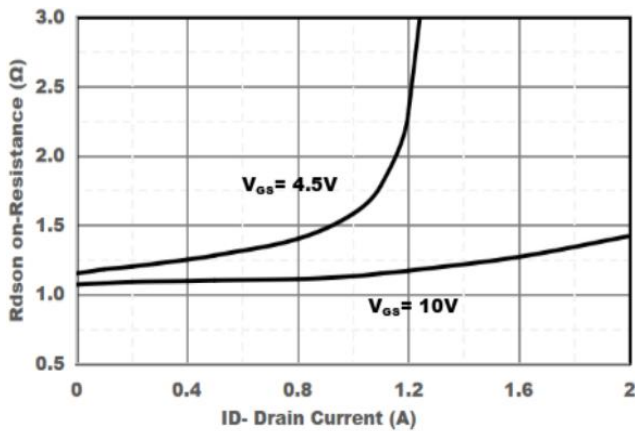

Figure5. Drain-Source on Resistance

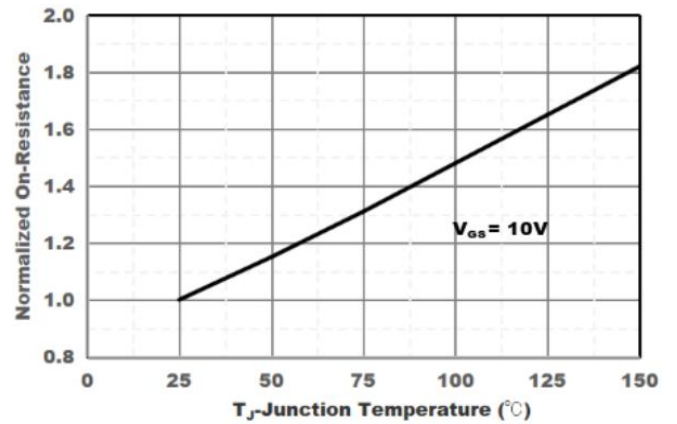

Figure6. Drain-Source on Resistance

Typical Characteristics

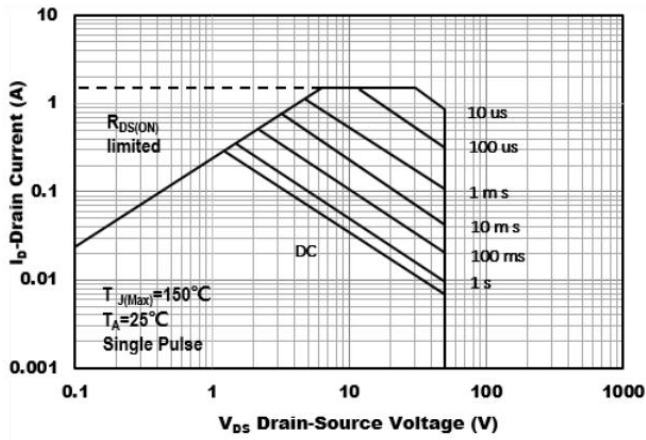

Figure7. Safe Operation Area

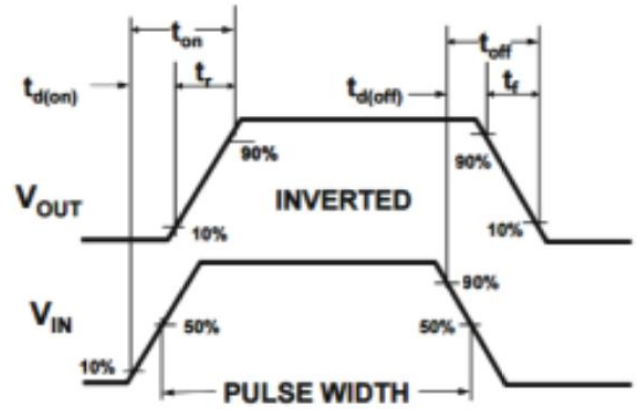
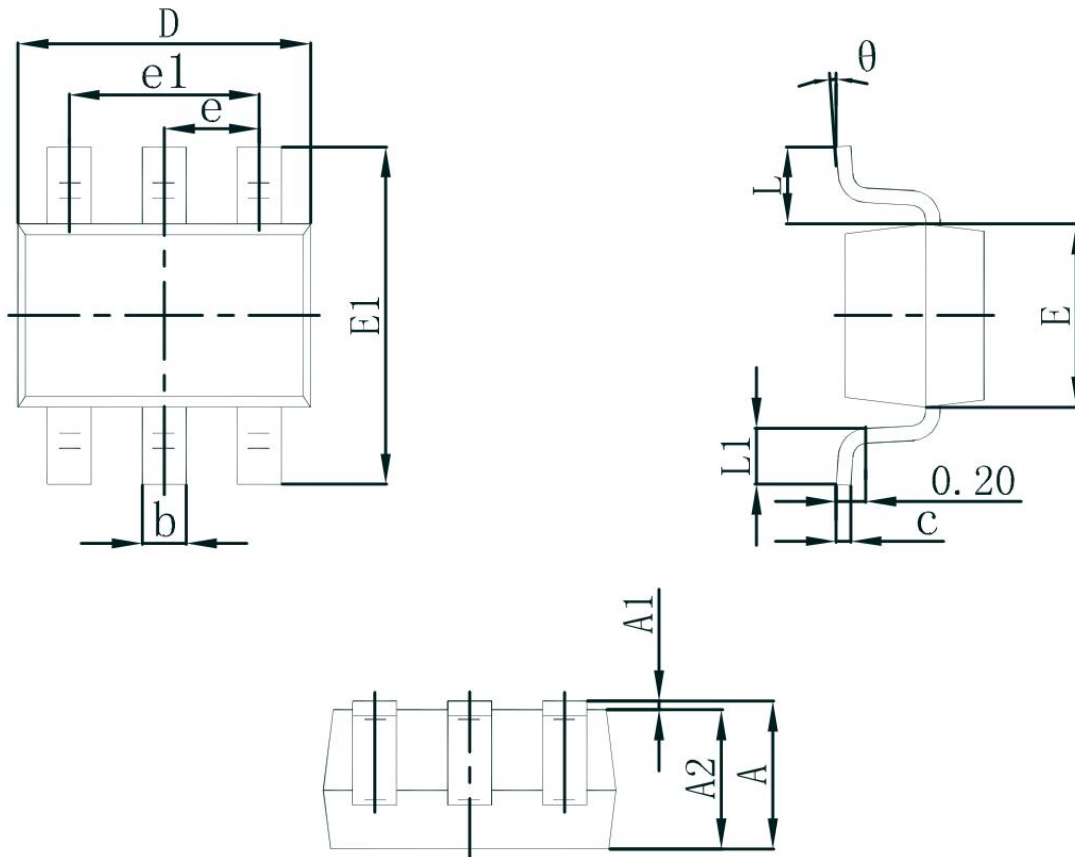

Figure8. Switching wave

SOT-363 Package Information



Symbol	Dimensions In Millimeters		Dimensions In Inches	
	Min.	Max.	Min.	Max.
A	0.900	1.100	0.035	0.043
A1	0.000	0.100	0.000	0.004
A2	0.900	1.000	0.035	0.039
b	0.150	0.350	0.006	0.014
c	0.100	0.250	0.004	0.010
D	1.800	2.200	0.071	0.087
E	1.150	1.350	0.045	0.053
E1	2.150	2.450	0.085	0.096
e	0.650 TYP.		0.026 TYP.	
e1	1.200	1.400	0.047	0.055
L	0.525 REF.		0.021 REF.	
L1	0.260	0.460	0.010	0.018
θ	0°	8°	0°	8°