

Features

- ◆ The plastic package carries Underwriters Laboratory Flammability Classification 94V-0
- ◆ For surface mounted applications
- ◆ Super fast switching for high efficiency
- ◆ Low reverse leakage
- ◆ Built-in strain relief, ideal for automated placement
- ◆ High forward surge current capability
- ◆ High temperature soldering guaranteed: 250°C/10 seconds at terminals
- ◆ Glass passivated chip junction
- ◆ Compliant to RoHS Directive 2011/65/EU
- ◆ Compliant to Halogen-free
- ◆ Suffix "-Q1" for AEC-Q101

Mechanical data

- ◆ **Case:** JEDEC SMBF molded plastic body
- ◆ **Terminals:** Solder plated, solderable per MIL-STD-750, Method 2026
- ◆ **Polarity:** Color band denotes cathode end
- ◆ **Mounting Position:** Any

Package outline

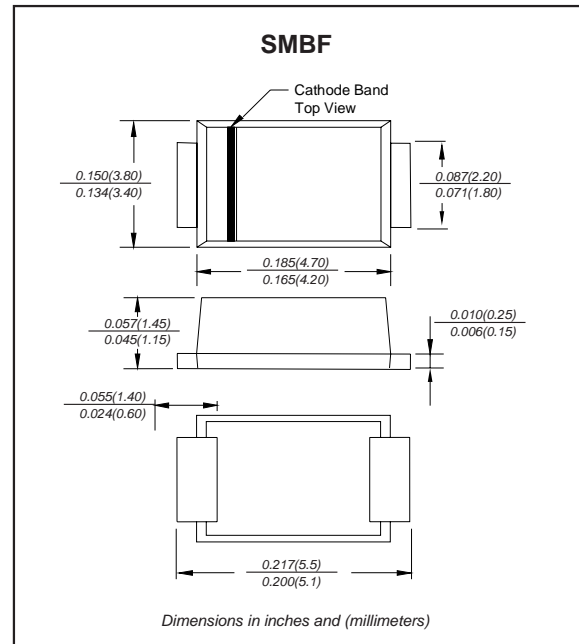

Maximum ratings and Electrical Characteristics (AT $T_A=25^\circ\text{C}$ unless otherwise noted)

PARAMETER	CONDITIONS	Symbol	MIN.	TYP.	MAX.	UNIT
Forward rectified current	See Fig.1	I_O			2.0	A
Forward surge current	8.3ms single half sine-wave (JEDEC method)	I_{FSM}			50	A
Reverse current	$V_R = V_{RRM}$ $T_A = 25^\circ\text{C}$	I_R			5.0	μA
	$V_R = V_{RRM}$ $T_A = 100^\circ\text{C}$				50	
Thermal resistance	Junction to ambient NOTE 1	$R_{\theta JA}$		60		$^\circ\text{C}/\text{W}$
Diode junction capacitance	f=1MHz and applied 4V DC reverse voltage	C_J		28		pF
Storage temperature		T_{STG}	-65		+150	$^\circ\text{C}$

SYMBOLS	V_{RRM}^{*1} (V)	V_{RMS}^{*2} (V)	V_R^{*3} (V)	V_F^{*4} (V)	t_{rr}^{*5} (ns)	Operating temperature T_{Jr} ($^\circ\text{C}$)
ES2A-BF-Q1	50	35	50	0.95	35	-55 to +150
ES2B-BF-Q1	100	70	100			
ES2C-BF-Q1	150	105	150			
ES2D-BF-Q1	200	140	200			
ES2E-BF-Q1	300	210	300	1.25		
ES2G-BF-Q1	400	280	400			
ES2J-BF-Q1	600	420	600			



- *1 Repetitive peak reverse voltage
- *2 RMS voltage
- *3 Continuous reverse voltage
- *4 Maximum forward voltage@ $I_F=2.0\text{A}$
- *5 Maximum Reverse recovery time, note 2

Note: 1.P.C.B. mounted with 2.0x2.0" (5.0x5.0cm) copper pad areas
2. Reverse recovery time test condition, $I_F=0.5\text{A}$, $I_R=1.0\text{A}$, $I_{RR}=0.25\text{A}$

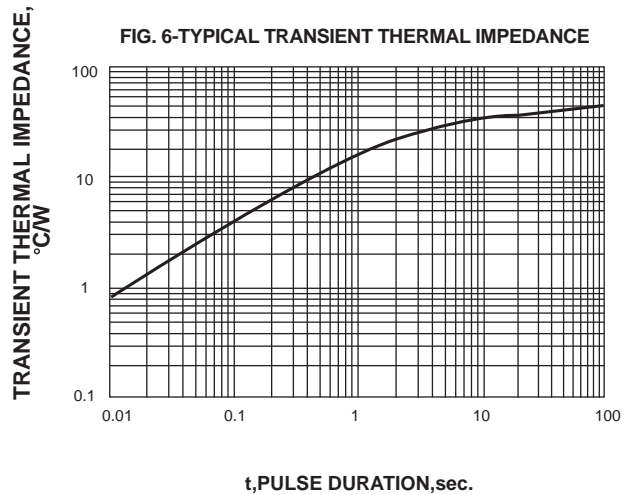
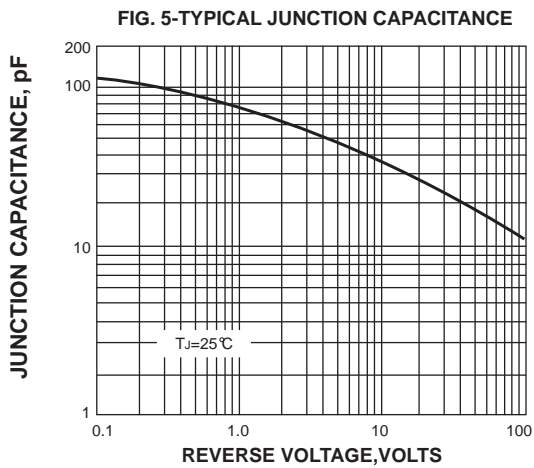
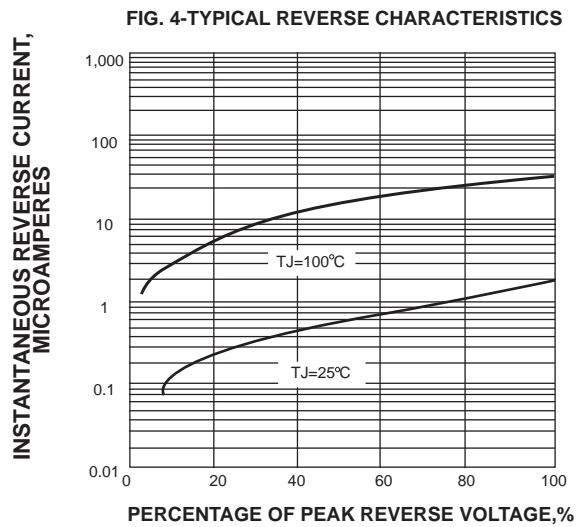
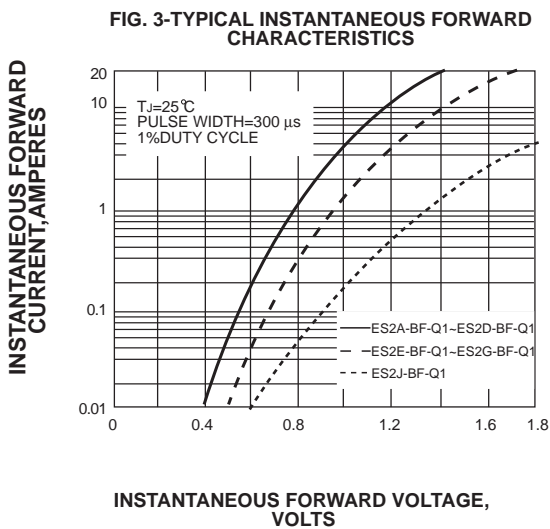
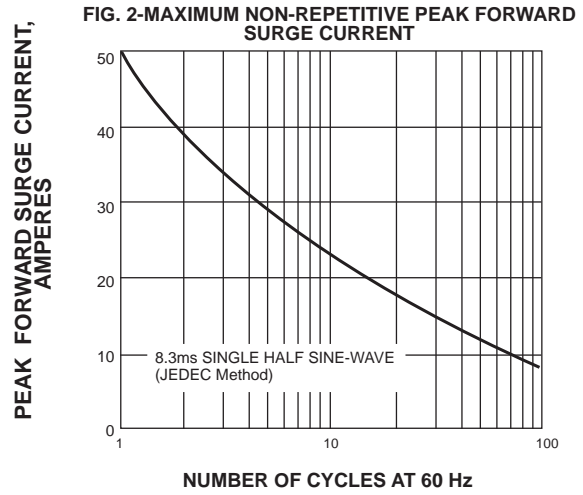
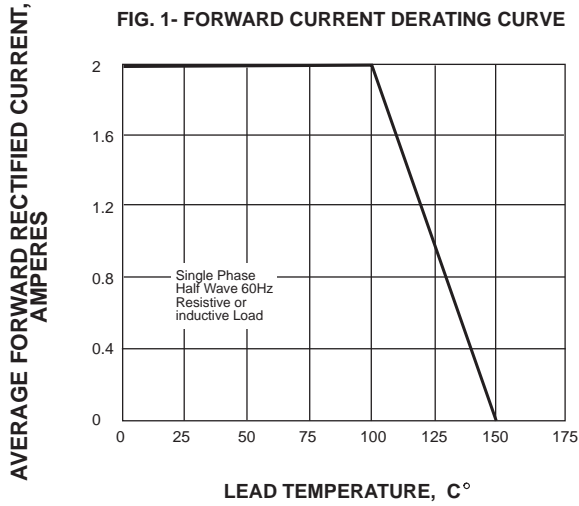
Rating and characteristic curves

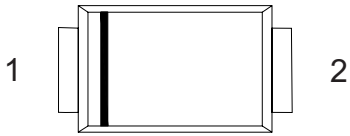

Pinning information

Pin	Simplified outline	Symbol
Pin1 cathode Pin2 anode		

Marking

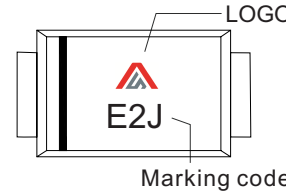
Type number	Marking code	Example
ES2A-BF-Q1	E2A	
ES2B-BF-Q1	E2B	
ES2C-BF-Q1	E2C	
ES2D-BF-Q1	E2D	
ES2E-BF-Q1	E2E	
ES2G-BF-Q1	E2G	
ES2J-BF-Q1	E2J	

Suggested solder pad layout

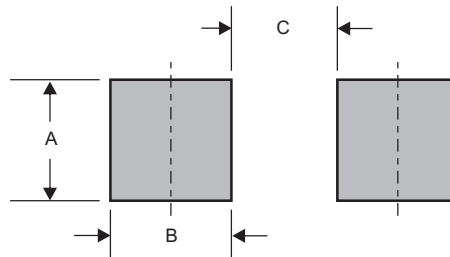

Dimensions in inches and (millimeters)

PACKAGE	A	B	C
SMBF	0.098 (2.50)	0.071 (1.80)	0.118 (3.00)