

### FEATURES

- Complementary Type FMMT593
- Compliant to Halogen-free

### MARKING:493

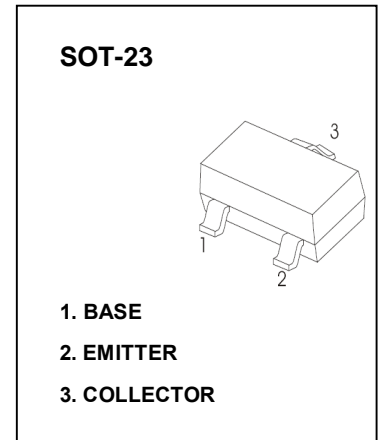

### MAXIMUM RATINGS ( $T_a=25^\circ\text{C}$ unless otherwise noted)

Symbol	Parameter	Value	Unit
$V_{CB0}$	Collector-Base Voltage	120	V
$V_{CEO}$	Collector-Emitter Voltage	100	V
$V_{EBO}$	Emitter-Base Voltage	5	V
$I_C$	Collector Current	1000	mA
$P_C$	Collector Power Dissipation	250	mW
$R_{\theta JA}$	Thermal Resistance From Junction To Ambient	500	$^\circ\text{C/W}$
$T_j$	Junction Temperature	150	$^\circ\text{C}$
$T_{stg}$	Storage Temperature	-55~+150	$^\circ\text{C}$

### ELECTRICAL CHARACTERISTICS ( $T_a=25^\circ\text{C}$ unless otherwise specified)

Parameter	Symbol	Test conditions	Min	Typ	Max	Unit
Collector-base breakdown voltage	$V_{(BR)CBO}$	$I_C=100\mu\text{A}, I_E=0$	120			V
Collector-emitter breakdown voltage	$V_{(BR)CEO}$	$I_C=10\text{mA}, I_B=0$	100			V
Emitter-base breakdown voltage	$V_{(BR)EBO}$	$I_E=100\mu\text{A}, I_C=0$	5			V
Collector cut-off current	$I_{CBO}$	$V_{CB}=100\text{V}, I_E=0$			0.1	$\mu\text{A}$
Collector cut-off current	$I_{CES}$	$V_{CES}=100\text{V}, I_E=0$			0.1	$\mu\text{A}$
Emitter cut-off current	$I_{EBO}$	$V_{EB}=4\text{V}, I_C=0$			0.1	$\mu\text{A}$
DC current gain	$h_{FE(1)}$ *	$V_{CE}=10\text{V}, I_C=1\text{mA}$	100			
	$h_{FE(2)}$ *	$V_{CE}=10\text{V}, I_C=250\text{mA}$	100		300	
	$h_{FE(3)}$ *	$V_{CE}=10\text{V}, I_C=0.5\text{A}$	60			
	$h_{FE(4)}$ *	$V_{CE}=10\text{V}, I_C=1\text{A}$	20			
Collector-emitter saturation voltage	$V_{CE(sat)1}$ *	$I_C=500\text{mA}, I_B=50\text{mA}$			0.3	V
	$V_{CE(sat)2}$ *	$I_C=1\text{A}, I_B=100\text{mA}$			0.6	V
Base-emitter saturation voltage	$V_{BE(sat)}$ *	$I_C=1\text{A}, I_B=100\text{mA}$			1.15	V
Base-emitter voltage	$V_{BE}$ *	$V_{CE}=10\text{V}, I_C=1\text{A}$			1	V
Transition frequency	$f_T$	$V_{CE}=10\text{V}, I_C=50\text{mA}, f=100\text{MHz}$	150			MHz
Collector output capacitance	$C_{ob}$	$V_{CB}=10\text{V}, I_E=0, f=1\text{MHz}$			10	pF

\*Pulse test: pulse width  $\leq 300\mu\text{s}$ , duty cycle  $\leq 2.0\%$ .

### Typical Characteristics

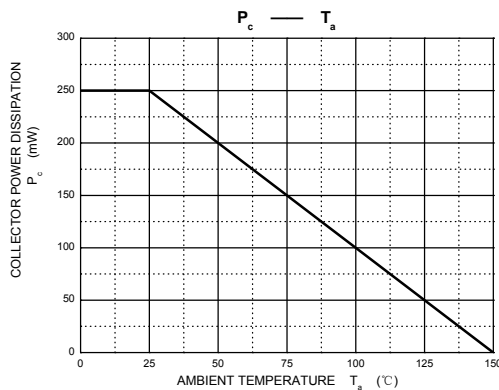
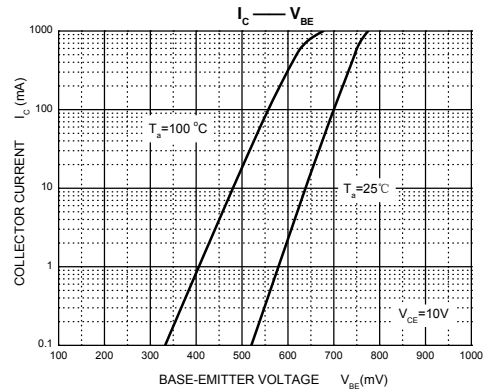
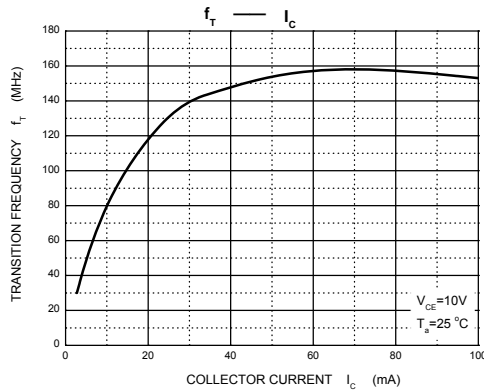
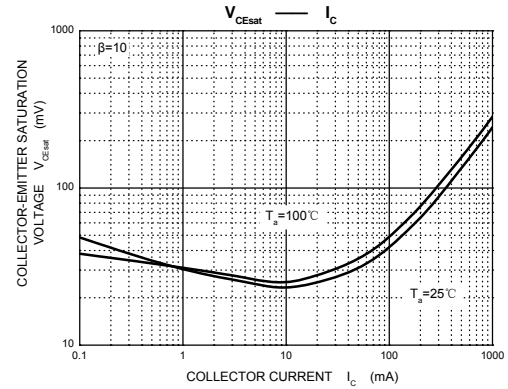
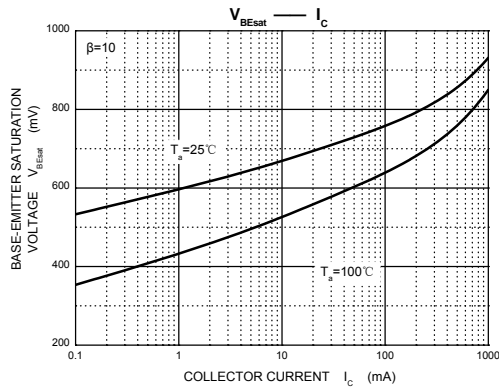
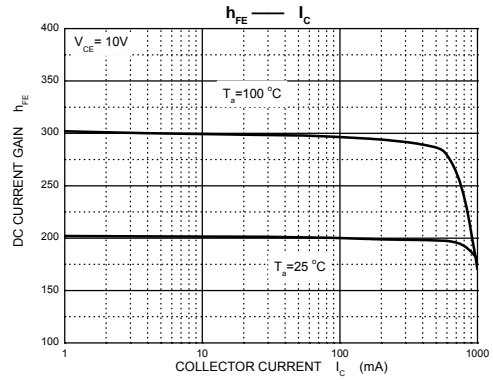
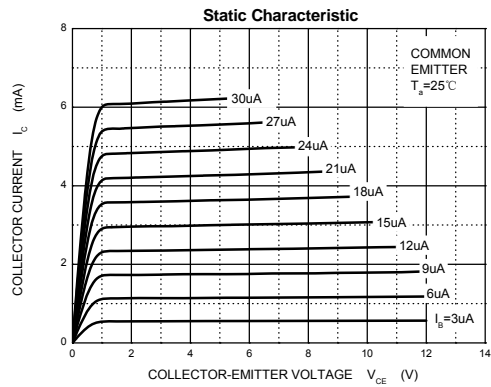

### SOT-23 Package Outline Dimensions

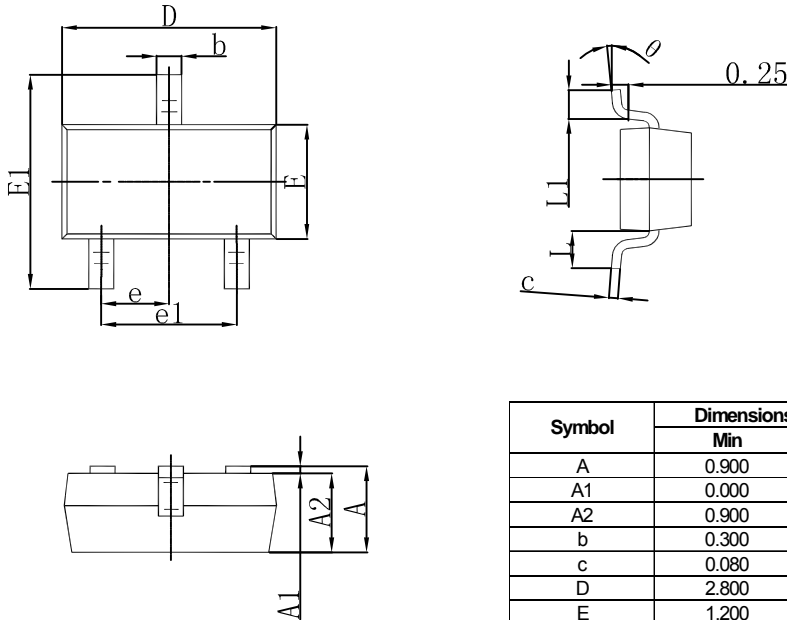

Symbol	Dimensions In Millimeters		Dimensions In Inches	
	Min	Max	Min	Max
A	0.900	1.150	0.035	0.045
A1	0.000	0.100	0.000	0.004
A2	0.900	1.050	0.035	0.041
b	0.300	0.500	0.012	0.020
c	0.080	0.150	0.003	0.006
D	2.800	3.000	0.110	0.118
E	1.200	1.400	0.047	0.055
E1	2.250	2.550	0.089	0.100
e	0.950 TYP		0.037 TYP	
e1	1.800	2.000	0.071	0.079
L	0.550 REF		0.022 REF	
L1	0.300	0.500	0.012	0.020
θ	0°	8°	0°	6°

### SOT-23 Suggested Pad Layout

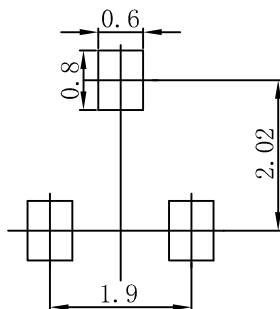

- Note:
1. Controlling dimension: in millimeters.
  2. General tolerance:  $\pm 0.05\text{mm}$ .
  3. The pad layout is for reference purposes only.