

### FEATURES

- ✧ 350 watts peak pulse power per line ( $t_p=8/20\mu s$ )
- ✧ Protects one bi-directional I/O line
- ✧ Low clamping voltage
- ✧ Working voltage:3.3V
- ✧ Low leakage current
- ✧ RoHS compliant
- ✧ Compliant to Halogen-free

### MAIN APPLICATIONS

- ✧ Cell phone handsets and accessories
- ✧ Microprocessor based equipment
- ✧ Personal digital assistants (PDA's)
- ✧ Notebooks, desktops, and servers
- ✧ Portable instrumentation
- ✧ Peripherals
- ✧ USB interface

### PROTECTION SOLUTION TO MEET

- ✧ IEC61000-4-2 (ESD)  $\pm 30kV$  (air),  $\pm 30kV$  (contact)
- ✧ IEC61000-4-4 (EFT) 40A (5/50ns)
- ✧ IEC61000-4-5 (Lightning) 20A (8/20 $\mu s$ )

### MECHANICAL CHARACTERISTICS

- ✧ SOD-323 package
- ✧ Molding compound flammability rating: UL 94V-0
- ✧ Lead finish: lead free
- ✧ Marking code: CA1



SOD-323

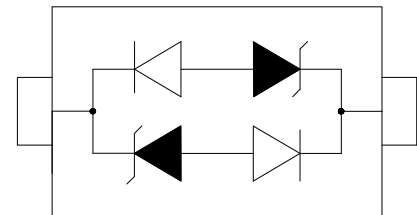

Pin Configuration

### ABSOLUTE MAXIMUM RATINGS (T<sub>A</sub>=25°C, RH=45%-75%, unless otherwise noted)

Parameter	Symbol	Value	Unit
Peak pulse power dissipation on 8/20μs waveform	P <sub>PP</sub>	350	W
ESD per IEC 61000-4-2 (Air) ESD per IEC 61000-4-2 (Contact)	V <sub>ESD</sub>	+/- 30 +/- 30	kV
Lead soldering temperature	T <sub>L</sub>	260 (10 sec.)	°C
Operating junction temperature range	T <sub>J</sub>	-55 to +125	°C
Storage temperature range	T <sub>STG</sub>	-55 to +150	°C

### ELECTRICAL CHARACTERISTICS (T<sub>A</sub>=25°C)

Parameter	Symbol	Conditions	Min	Typ	Max	Unit
Reverse working voltage	V <sub>RWM</sub>				3.3	V
Reverse breakdown voltage	V <sub>BR</sub>	I <sub>T</sub> =1mA	3.6			V
Reverse leakage current	I <sub>R</sub>	V <sub>RWM</sub> =3.3V			0.1	μA
Clamping voltage	V <sub>C</sub>	I <sub>PP</sub> =1A, t <sub>P</sub> =8/20μs			6.5	V
		I <sub>PP</sub> =10A, t <sub>P</sub> =8/20μs			12	V
		I <sub>PP</sub> =20A, t <sub>P</sub> =8/20μs			17.5	V
Junction capacitance	C <sub>J</sub>	V <sub>RWM</sub> =0V, f=1MHz		1.0	1.5	pF

**RATINGS AND V-I CHARACTERISTICS CURVES** ( $T_A=25^\circ\text{C}$ , unless otherwise noted)

**FIG.1: V- I curve characteristics (Bi-directional)**

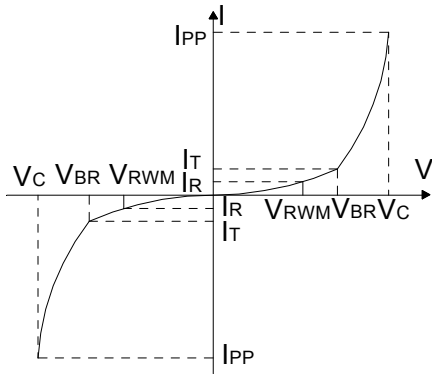

**FIG.2: Pulse waveform (8/20 $\mu\text{s}$ )**

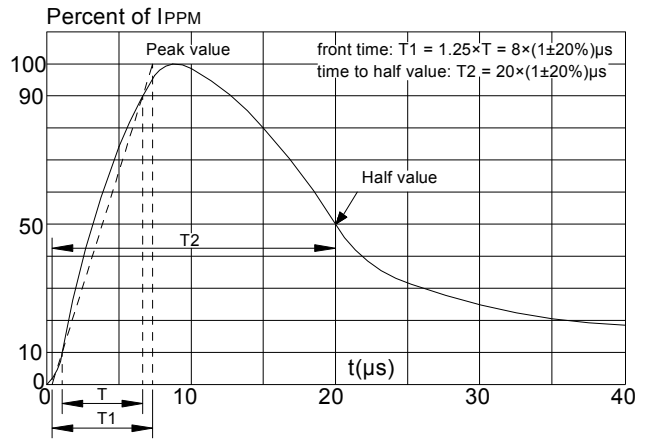

**FIG.3: Pulse derating curve**

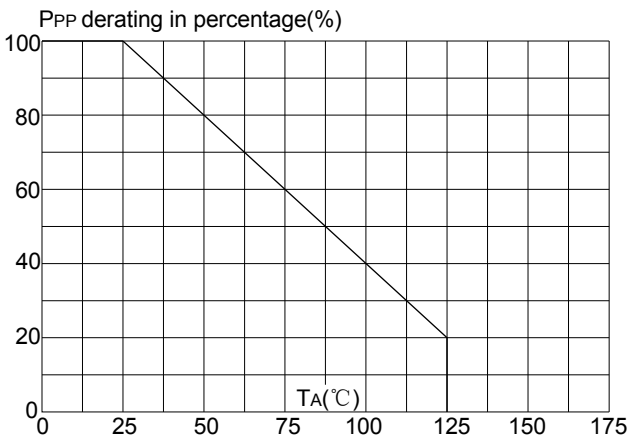

**FIG.4: ESD clamping (30kV contact)**

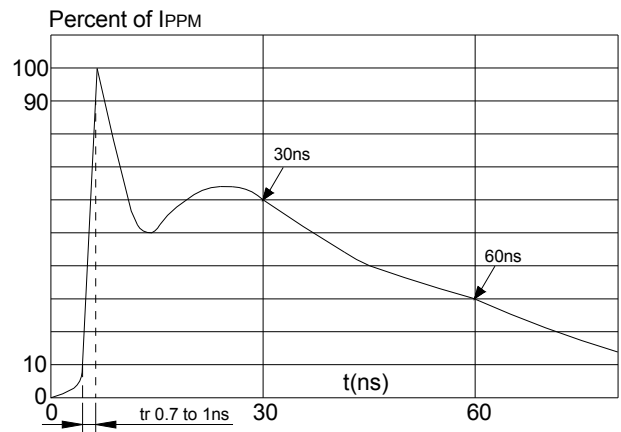

### PACKAGE MECHANICAL DATA

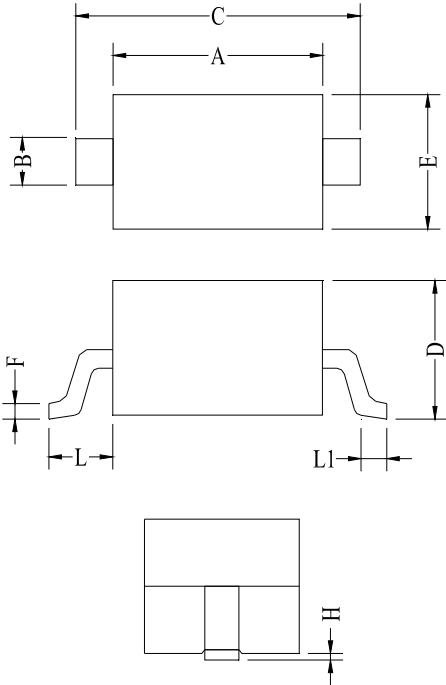

Symbol	Millimeters			Inches		
	Min	Typ	Max	Min	Typ	Max
A	1.600	1.700	1.800	0.063	0.067	0.071
B	0.250	0.320	0.400	0.010	0.013	0.016
C	2.300	2.600	2.800	0.091	0.102	0.110
D	0.800	0.950	1.100	0.031	0.037	0.043
E	1.200	1.300	1.400	0.047	0.051	0.055
F	0.080	0.130	0.180	0.003	0.005	0.007
L	0.475REF			0.019REF		
L1	0.250	0.330	0.400	0.010	0.013	0.016
H	0.000	0.060	0.140	0.000	0.002	0.006

### SUGGESTED LAND PATTERN

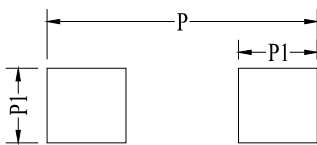

**Land Pattern**

Symbol	Millimeters			Inches		
	Min	Typ	Max	Min	Typ	Max
P	3.000			0.118		
P1	0.800			0.031		