

Features

- For surface mounted applications
- Low-profile package
- Ideal for automated placement
- Low incremental surge resistance, excellent clamping capability
- Compliant to Halogen-free
- Suffix "-Q1" for AEC-Q101

Mechanical Data

- Package: TO-263AB/D2PAK
- Molding compound meets UL 94 V-0 flammability rating, RoHS-compliant
- Terminals: Matte tin plated leads, solderable per J-STD-002 and JESD 22-B102

Package outline

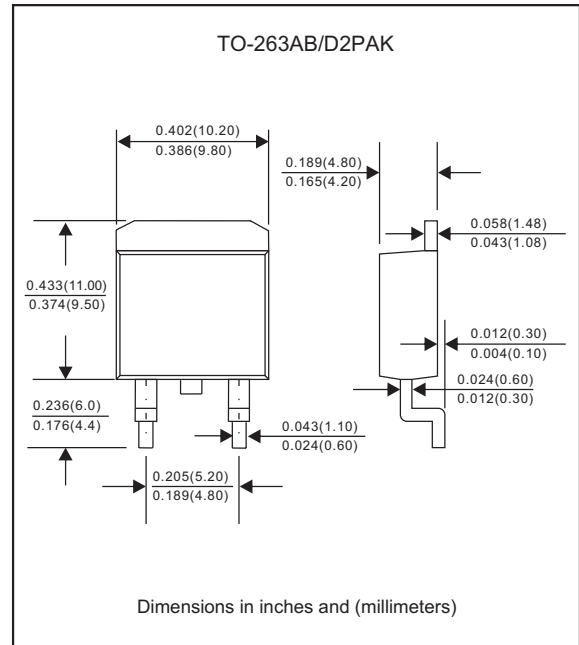

Absolute Maximum Ratings (Ta = 25°C unless otherwise specified)

Parameter	Symbol	Value	Unit
Peak pulse power dissipation with 10/1000us waveform ⁽¹⁾⁽²⁾ (fig.1)	P _{PPM}	5000	W
Power dissipation on infinite heatsink at T _L = 75°C	P _D	6.5	W
Peak pulse current with 10/1000us waveform ⁽¹⁾	I _{PPM}	See next table	A
Electrostatic Discharge	IEC61000-4-2 air discharge	± 30	kV
		IEC61000-4-2 contact discharge	± 30
Thermal resistance Junction to case ⁽³⁾	R _{thJC}	0.24	°C/W
Operating junction temperature range	T _{STG}	-65 to +175	°C
Operating junction and storage temperature range	T _J	-55 to +175	°C

Notes:

⁽¹⁾ Non-repetitive current pulse, per Fig. 3 and derated above T_A = 25°C per Fig.2.

⁽²⁾ Mounted on 0.6 x 0.6" (16.0 x 16.0 mm) copper pads to each terminal

⁽³⁾ Mounted on minimum recommended pad layout

Electrical Characteristics (T=25°C, RH=45%-75%, unless otherwise noted)

Device Type	Reverse Stand-off Voltage	Breakdown Voltage VBR @ IT		Test Current	Max. Clamping Voltage @ IPP	Max. Pda Pulse Current	Max. Reverse Leakage @ VRWM	Marking code
		Min.(V)	Max.(V)					
BI-POLAR	VRWM(V)	Min.(V)	Max.(V)	IT(mA)	VC MAX.(V)	IPP(A)	IR(uA)	
LDP5S24CA-Q1	24.00	26.70	29.50	1	38.9	129.0	5	LDP5S24CA
LDP5S26CA-Q1	26.00	28.90	31.90	1	42.1	119.0	5	LDP5S26CA
LDP5S28CA-Q1	28.00	31.10	34.40	1	45.4	110.0	5	LDP5S28CA
LDP5S30CA-Q1	30.00	33.30	36.80	1	48.4	103.0	5	LDP5S30CA
LDP5S33CA-Q1	33.00	36.70	40.60	1	53.3	93.9	5	LDP5S33CA
LDP5S36CA-Q1	36.00	40.00	44.20	1	58.1	86.1	5	LDP5S36CA
LDP5S40CA-Q1	40.00	44.40	49.10	1	64.5	77.6	5	LDP5S40CA
LDP5S43CA-Q1	43.00	47.80	52.80	1	69.4	72.1	5	LDP5S43CA
LDP5S45CA-Q1	45.00	50.00	55.30	1	72.7	68.8	5	LDP5S45CA
LDP5S48CA-Q1	48.00	53.30	58.90	1	77.4	64.7	5	LDP5S48CA
LDP5S51CA-Q1	51.00	56.70	62.70	1	82.4	60.7	5	LDP5S51CA
LDP5S54CA-Q1	54.00	60.00	66.30	1	87.1	57.5	5	LDP5S54CA
LDP5S58CA-Q1	58.00	64.40	71.20	1	93.6	53.5	5	LDP5S58CA
LDP5S60CA-Q1	60.00	66.70	73.70	1	96.8	51.7	5	LDP5S60CA
LDP5S64CA-Q1	64.00	71.10	78.60	1	103.0	48.6	5	LDP5S64CA
LDP5S70CA-Q1	70.00	77.80	86.00	1	113.0	44.3	5	LDP5S70CA
LDP5S75CA-Q1	75.00	83.30	92.10	1	121.0	41.4	5	LDP5S75CA
LDP5S78CA-Q1	78.00	86.70	95.80	1	126.0	39.7	5	LDP5S78CA
LDP5S80CA-Q1	80.00	89.40	98.80	1	130.0	38.5	5	LDP5S80CA
LDP5S85CA-Q1	85.00	94.40	104.00	1	137.0	36.5	5	LDP5S85CA

Notes:

- (1) Pulse Test: $t_p \leq 50\text{ms}$.
- (2) Surge current waveform per Fig. 3 and derated per Fig.2.

Ratings and Characteristics Curves (Ta = 25°C unless otherwise noted)

Fig. 1 - Power Derating Curve

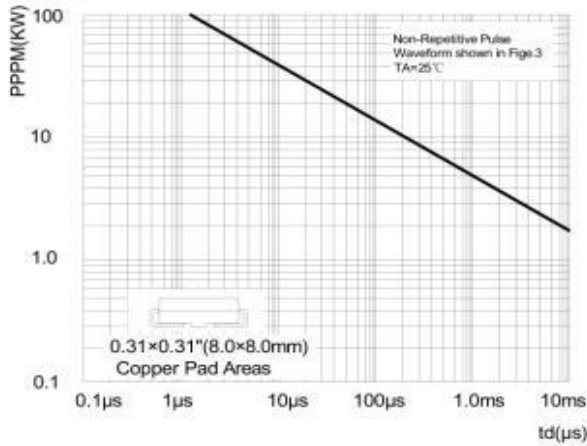

Fig. 2 - Pulse Power or Current vs. Initial Junction Temperature

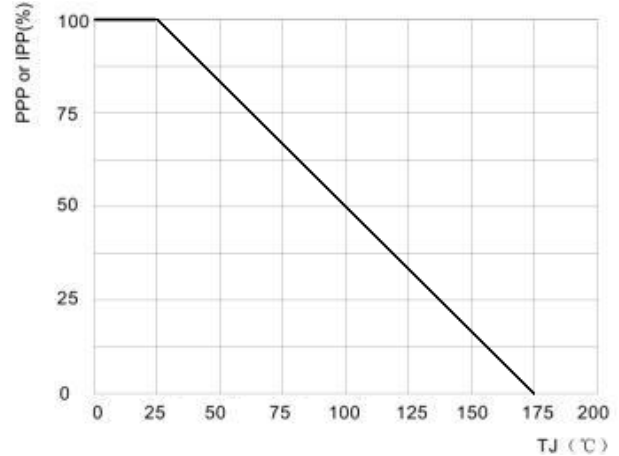

Fig. 3 - Pulse Waveform

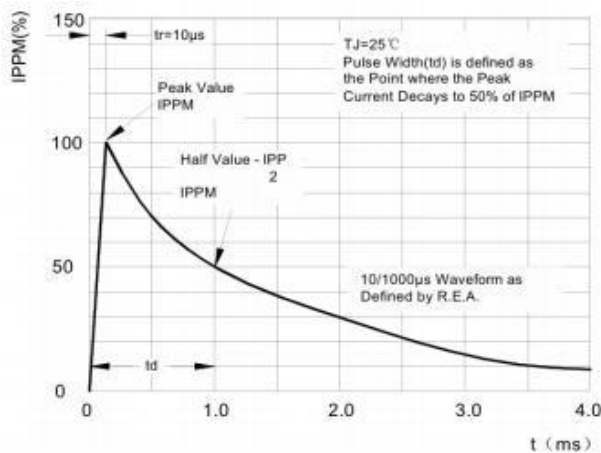

Fig. 4 - Typical Transient Thermal Impedance

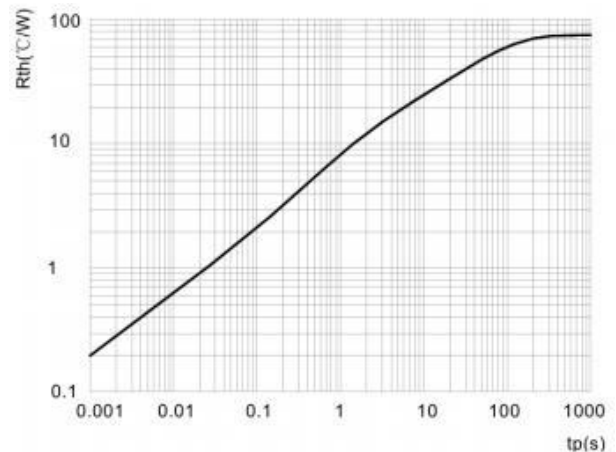

Fig. 5 - Maximum Non-Repetitive Surge Current

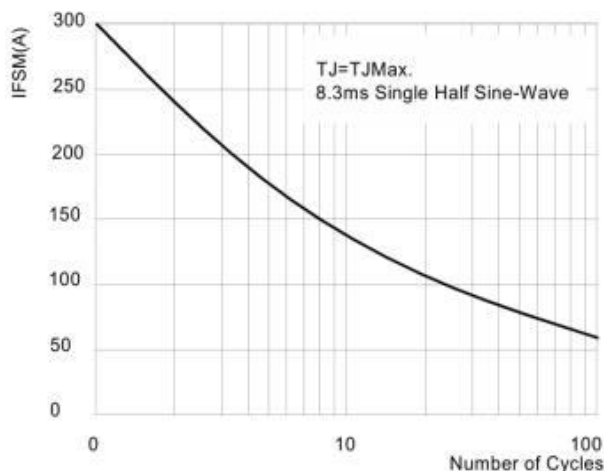
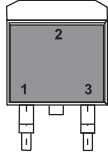
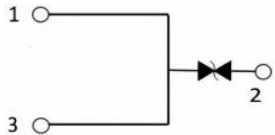

Fig. 6 - Steady State Power Dissipation



Pinning information

Pin	Simplified outline	Symbol
Pin1 anode Pin2 cathode Pin3 anode		

Marking

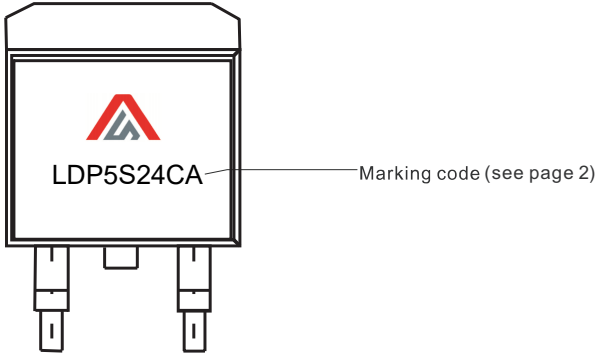
Type number	Example
Bi-Directional	

Suggested solder pad layout

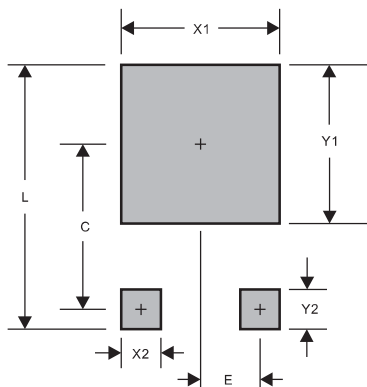

PACKAGE	D2PAK
C	0.374(9.50)
E	0.098(2.50)
L	0.665(16.90)
X1	0.425(10.80)
X2	0.071(1.80)
Y1	0.449(11.40)
Y2	0.138(3.50)

Dimensions in inches and (millimeters)