

MBR30U150FCT

30A Ultra Low VF Trench MOS Schottky Rectifiers-150V

Features

- Extremely LOW VF
- Trench MOS schottky technology
- Low power loss/high efficiency
- High frequency operation
- High forward surge capability
- Suffix "-H" indicates Halogen-free parts,ex.MBR30U150FCT-H

Mechanical data

- Epoxy:UL 94-V0 rated flame retardant
- Case:JEDEC ITO-220AB molded plastic body over passivated chip
- Lead :Axialleads,solderable per MIL-STD -202, Method 208 guranteed
- Polarity :Color band denotes cathode end
- Mounting Position :Any

Package outline

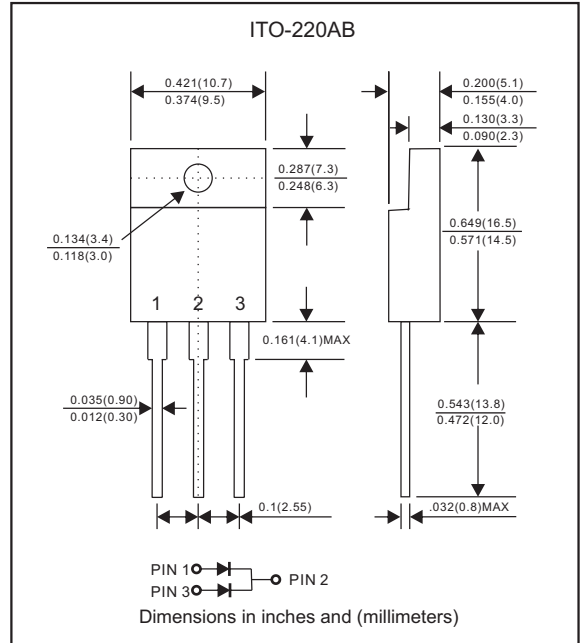

Maximum ratings and Electrical Characteristics (AT $T_A=25^{\circ}\text{C}$ unless otherwise noted)

PARAMETER	CONDITIONS	Symbol	MIN.	TYP.	MAX.	UNIT
Forward rectified current	See Fig.1	I_o			30.0	A
Forward surge current	8.3ms single half sine-wave (JEDEC methode)	I_{FSM}			200	A
Reverse current	$V_R = V_{RRM}$ $T_J = 25^{\circ}\text{C}$	I_R			0.1	mA
	$V_R = V_{RRM}$ $T_J = 125^{\circ}\text{C}$				20	
Thermal resistance	Junction to case	R_{BJC}		4.0		$^{\circ}\text{C}/\text{W}$
Storage temperature		T_{STG}	- 55		+150	$^{\circ}\text{C}$

SYMBOLS	V_{RRM}^{*1} (V)	V_{RMS}^{*2} (V)	V_R^{*3} (V)	V_F^{*4} (V)	Operating temperature T_J ($^{\circ}\text{C}$)
MBR30U150FCT	150	105	150	0.87	-55 to +150

*1 Repetitive peak reverse voltage

*2 RMS voltage

*3 Continuous reverse voltage

*4 Maximum forward voltage

IF = 15.0A

Rating and characteristic curves

FIG. 1- DERATING CURVE OUTPUT RECTIFIED CURRENT

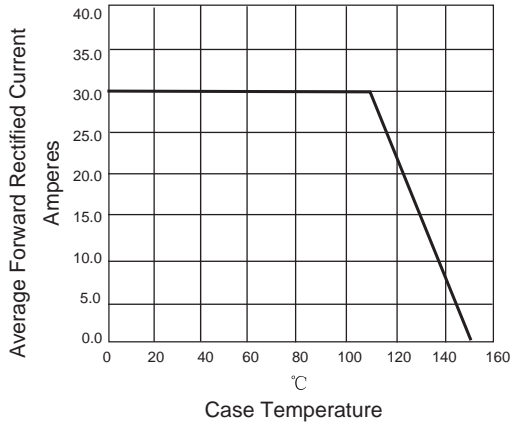

FIG. 2-MAXIMUM NON-REPETITIVE PEAK FORWARD SURGE CURRENT PERLEG

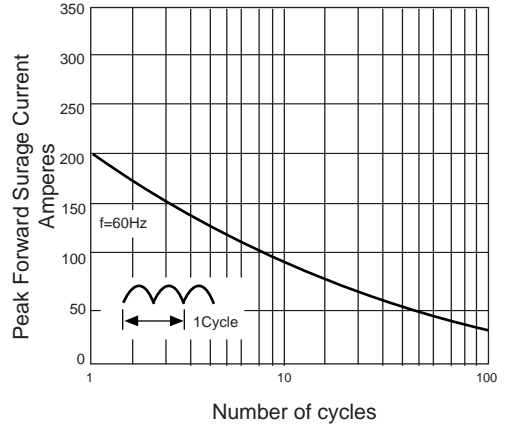

FIG. 3-TYPICAL FORWARD VOLTAGE CHARACTERISTICS

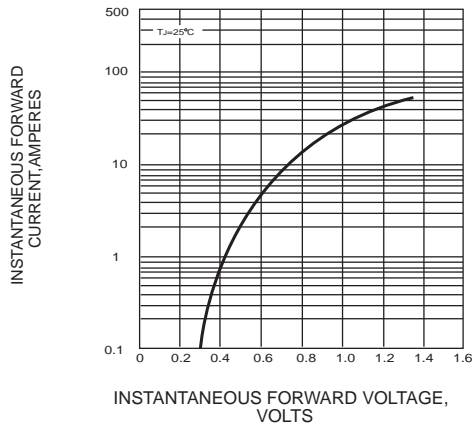
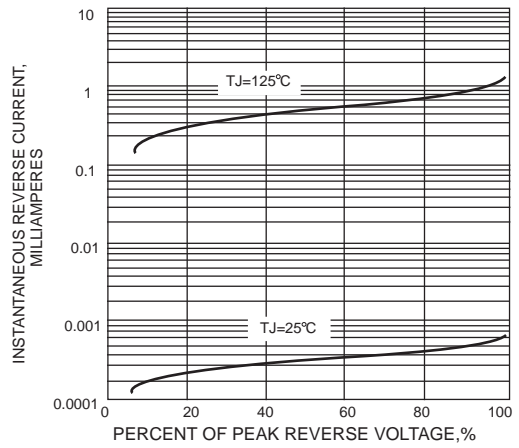

FIG. 4-TYPICAL REVERSE LEAKAGE CHARACTERISTICS



MBR30U150FCT

30A Ultra Low VF Trench MOS Schottky
Rectifiers-150V

Pinning information

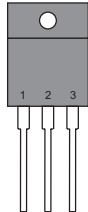
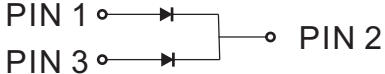
Pin	Simplified outline	Symbol
Pin1 anode Pin2 cathode Pin3 anode		

Marking

Type number	Marking code
MBR30U150FCT	MBR30U150FCT