

Features

- Lead-free parts for green partner, exceeds environmental standards of MIL-STD-19500 /228
- Compliant to Halogen-free
- Suffix "-Q1" for AEC-Q101

Mechanical data

- Epoxy:UL94-V0 rated flame retardant
- Case : Molded plastic, SOT-23
- Terminals : Solder plated, solderable per MIL-STD-750, Method 2026
- Mounting Position : Any

Package outline

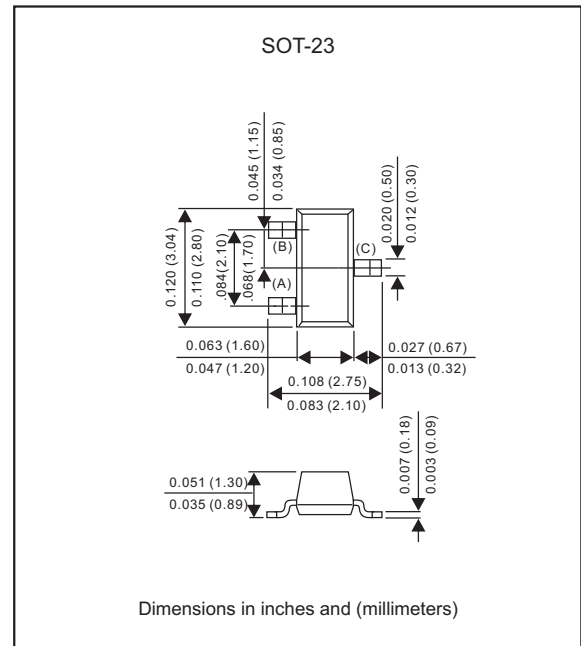

Maximum ratings (AT $T_A=25^{\circ}\text{C}$ unless otherwise noted)

PARAMETER	CONDITIONS	Symbol	MMBTA05-Q1	MMBTA06-Q1	UNIT
Collector-Base voltage		V_{CBO}	60	80	Vdc
Collector-Emitter voltage		V_{CEO}	60	80	Vdc
Emitter-Base voltage		V_{EBO}	4.0		Vdc
Collector current		I_C	500		mAdc

Thermal Characteristics

Characteristics	CONDITIONS	Symbol	Max	UNIT
Total device dissipation FR-5 board (1)	$T_A = 25^{\circ}\text{C}$	P_D	225	mW
	Derate above 25°C	P_D	1.8	mW/ $^{\circ}\text{C}$
Thermal resistance	Junction to ambient	$R_{\theta JA}$	556	$^{\circ}\text{C}/\text{W}$
Total device dissipation alumina substrate(2)	$T_A = 25^{\circ}\text{C}$	P_D	300	mW
	Derate above 25°C	P_D	2.4	mW/ $^{\circ}\text{C}$
Thermal resistance	Junction to ambient	$R_{\theta JA}$	416	$^{\circ}\text{C}/\text{W}$
Operating temperature		T_J	-55 ~ +150	$^{\circ}\text{C}$
Storage temperature		T_{STG}	-65 ~ +150	

- 1.FR-5 = 1.0 X 0.75 X 0.062 in.
- 2.Alumina = 0.4 X 0.3 X 0.024 in. 99.5% alumina.
3. Pulse test: pulse width $\geq 300\mu\text{s}$, duty cycle $\leq 2.0\%$
4. fr is defined as the frequency at which hfe extrapolates to unity.

Characteristics (AT $T_A=25^{\circ}\text{C}$ unless otherwise noted)

Off Characteristics

PARAMETER	CONDITIONS	Symbol	Types	Min.	Max.	UNIT
Collector-Base breakdown voltage	$I_c = 100\mu\text{Adc}, I_E = 0$	$V_{(BR)CBO}$	MMBTA05-Q1	60	-	Vdc
			MMBTA06-Q1	80	-	
Collector-Emitter breakdown voltage(3)	$I_c = 1.0\text{mAdc}, I_B = 0$	$V_{(BR)CEO}$	MMBTA05-Q1	60	-	Vdc
			MMBTA06-Q1	80	-	
Emitter-Base breakdown voltage	$I_E = 100\mu\text{Adc}, I_C = 0$	$V_{(BR)EBO}$		4.0	-	Vdc
Collector Cutoff Current	$V_{CE}=60\text{Vdc}, I_B=0$	I_{CES}		-	0.1	μAdc
Collector cutoff current	$V_{CB} = 60\text{Vdc}, I_E = 0$ $V_{CB} = 80\text{Vdc}, I_E = 0$	I_{CBO}	MMBTA05-Q1	-	0.1	μAdc
			MMBTA06-Q1	-	0.1	

On Characteristics

PARAMETER	CONDITIONS	Symbol	Min.	Max.	UNIT
DCcurrent gain	$I_c = 10\text{mAdc}, V_{CE} = 1.0\text{Vdc}$	h_{FE}	100	-	-
	$I_c = 100\text{mAdc}, V_{CE} = 1.0\text{Vdc}$		100	-	
Collector-Emitter saturation voltage	$I_c = 100\text{mAdc}, I_B = 10\text{mAdc}$	$V_{CE(sat)}$	-	0.25	Vdc
Base-Emitter saturation voltage	$I_c = 100\text{mAdc}, V_{CE} = 1.0\text{Vdc}$	$V_{BE(on)}$	-	1.2	Vdc

Small Signal Characteristics

PARAMETER	CONDITIONS	Symbol	Min.	Max.	UNIT
Current Gain Bandwidth Product (4)	$I_c = 10\text{mA}, V_{CE} = 2.0\text{V}, f=100\text{MHz}$	f_T	100	-	MHz

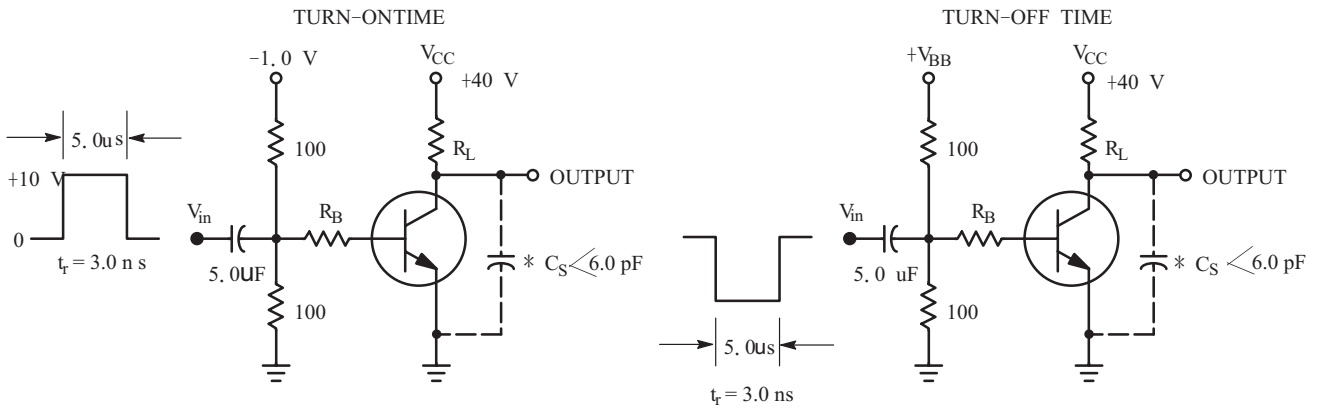

*Total Shunt Capacitance of Test Jig and Connectors
For PNP Test Circuits, Reverse All Voltage Polarities

FIG1. Switching Time Test Circuits

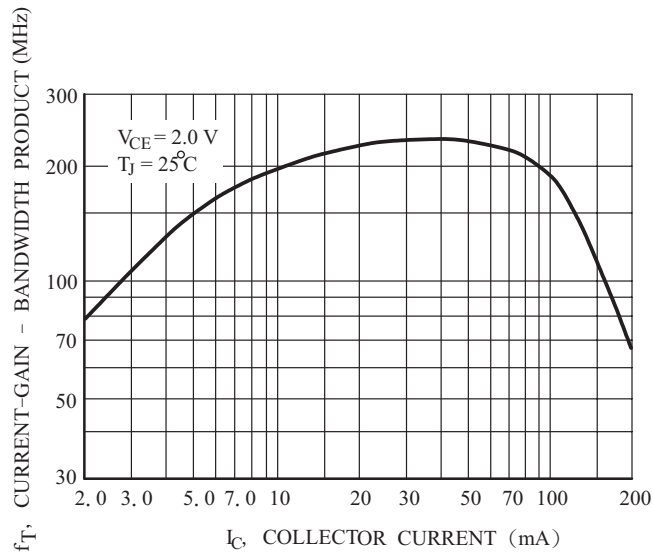

FIG2. Current-Gain Bandwidth Product

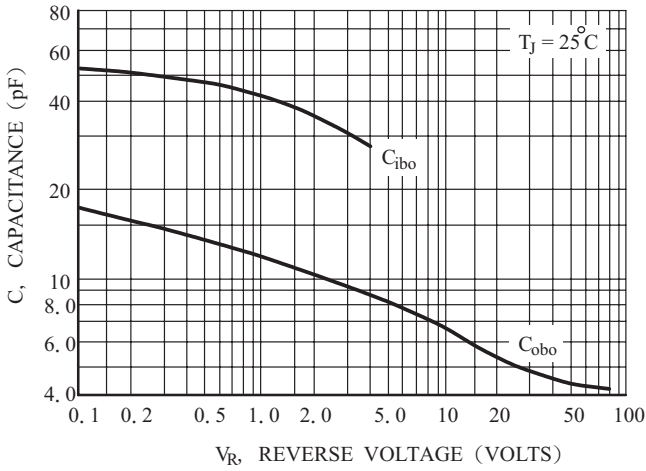

FIG3. Capacitance

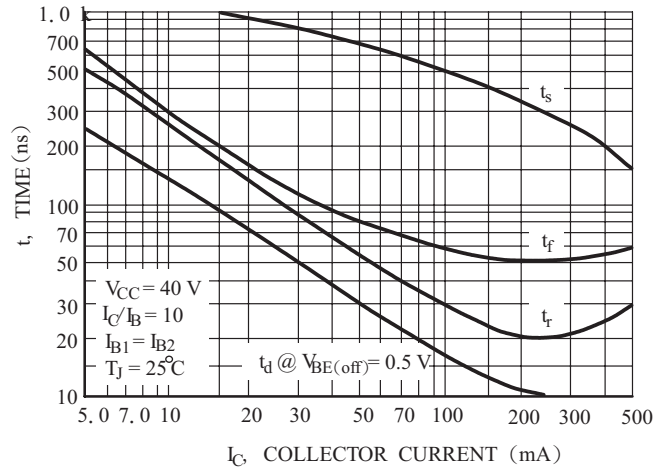

FIG4. Switching Time

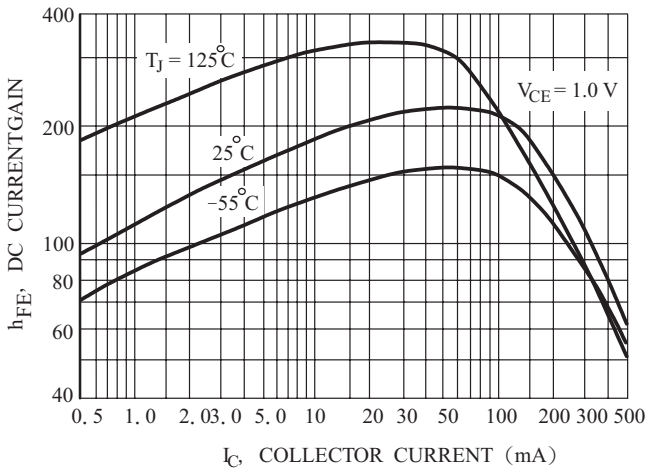

FIG5. DC Current Gain

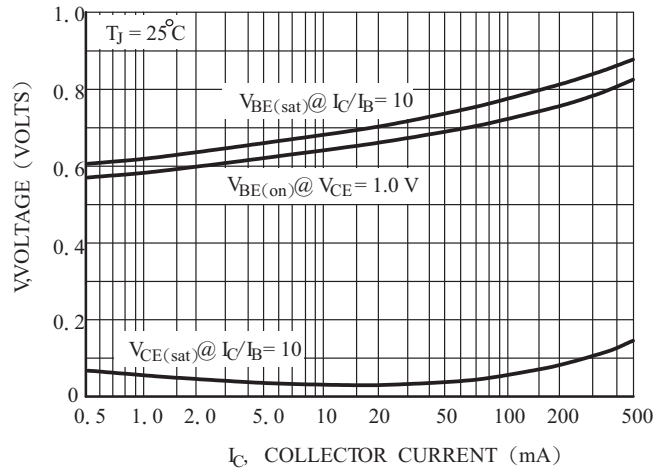

FIG6. "ON" Voltages

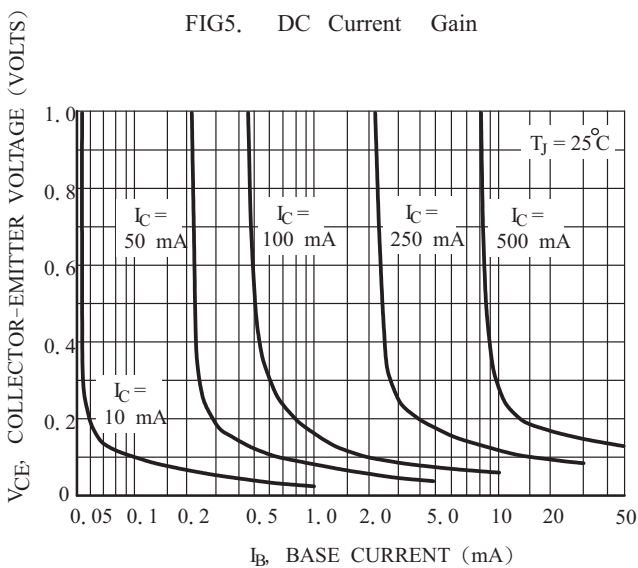

FIG7. Collector Saturation Region

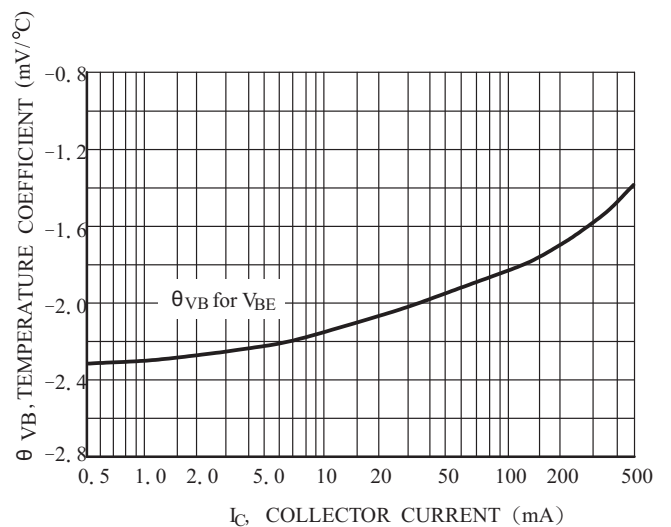
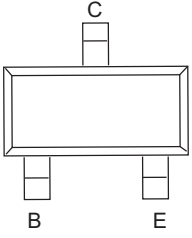
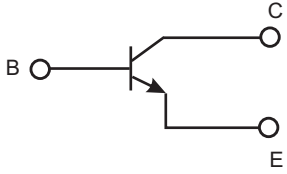

FIG8. Base-Emitter Temperature Coefficient

Pinning information

Pin	Simplified outline	Symbol
PinB Base PinC Collector PinE Emitter		

Marking

Type number	Marking code
MMBTA05-Q1	1H
MMBTA06-Q1	1GM

Suggested solder pad layout

SOT-23

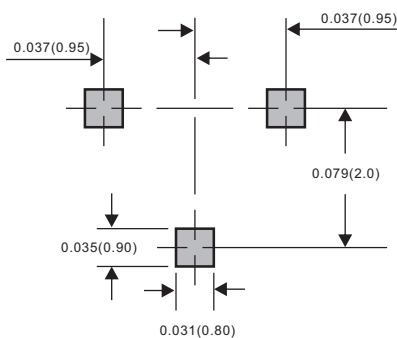

Dimensions in inches and (millimeters)