

Features

- Epoxy meets UL-94 V-0 flammability rating
- Surface mount package ideally Suited for Automatic Insertion
- Compliant to Halogen-free
- Suffix "-Q1" for AEC-Q101

Mechanical Data

- **Package:** SOT-363
- **Terminals:** Tin plated leads, solderable per J-STD-002 and JESD22-B102
- **Marking:** K2X

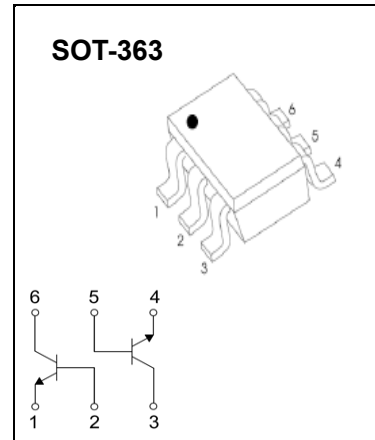

Maximum Ratings (Ta=25°C Unless otherwise specified)

Symbol	Parameter	Value	Units
V _{CB0}	Collector-Base Voltage	60	V
V _{CEO}	Collector-Emitter Voltage	40	V
V _{EBO}	Emitter-Base Voltage	6	V
I _C	Collector Current -Continuous	0.6	A
P _C	Collector Power Dissipation	0.2	W
T _J , T _{stg}	Operation Junction and Storage Temperature Range	-55 ~ +150	°C

Electrical Characteristics (Ta=25°C unless otherwise specified)

Parameter	Symbol	Test conditions	Min	Max	Unit
Collector-base breakdown voltage	V _{(BR)CBO}	I _C = 100 μA, I _E =0	60		V
Collector-emitter breakdown voltage	V _{(BR)CEO}	I _C = 1mA, I _B =0	40		V
Emitter-base breakdown voltage	V _{(BR)EBO}	I _E = 100 μA, I _C =0	6		V
Collector cut-off current	I _{CBO}	V _{CB} = 50 V, I _E =0		0.1	μA
Collector cut-off current	I _{CEO}	V _{CE} = 35 V, I _B =0		0.5	μA
Emitter cut-off current	I _{EBO}	V _{EB} = 5V, I _C =0		0.1	μA
DC current gain	h _{FE(1)}	V _{CE} = 1V, I _C = 0.1mA	20		
	h _{FE(2)}	V _{CE} = 1V, I _C = 1mA	40		
	h _{FE(3)}	V _{CE} = 1V, I _C = 10mA	80		
	h _{FE(4)}	V _{CE} = 1V, I _C = 150mA	100	300	
	h _{FE(5)}	V _{CE} = 2V, I _C = 500mA	40		
Collector-emitter saturation voltage	V _{CE(sat)1}	I _C =150 mA, I _B = 15mA		0.4	V
	V _{CE(sat)2}	I _C =500 mA, I _B = 50mA		0.75	V
Base-emitter saturation voltage	V _{BE(sat)1}	I _C = 150 mA, I _B = 15mA		0.95	V
	V _{BE(sat)2}	I _C = 500 mA, I _B = 50mA		1.2	V
Transition frequency	f _T	V _{CE} = 10V, I _C = 20mA, f=100MHz	250		MHz
Delay time	t _d	V _{CC} =30V,		15	nS
Rise time	t _r	V _{BE} =2V, I _C =150mA, I _{B1} =15mA		20	nS
Storage time	t _s	V _{CC} =30V, I _C =150mA, I _{B1} =-I _{B2} =15mA		225	nS
Fall time	t _f			30	nS

Characteristics (Typical)

Static Characteristic

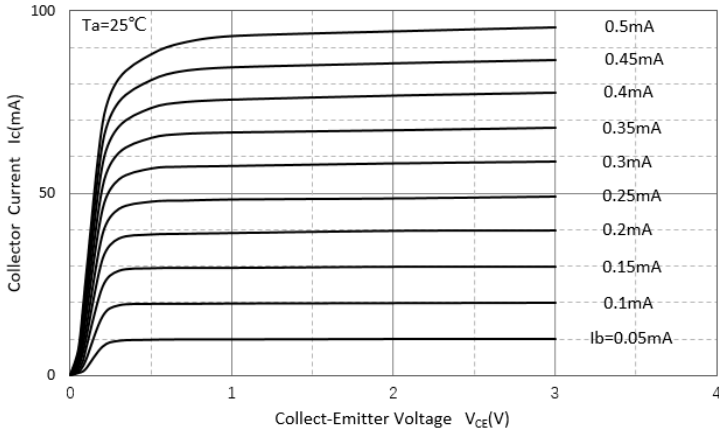

DC Current Gain

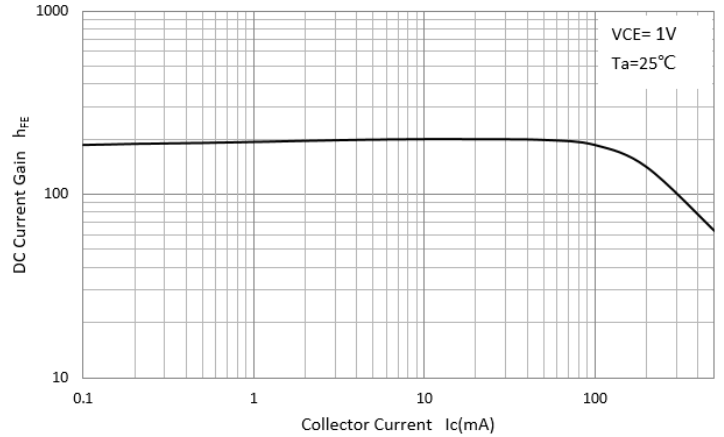

Collector-Emitter Saturation Voltage

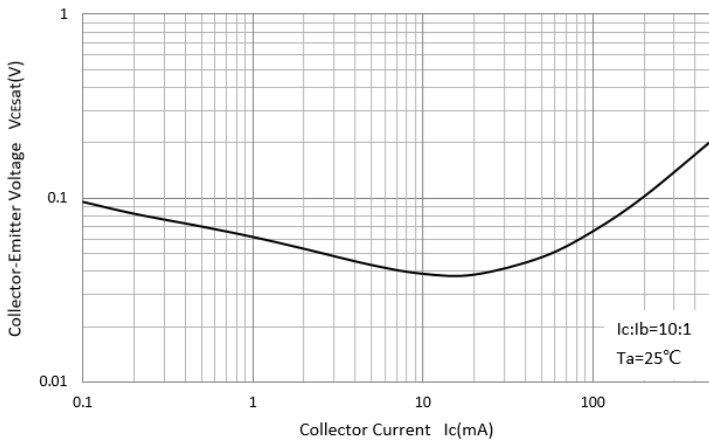

Base-Emitter Saturation Voltage

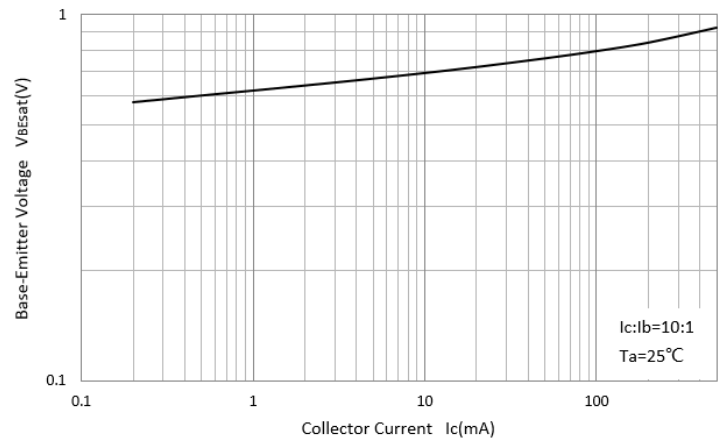

Base-Emitter On Voltage

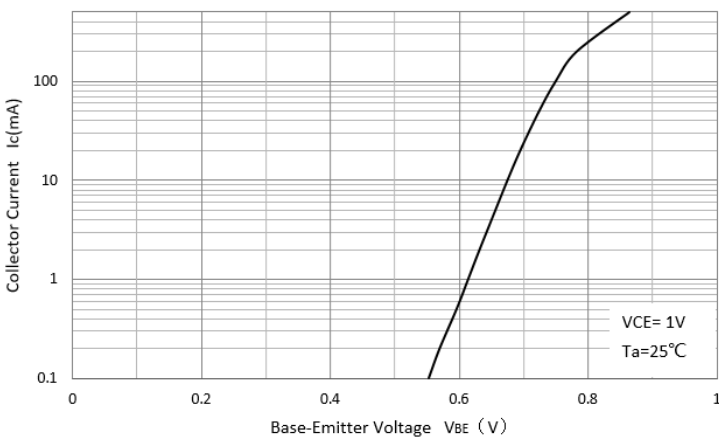

$C_{ob}/C_{ib}-V_{CB}/V_{EB}$

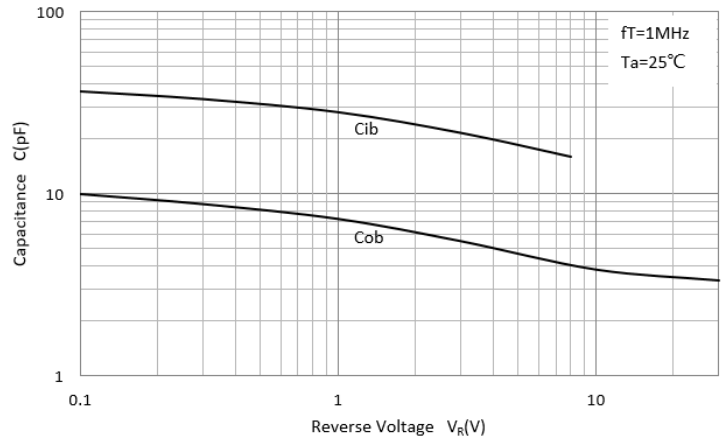

SOT-363 Package Outline Dimensions

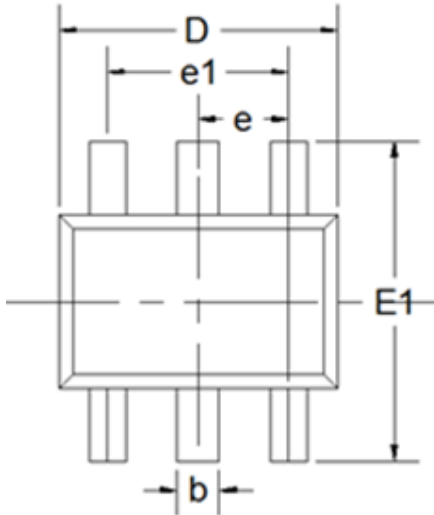

DIM	DIMENSIONS			
	INCHES		MM	
	MIN	MAX	MIN	MAX
A	0.035	0.043	0.9	1.1
A1	0	0.004	0	0.1
A2	0.035	0.039	0.9	1
b	0.006	0.014	0.15	0.35
c	0.002	0.01	0.05	0.25
D	0.071	0.087	1.8	2.2
E	0.045	0.053	1.15	1.35
E1	0.085	0.096	2.15	2.45
e	0.026Typ		0.65Typ	
e1	0.047	0.055	1.2	1.4
L	0.021Typ		0.525Typ	
L1	0.01	0.018	0.26	0.46
φ	0°	8°	0°	8°

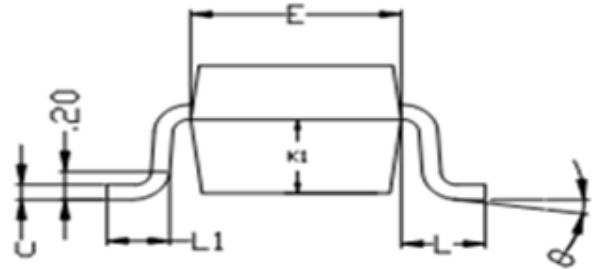
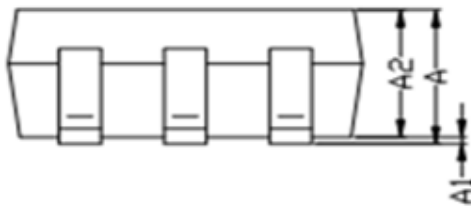

SOT-363 Soldering Footprint

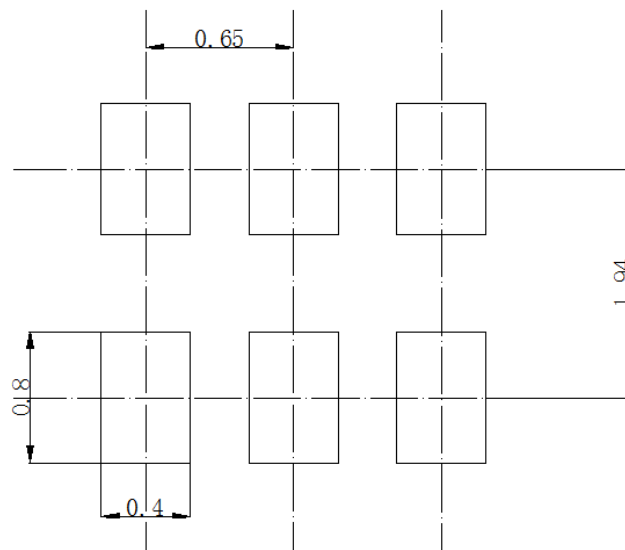

Unit: mm