

Features

- Dual rectifier construction, positive centetap, offer 5.0A Half wave and 10.0A full wave rectification.
- High surge current capability.
- Super fast recovery time for switching mode application
- Low power loss.
- Glass passivated chip junctions.
- Lead-free parts meet environmental standards of MIL-STD-19500/228

Mechanical data

- Epoxy : UL94-V0 rated flame retardant
- Case : JEDEC ITO-220AB molded plastic body over passivated chip
- Lead : Axial leads, solderable per MIL-STD-202, Method 208 guranteed
- Polarity: As marked
- Mounting Position : Any

Package outline

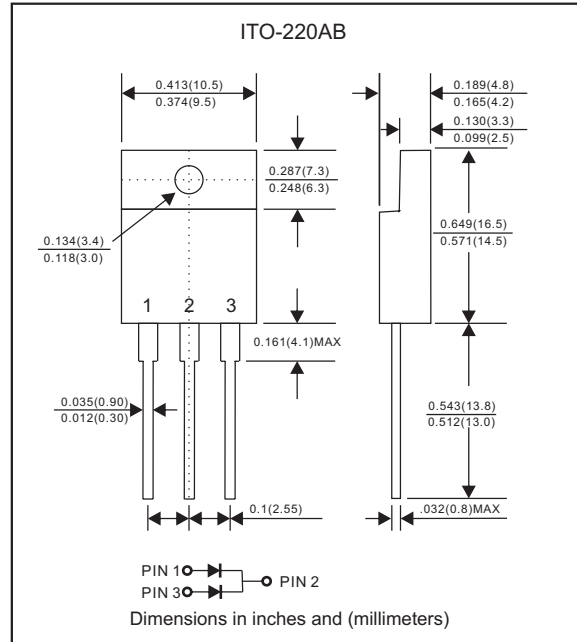

Maximum ratings (AT $T_A=25^{\circ}\text{C}$ unless otherwise noted)

PARAMETER	SYMBOLS	MUR1020FCT	MUR1040FCT	MUR1060FCT	UNIT
Maximum repetitive peak reverse voltage	V_{RRM}	200	400	600	V
Maximum RMS voltage	V_{RMS}	140	280	420	V
Maximum DC blocking voltage	V_{DC}	200	400	600	V
Maximum average forward rectified current	I_o	10			A
Peak forward surge current 8.3ms single half sine-wave(JEDEC method)	I_{FSM}	100			A
Operating junction temperature range	T_J	-55 to +150			$^{\circ}\text{C}$
Storage temperature range	T_{STG}	-65 to +175			$^{\circ}\text{C}$

Electrical Characteristics (AT $T_A=25^{\circ}\text{C}$ unless otherwise noted)

PARAMETER	SYMBOLS	MUR1020FCT	MUR1040FCT	MUR1060FCT	UNIT
Maximum forward voltage per leg at $I_F=5.0A$	V_F	0.98	1.30	1.70	V
Maximum reverse recovery time per leg (Note 1)	t_{rr}	25	50		ns
Maximum DC reverse current at $T_J=25^{\circ}\text{C}$ at rated DC blocking voltage per leg at $T_J=125^{\circ}\text{C}$	I_R	5.0 500			μA μA

Thermal Characteristics

PARAMETER	SYMBOLS	MUR1020FCT	MUR1040FCT	MUR1060FCT	UNIT
Typical thermal resistance junction to case per leg	$R_{\theta JC}$	2.5			$^{\circ}\text{C}/\text{W}$

Note 1: Reverse recovery time test condition, $I_F=0.5A$, $I_R=1.0A$, $I_{RR}=0.25A$

Rating and characteristic curves(MUR1020FCT THRU MUR1060FCT)

FIG.1-TYPICAL FORWARD CURRENT DERATING CURVE

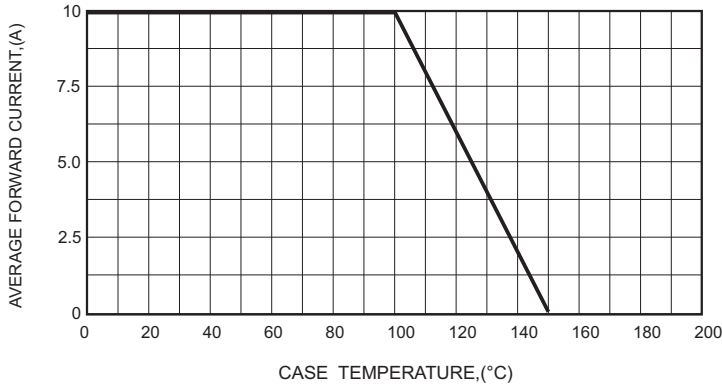

FIG.2-TYPICAL FORWARD CHARACTERISTICS

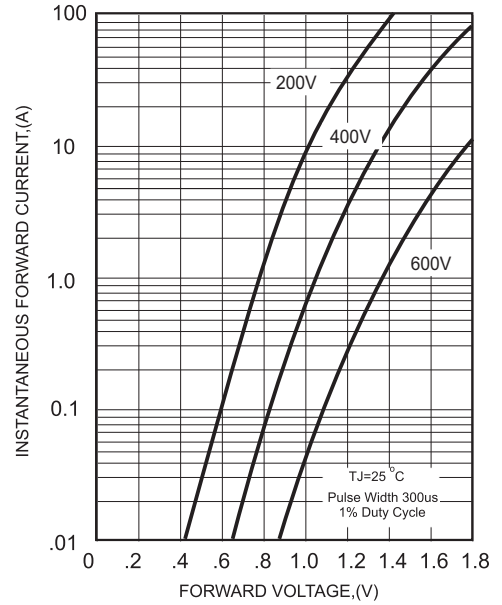

FIG.3-MAXIMUM NON-REPETITIVE FORWARD SURGE CURRENT

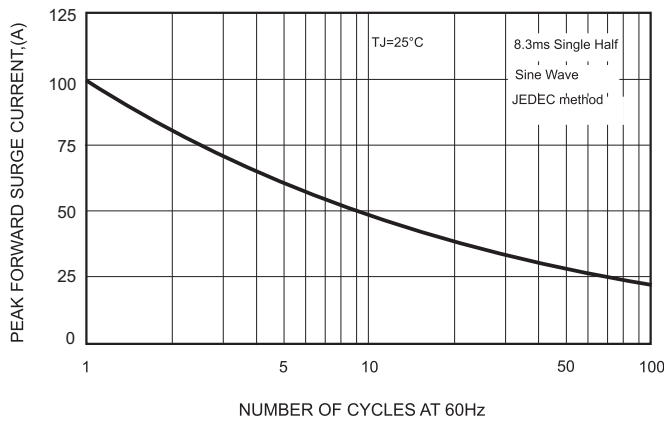

FIG.4 - TYPICAL REVERSE CHARACTERISTICS

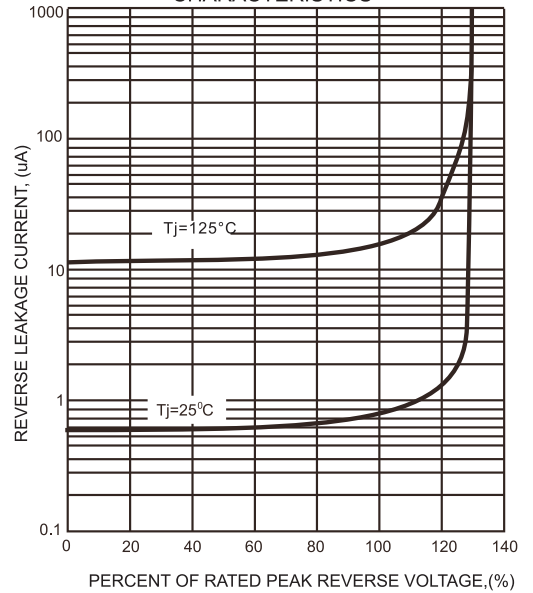
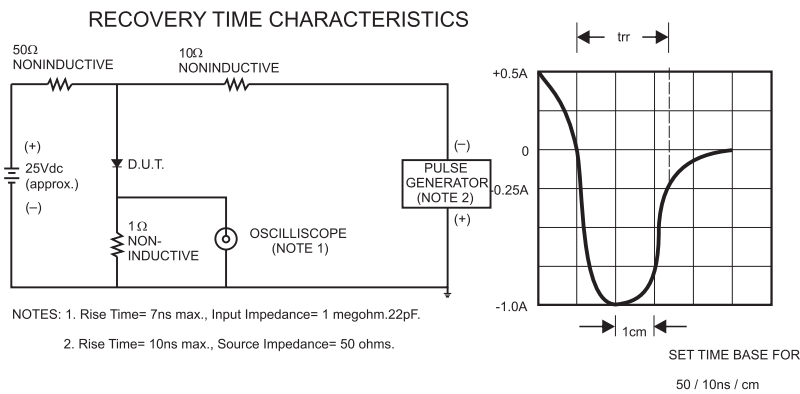

FIG.5- TEST CIRCUIT DIAGRAM AND REVERSE RECOVERY TIME CHARACTERISTICS



NOTES: 1. Rise Time= 7ns max., Input Impedance= 1 megohm, 22pF.
2. Rise Time= 10ns max., Source Impedance= 50 ohms.

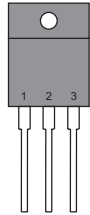
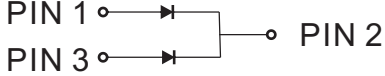

Pinning information

Pin	Simplified outline	Symbol
Pin1 anode Pin2 cathode Pin3 anode		

Marking

Type number	Marking code
MUR1020FCT	MUR1020FCT
MUR1040FCT	MUR1040FCT
MUR1060FCT	MUR1060FCT