

### Features

- ▶ The plastic package carries Underwriters Laboratory Flammability Classification 94V-0
- ▶ Low reverse leakage
- ▶ High forward surge current capability
- ▶ High temperature soldering guaranteed: 250°C/10 seconds at terminals
- ▶ Glass passivated chip junction
- ▶ Compliant to RoHS Directive 2011/65/EU
- ▶ Compliant to Halogen-free
- ▶ Suffix "-Q1" for AEC-Q101

### Mechanical data

- ▶ **Case:** TO-277B molded plastic body
- ▶ **Terminals:** Solder plated, solderable per MIL-STD-750, Method 2026
- ▶ **Polarity:** Polarity symbol marking on body
- ▶ **Mounting Position:** Any

### Package outline

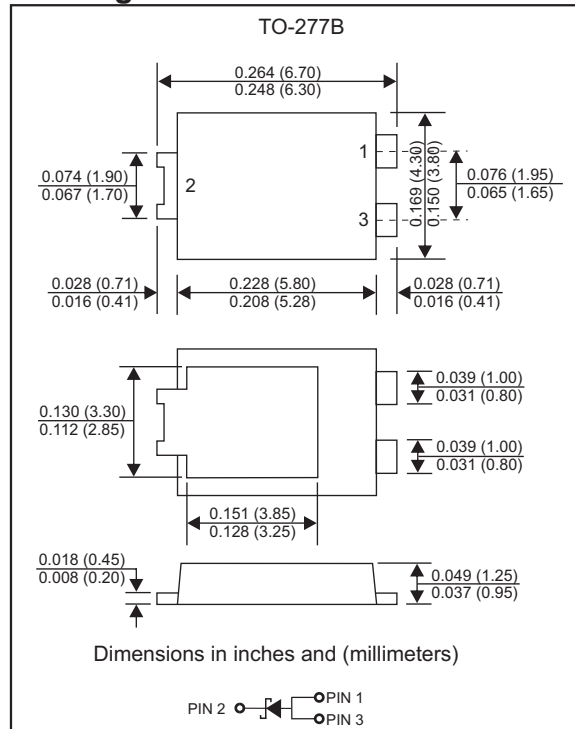

### Maximum ratings and Electrical Characteristics (AT $T_A=25^\circ\text{C}$ unless otherwise noted)

PARAMETER	CONDITIONS	Symbol	MIN.	TYP.	MAX.	UNIT
Forward rectified current	$T_L = 100^\circ\text{C}$	$I_O$			10.0	A
Forward surge current	8.3ms single half sine-wave (JEDEC methode)	$I_{FSM}$			200	A
Reverse current	$V_R = V_{RRM} \quad T_J = 25^\circ\text{C}$	$I_R$			5.0	$\mu\text{A}$
	$V_R = V_{RRM} \quad T_J = 125^\circ\text{C}$				500	
Thermal resistance	Junction to ambient	$R_{\theta JA}$		60		$^\circ\text{C}/\text{W}$
Diode junction capacitance	f=1MHz and applied 4V DC reverse voltage	$C_J$		80		pF
Storage temperature		$T_{STG}$	-55		+150	$^\circ\text{C}$

SYMBOLS	$V_{RRM}^{*1}$ (V)	$V_{RMS}^{*2}$ (V)	$V_R^{*3}$ (V)	$V_F^{*4}$ (V)	Operating temperature $T_J, (^\circ\text{C})$
S10A-T-Q1	50	35	50	1.10	-55 to +150
S10B-T-Q1	100	70	100		
S10D-T-Q1	200	140	200		
S10G-T-Q1	400	280	400		
S10J-T-Q1	600	420	600		
S10K-T-Q1	800	560	800		
S10M-T-Q1	1000	700	1000		

\*1 Repetitive peak reverse voltage

\*2 RMS voltage

\*3 Continuous reverse voltage

\*4 Maximum forward voltage@ $I_F=10.0\text{A}$

### Rating and characteristic curves

FIG. 1- DERATING CURVE OUTPUT RECTIFIED CURRENT

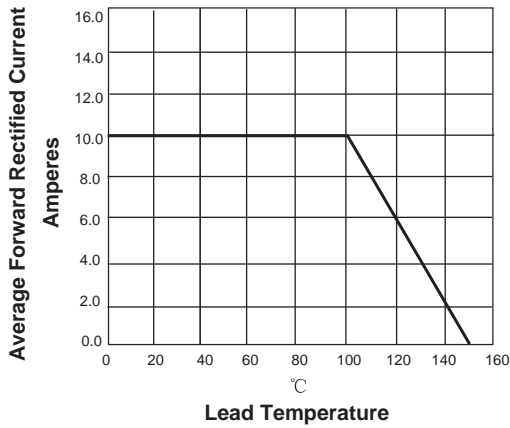

FIG. 2-MAXIMUM NON-REPETITIVE PEAK FORWARD SURGE CURRENT PER LEG

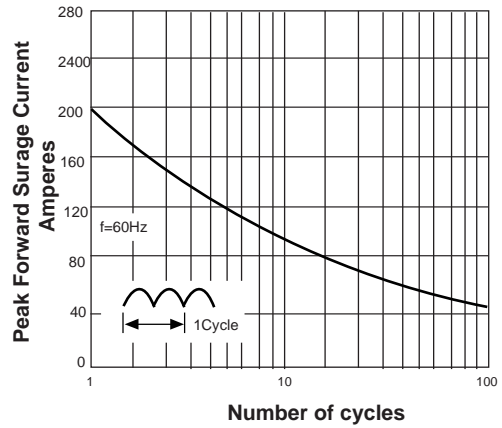

FIG. 3-TYPICAL FORWARD VOLTAGE CHARACTERISTICS

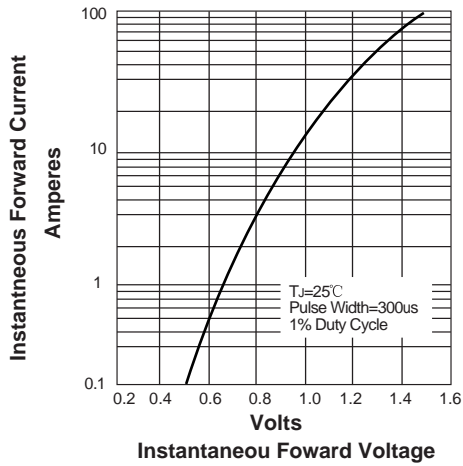
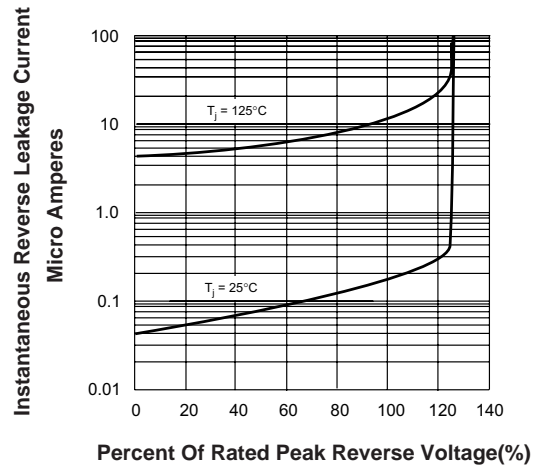

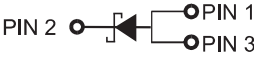

FIG. 4-TYPICAL REVERSE LEAKAGE CHARACTERISTICS



### Pinning information

Pin	Simplified outline	Symbol
Pin2 cathode Pin1 anode Pin3 anode		

### Marking

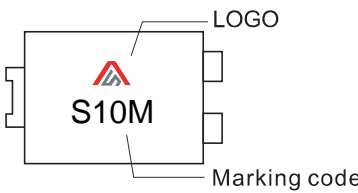
Type number	Marking code	Example
S10A-T-Q1	S10A	
S10B-T-Q1	S10B	
S10D-T-Q1	S10D	
S10G-T-Q1	S10G	
S10J-T-Q1	S10J	
S10K-T-Q1	S10K	
S10M-T-Q1	S10M	

### Suggested solder pad layout

TO-277B

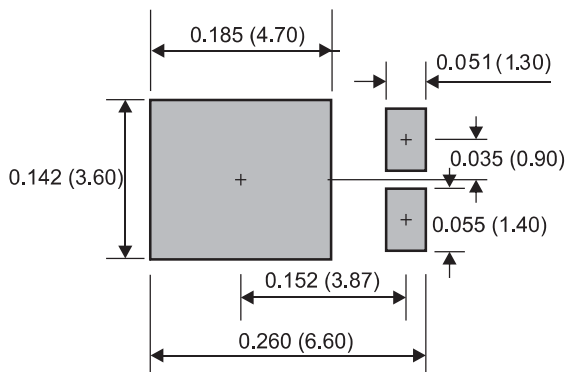

Dimensions in inches and (millimeters)