

### FEATURES

- ✧ 350 Watts peak pulse power per line ( $t_p=8/20\mu s$ )
- ✧ Protect for two I/O lines with bi-directional
- ✧ Low clamping voltage
- ✧ Working voltages: 5V
- ✧ Low leakage current
- ✧ ROHS compliant
- ✧ AEC-Q101 qualified
- ✧ Compliant to Halogen-free
- ✧ Suffix "-Q1" for AEC-Q101

### MAIN APPLICATIONS

- ✧ RS-232, RS-422 & RS-485
- ✧ Servers, notebook, and desktop
- ✧ Cellular handsets and accessories
- ✧ Control & monitoring systems
- ✧ Portable electronics
- ✧ Wireless bus protection
- ✧ Set-top box

### PROTECTION SOLUTION TO MEET

- ✧ IEC61000-4-2 (ESD)  $\pm 15kV$  (air),  $\pm 8kV$  (contact)
- ✧ IEC61000-4-4 (EFT) 40A (5/50ns)
- ✧ IEC61000-4-5 (Lightning) 18A (8/20 $\mu s$ )

### MECHANICAL CHARACTERISTICS

- ✧ SOT-23 package
- ✧ Molding compound flammability rating : UL 94V-0
- ✧ Lead finish : lead free
- ✧ Marking code: 5B2

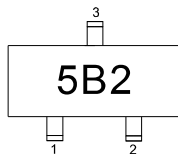

### Pin Configuration

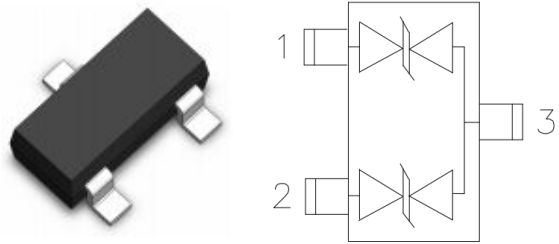

### ABSOLUTE MAXIMUM RATINGS ( $T_A=25^\circ\text{C}$ , RH=45%-75%, unless otherwise noted)

Parameter	Symbol	Value	Unit
Peak pulse power dissipation on 8/20 $\mu\text{s}$ waveform	$P_{PP}$	350	W
ESD per IEC 61000-4-2 (Air)	$V_{ESD}$	+/- 15	kV
ESD per IEC 61000-4-2 (Contact)		+/- 8	
Lead soldering temperature	$T_L$	260 (10 sec.)	$^\circ\text{C}$
Operating junction temperature range	$T_J$	-55 to +125	$^\circ\text{C}$
Storage temperature range	$T_{STG}$	-55 to +150	$^\circ\text{C}$

### ELECTRICAL CHARACTERISTICS ( $T_A=25^\circ\text{C}$ )

Parameter	Symbol	Conditions	Min	Typ	Max	Unit
Reverse working voltage	$V_{RWM}$				5.0	V
Reverse breakdown voltage	$V_{BR}$	$I_T = 1\text{mA}$	6.0			V
Reverse leakage current	$I_R$	$V_{RWM} = 5\text{V}$			1	$\mu\text{A}$
Clamping voltage	$V_C$	$I_{PP}^{(1)} = 1\text{A}$ , $t_p = 8/20\mu\text{s}$			9.8	V
		$I_{PP}^{(1)} = 18\text{A}$ , $t_p = 8/20\mu\text{s}$			16.7	V
Junction capacitance	$C_J^{(2)}$	$V_{RWM} = 0\text{V}$ , $f = 1\text{MHz}$		75		pF

① Surge waveform: 8/20 $\mu\text{s}$

②  $C_J$  measured @  $V_{RWM}=0\text{V}$ , 1MHz (pin 1 to pin3, pin 2 to pin3)

### RATINGS AND V-I CHARACTERISTICS CURVES ( $T_A=25^\circ\text{C}$ , unless otherwise noted)

**FIG.1: V- I curve characteristics (Bi-directional)**

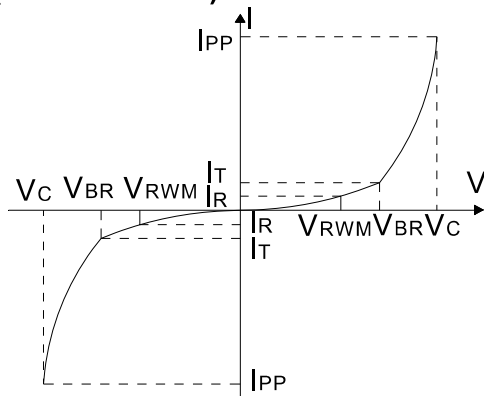

**FIG.2: Pulse waveform (8/20 $\mu\text{s}$ )**

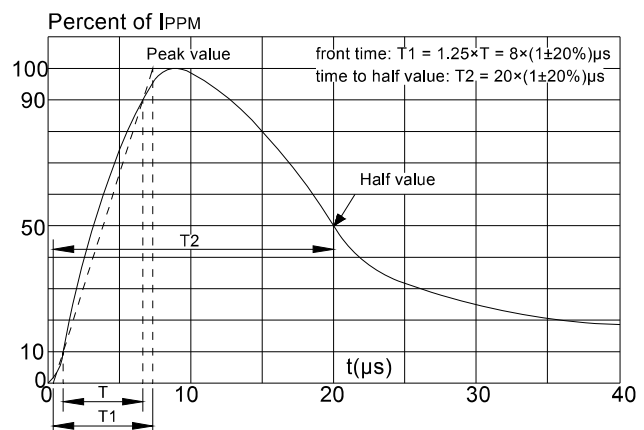

**FIG.3: Pulse derating curve**

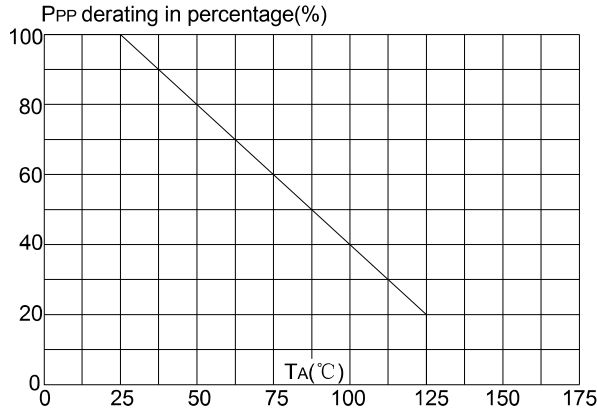

**FIG.4: ESD clamping (8KV contact)**

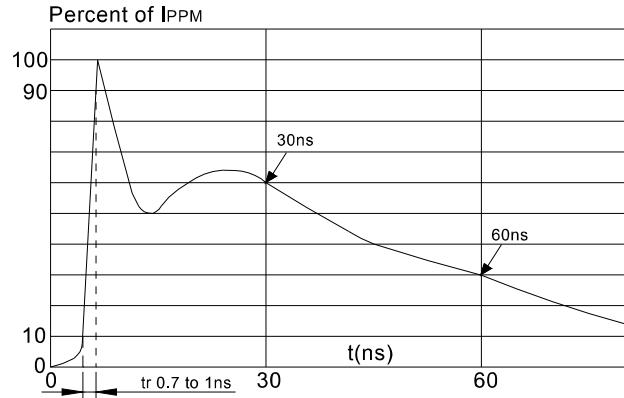

### PACKAGE MECHANICAL DATA

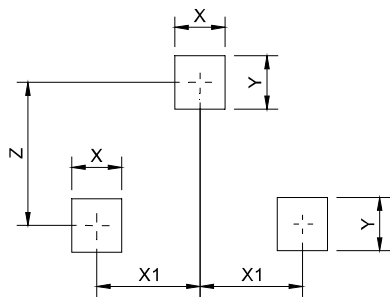
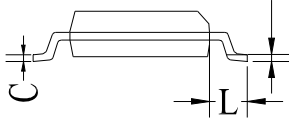
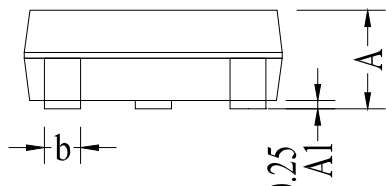
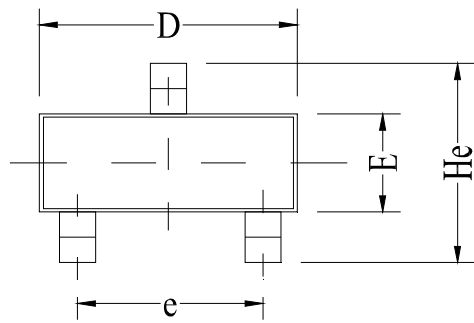

**Land Pattern**

Symbol	Millimeter		Inches	
	Min	Max	Min	Max
A	0.9	1.15	0.035	0.045
A1	0.00	0.10	0.000	0.004
b	0.25	0.325	0.01	0.013
C	0.22	0.25	0.009	0.01
D	2.8	3.0	0.11	0.118
e	1.8	1.9	0.071	0.075
E	1.2	1.4	0.047	0.055
L	0.30	0.50	0.012	0.02
He	2.25	2.55	0.089	0.1
X	0.8		0.0315	
X1	0.95		0.037	
Y	0.80		0.0315	
Z	2.02		0.0795	