

Features

- High current capacity in compact package $I_c = -1.5A$
- Epitaxial planar type
- Pb-free package is available
- Compliant to Halogen-free

Mechanical data

- Epoxy: UL94-V0 rated flame retardant
- Case : Molded plastic, SOT-23
- Terminals : Solder plated, solderable per MIL-STD-750, Method 2026
- Mounting Position : Any

Package outline

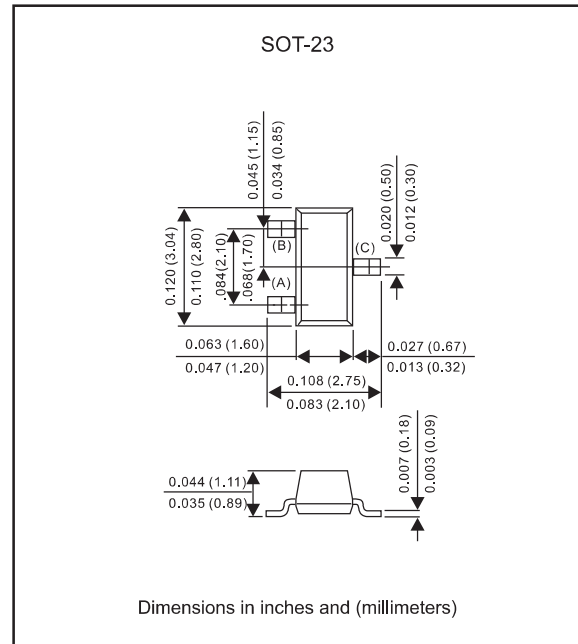

Maximum ratings (AT $T_A = 25^\circ C$ unless otherwise noted)

PARAMETER	Symbol	Value	UNIT
Collector-base voltage	V_{CBO}	-40	V
Collector-emitter voltage	V_{CEO}	-25	V
Emitter-base voltage	V_{EBO}	-5.0	V
Collector current-continuoun	I_c	- 1500	mAdc

Thermal characteristics

PARAMETER	Symbol	MIN.	TYP.	MAX.	UNIT
Total device dissipation FR-5 board (1)	$T_A = 25^\circ C$			225	mW
	Derate above $25^\circ C$			1.8	mW/ $^\circ C$
Thermal resistance	Junction to ambient			556	$^\circ C/W$
Total device dissipation alumina substrate(2)	$T_A = 25^\circ C$			300	mW
	Derate above $25^\circ C$			2.4	mW/ $^\circ C$
Thermal resistance	Junction to ambient			417	$^\circ C/W$
Operating junction temperature range	T_J	-55		+150	$^\circ C$
Storage temperature range	T_{STG}	-55		+150	$^\circ C$

1.FR-5 = 1.0 X 0.75 X 0.062 in.

2.Alumina = 0.4 X 0.3 X 0.024 in. 99.5% alumina.

Electrical characteristics (AT $T_A=25^\circ\text{C}$ unless otherwise noted)

Off characteristics

PARAMETER	CONDITIONS	Symbol	MIN.	TYP.	MAX.	UNIT
Collector-base breakdown voltage	$I_c = -100\mu\text{A}$	$V_{(BR)CBO}$	-40			V
Collector-emitter breakdown voltage	$I_c = -1.0\text{mA}$	$V_{(BR)CEO}$	-25			V
Emitter-base breakdown voltage	$I_e = -100\mu\text{A}$	$V_{(BR)EBO}$	-5.0			V
Collector cutoff current	$V_{CB} = -35\text{V}$	I_{CBO}			-150	nA
Emitter cutoff current	$V_{EB} = -4.0\text{V}$	I_{EBO}			-150	nA

On characteristics

PARAMETER	CONDITIONS	Symbol	MIN.	TYP.	MAX.	UNIT
DC current gain	$I_c = -100\text{mA}, V_{CE} = -1.0\text{V}$	h_{FE}^{*Note}	100		600	
Collector-emitter saturation voltage	$I_c = -800\text{mA}, I_b = -80\text{mA}$	$V_{CE(sat)}$			-0.5	V

Note	*	L	H	J
	h_{FE}		120~200	200~350

Rating and characteristic curves

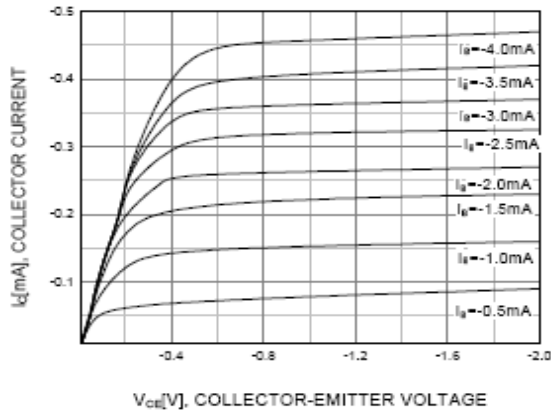

Figure 1. Static Characteristic

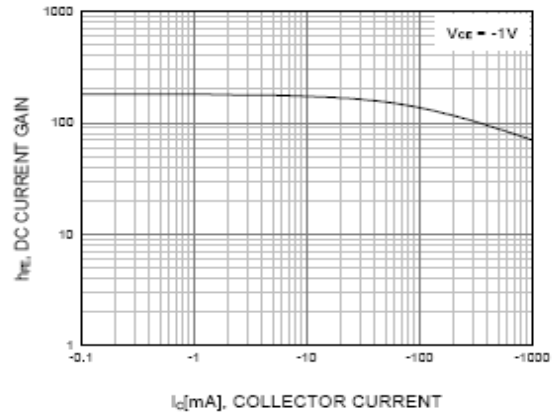

Figure 2. DC current Gain

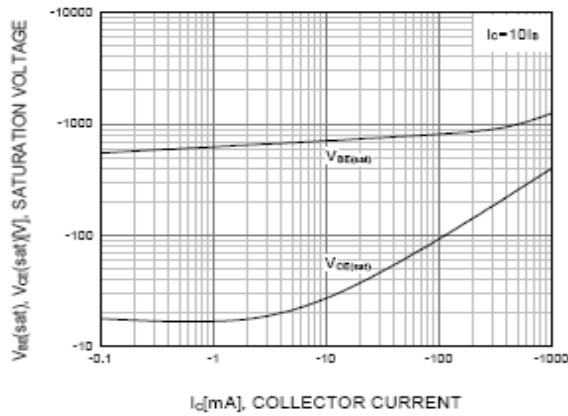

Figure 3. Base-Emitter Saturation Voltage
Collector-Emitter Saturation Voltage

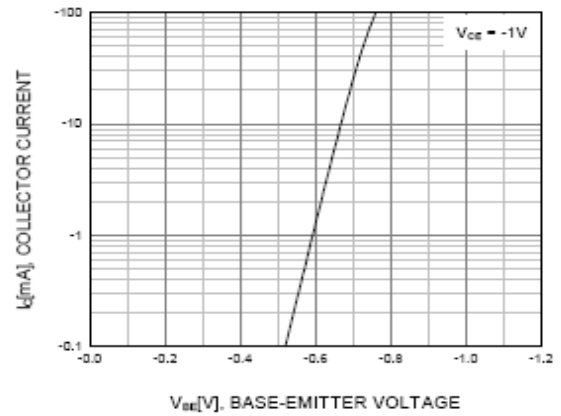

Figure 4. Base-Emitter On Voltage

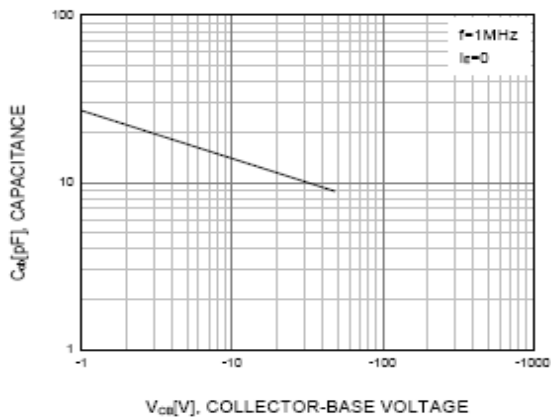

Figure 5. Collector Output Capacitance

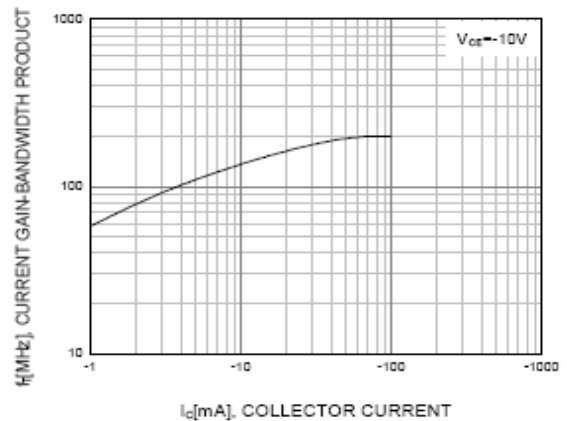
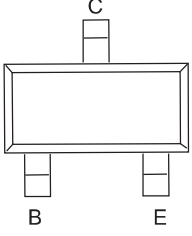
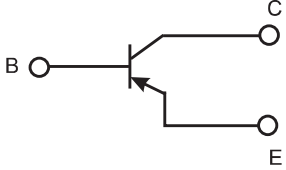

Figure 6. Current Gain Bandwidth Product

Pinning information

Pin	Simplified outline	Symbol
PinB Base PinC Collector PinE Emitter		

Marking

Type number	Marking code
SS8550	Y2

Suggested solder pad layout

SOT-23

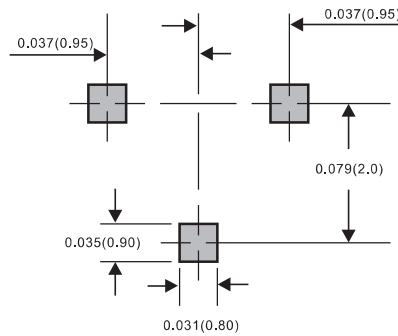

Dimensions in inches and (millimeters)