

### Package outline

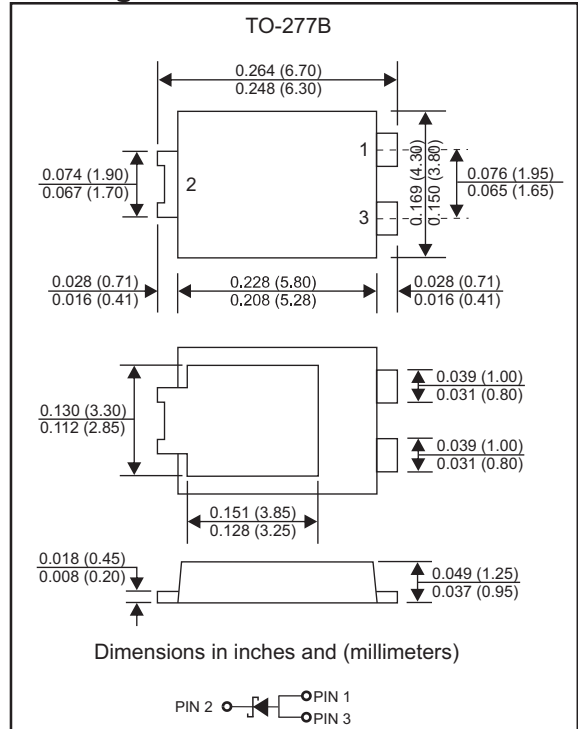

### Features

- Ultra Low Forward Voltage Drop .
- Very low profile-typical height of 1.10mm
- Low Power Losses,High Efficiency Operation
- Low Thermal Resistance Package.
- High Operating Junction Temperature.
- Compliant to Halogen-free
- Suffix "-Q1" for AEC-Q101

### Mechanical data

- Epoxy:UL94-V0 rated flame retardant
- Case : TO-277B , molded Plastic
- Terminals:Solderable per MIL-STD-750,Method 2026

### Maximum ratings (AT $T_A=25^\circ\text{C}$ unless otherwise noted)

Parameter	Symbol	SU15100-T-Q1	Unit
DC Blocking Voltage	$V_{DC}$	100	V
Working Peak Reverse Voltage	$V_{RWM}$		
Repetitive Peak Reverse Voltage	$V_{RRM}$		
RMS Reverse Voltage	$V_{RMS}$	70	V
Average Forward Rectified Current	$I_{F(AV)}$	15.0	A
Peak Forward Surge Current,8.3ms Half Sine-wave( $T_A=25^\circ\text{C}$ )	$I_{FSM}$	200	A
Operating junction temperature range	$T_J$	-55 to +150	$^\circ\text{C}$
Storage temperature range	$T_{STG}$	-55 to +150	$^\circ\text{C}$

### Electrical Characteristics (AT $T_A=25^\circ\text{C}$ unless otherwise noted)

Parameter	Test Conditions	Symbol	MIN.	TYP.	MAX.	Unit
Reverse Breakdown Voltage	$I_R=0.5\text{mA}, T_J=25^\circ\text{C}$	$V_B$	100	-	-	V
Forward voltage	$I_F=15\text{A}, T_J=25^\circ\text{C}$	$V_F$	-	0.68	0.7	V
Reverse current	$V_R=100\text{V}, T_J=25^\circ\text{C}$	$I_R$	-	0.15	0.3	mA
	$V_R=100\text{V}, T_J=125^\circ\text{C}$		-	10	20	

### Thermal Characteristics

Parameter	Symbol	SU15100-T-Q1	Unit
Typical thermal resistance junction to ambient (Note 1)	$R_{\theta JA}$	13	$^\circ\text{C/W}$
Typical thermal resistance junction to case (Note 1)	$R_{\theta JC}$	2	$^\circ\text{C/W}$

Note 1: Mounted on FR-4 PCB copper pad area. Cathode pad dimensions 4.95mm x 3.4mm.  
Anode pad dimensions 1.55mm x 5.0mm.

## Rating and characteristic curves

FIG. 1- DERATING CURVE OUTPUT RECTIFIED CURRENT

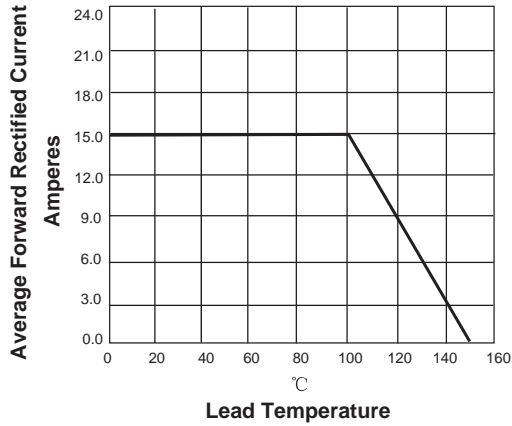

FIG. 2-MAXIMUM NON-REPETITIVE PEAK FORWARD SURGE CURRENT PERLEG

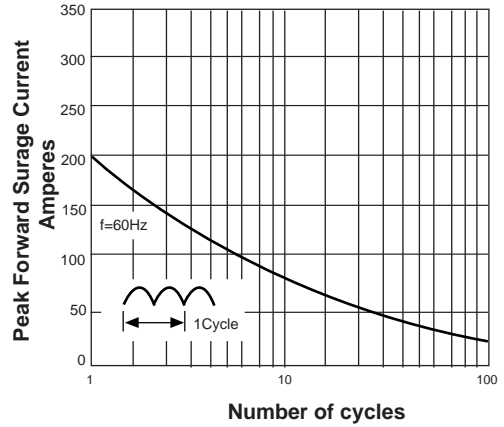

FIG. 3-TYPICAL FORWARD VOLTAGE CHARACTERISTICS

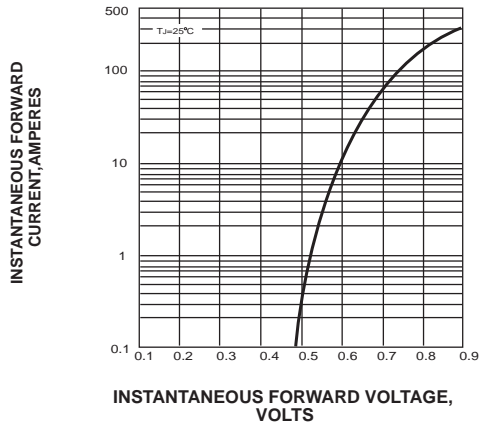
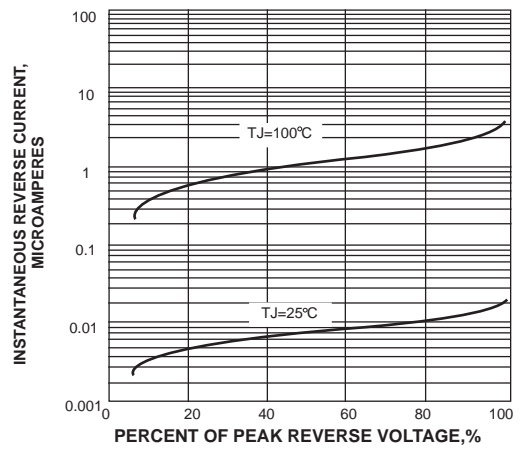

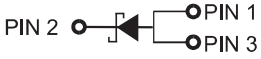

FIG. 4-TYPICAL REVERSE LEAKAGE CHARACTERISTICS



### Pinning information

Pin	Simplified outline	Symbol
Pin2 cathode Pin1 anode Pin3 anode		

### Marking

Type number	Marking code
SU15100-T-Q1	SU15100

### Suggested solder pad layout

TO-277B

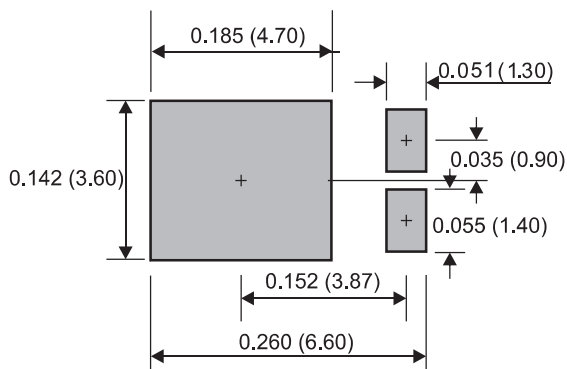

Dimensions in inches and (millimeters)